

SIEMENS

Industrial Controls

Detecting devices SIRIUS 3SE5/3SF1/3SE66/3SE67 position switches



Configuration Manual

| | |
|--|----------|
| <u>Introduction</u> | 1 |
| <u>Safety notes</u> | 2 |
| <u>General description</u> | 3 |
| <u>Position switches, safety switches, hinge switches and magnetically operated switches</u> | 4 |
| <u>Application examples</u> | 5 |
| <u>Appendix</u> | A |

Legal information

Warning notice system

This manual contains notices you have to observe in order to ensure your personal safety, as well as to prevent damage to property. The notices referring to your personal safety are highlighted in the manual by a safety alert symbol, notices referring only to property damage have no safety alert symbol. These notices shown below are graded according to the degree of danger.

| |
|--|
|  DANGER |
| indicates that death or severe personal injury will result if proper precautions are not taken. |
|  WARNING |
| indicates that death or severe personal injury may result if proper precautions are not taken. |
|  CAUTION |
| indicates that minor personal injury can result if proper precautions are not taken. |
| NOTICE |
| indicates that property damage can result if proper precautions are not taken. |

If more than one degree of danger is present, the warning notice representing the highest degree of danger will be used. A notice warning of injury to persons with a safety alert symbol may also include a warning relating to property damage.

Qualified Personnel

The product/system described in this documentation may be operated only by **personnel qualified** for the specific task in accordance with the relevant documentation, in particular its warning notices and safety instructions. Qualified personnel are those who, based on their training and experience, are capable of identifying risks and avoiding potential hazards when working with these products/systems.

Proper use of Siemens products

Note the following:

| |
|--|
|  WARNING |
| Siemens products may only be used for the applications described in the catalog and in the relevant technical documentation. If products and components from other manufacturers are used, these must be recommended or approved by Siemens. Proper transport, storage, installation, assembly, commissioning, operation and maintenance are required to ensure that the products operate safely and without any problems. The permissible ambient conditions must be complied with. The information in the relevant documentation must be observed. |

Trademarks

All names identified by ® are registered trademarks of Siemens AG. The remaining trademarks in this publication may be trademarks whose use by third parties for their own purposes could violate the rights of the owner.

Disclaimer of Liability

We have reviewed the contents of this publication to ensure consistency with the hardware and software described. Since variance cannot be precluded entirely, we cannot guarantee full consistency. However, the information in this publication is reviewed regularly and any necessary corrections are included in subsequent editions.

Table of contents

| | | |
|----------|---|-----------|
| 1 | Introduction | 9 |
| 1.1 | Purpose of this documentation | 9 |
| 1.2 | Target group | 9 |
| 1.3 | Required knowledge | 9 |
| 1.4 | History | 10 |
| 1.5 | Siemens Industry Online Support..... | 11 |
| 1.6 | Latest information | 13 |
| 1.7 | Siemens Industry Online Support app..... | 14 |
| 1.8 | Technical Assistance | 14 |
| 1.9 | Technical data in Siemens Industry Online Support..... | 15 |
| 1.10 | Certificates | 15 |
| 2 | Safety notes | 17 |
| 2.1 | Security information | 17 |
| 2.2 | Recycling and disposal | 17 |
| 3 | General description | 19 |
| 3.1 | Application areas | 19 |
| 3.2 | Failure rates | 19 |
| 3.3 | Overview of position switches in open-type and compact design | 21 |
| 3.4 | Overview of mechanical position switches | 24 |
| 3.5 | Overview of safety switches | 26 |
| 3.6 | Overview of 3SE22 safety switches..... | 27 |
| 3.7 | Overview of mechanical safety switches for AS-Interface..... | 28 |
| 3.8 | Overview of hinge switches | 29 |
| 3.9 | Overview of magnetically operated switches..... | 31 |
| 3.9.1 | 3SE66/3SE67 non-contact magnetically operated safety switches | 31 |
| 3.9.2 | Monitoring unit | 35 |
| 3.10 | Features of position switches | 35 |
| 3.10.1 | Basic function..... | 35 |
| 3.10.2 | Electromechanical sensors..... | 36 |
| 3.10.3 | Contact element variance | 37 |
| 3.10.4 | Article No. scheme..... | 40 |
| 3.10.5 | Selection of 3SE position switches | 40 |
| 3.10.6 | Online configuration | 41 |
| 3.10.6.1 | Use of the online configurator | 41 |

| | | |
|----------|---|-----------|
| 3.10.6.2 | Application of the online configurator..... | 42 |
| 4 | Position switches, safety switches, hinge switches and magnetically operated switches..... | 47 |
| 4.1 | Position switches in open-type design..... | 48 |
| 4.1.1 | Technical data for position switches in open-type design | 50 |
| 4.1.1.1 | Technical data in Siemens Industry Online Support..... | 50 |
| 4.1.2 | Dimension drawings and operating travel diagrams for position switches in open-type design..... | 51 |
| 4.2 | Position switches in compact design | 53 |
| 4.2.1 | Actuator heads for position switches in compact design with molded cable | 55 |
| 4.2.2 | Mounting the actuator head | 58 |
| 4.2.3 | Technical data for position switches in compact design | 59 |
| 4.2.3.1 | Technical data in Siemens Industry Online Support..... | 59 |
| 4.2.4 | Dimension drawings and operating travel diagrams for position switches in compact design..... | 59 |
| 4.3 | Mechanical position switches..... | 63 |
| 4.3.1 | Plastic enclosure | 63 |
| 4.3.2 | Metal enclosure..... | 65 |
| 4.3.3 | Complete units | 66 |
| 4.3.4 | Optional LED displays..... | 68 |
| 4.3.5 | Enclosure | 69 |
| 4.3.6 | Actuators and their actuation | 71 |
| 4.3.6.1 | Plain plunger/rounded plunger..... | 72 |
| 4.3.6.2 | Roller plunger..... | 73 |
| 4.3.6.3 | Roller plunger for central fixing | 74 |
| 4.3.6.4 | Roller lever | 75 |
| 4.3.6.5 | Angular roller lever..... | 76 |
| 4.3.6.6 | Spring rod..... | 77 |
| 4.3.6.7 | Part-turn actuators with lever | 78 |
| 4.3.6.8 | Twist lever..... | 80 |
| 4.3.6.9 | Adjustable-length twist lever with oblong hole | 82 |
| 4.3.6.10 | Adjustable-length twist lever with pre-drilled holes | 83 |
| 4.3.6.11 | Rod lever..... | 84 |
| 4.3.6.12 | Fork lever | 85 |
| 4.3.7 | Combinations | 86 |
| 4.3.8 | Connection..... | 87 |
| 4.3.8.1 | Contact blocks..... | 87 |
| 4.3.8.2 | Quick-connect system..... | 89 |
| 4.3.8.3 | Plug connection..... | 89 |
| 4.3.8.4 | Device connector: pin assignment..... | 90 |
| 4.3.9 | Notes on installation..... | 91 |
| 4.3.9.1 | Installation instructions for twist levers | 91 |
| 4.3.9.2 | Changing the actuator head..... | 92 |
| 4.3.10 | Technical data for mechanical position switches..... | 94 |
| 4.3.10.1 | Technical data in Siemens Industry Online Support..... | 94 |
| 4.3.11 | Dimension drawings and operating travel diagrams for mechanical position switches..... | 95 |
| 4.3.12 | Accessories and spare parts..... | 130 |
| 4.3.12.1 | Quick-release device for enclosure width 40 mm | 130 |
| 4.3.12.2 | Plug-in connections for connecting thread M20 x 1.5..... | 131 |
| 4.3.12.3 | Cable gland..... | 133 |
| 4.3.12.4 | Adapters..... | 133 |

| | | |
|----------|---|-----|
| 4.3.12.5 | Protective cover made of plastic..... | 133 |
| 4.4 | Mechanical safety switches | 134 |
| 4.4.1 | Application examples | 134 |
| 4.4.2 | Actuator head and actuators..... | 134 |
| 4.4.3 | Operating travel diagrams for mechanical safety switches | 135 |
| 4.4.4 | Combinations | 136 |
| 4.4.5 | Actuator accessories..... | 137 |
| 4.5 | Mechanical safety switches with separate actuation | 147 |
| 4.5.1 | 3SE22 safety switches with separate actuation | 147 |
| 4.5.2 | Mounting instructions for safety switches with separate actuation | 148 |
| 4.5.3 | Technical data for mechanical safety switches with separate actuation | 149 |
| 4.5.3.1 | Technical data in Siemens Industry Online Support..... | 149 |
| 4.5.4 | Dimension drawings and operating travel diagrams..... | 150 |
| 4.5.4.1 | 3SE5 mechanical safety switches with separate actuation | 150 |
| 4.5.4.2 | 3SE22 safety switches with separate actuation | 151 |
| 4.5.4.3 | Operating travel diagrams of position switches with separate actuation..... | 154 |
| 4.5.5 | Accessories for 3SE22 safety switches | 155 |
| 4.6 | Mechanical safety switches with tumbler..... | 155 |
| 4.6.1 | Interlock types..... | 158 |
| 4.6.2 | Typical circuit diagram with evaluation unit in accordance with SIL2..... | 165 |
| 4.6.3 | Installing and securing the actuator head..... | 167 |
| 4.6.4 | Notes on installation..... | 168 |
| 4.6.5 | Technical data for mechanical safety switches with tumbler..... | 174 |
| 4.6.5.1 | Technical data in Siemens Industry Online Support..... | 174 |
| 4.6.6 | Maximum achievable safety category..... | 174 |
| 4.6.7 | Dimension drawings for mechanical safety switches with tumbler..... | 175 |
| 4.7 | Hinge switches..... | 177 |
| 4.7.1 | Notes on installation..... | 179 |
| 4.7.1.1 | Mounting 3SE5 hinge switches..... | 179 |
| 4.7.1.2 | Mounting 3SE2283 hinge switches..... | 179 |
| 4.7.2 | Technical data for hinge switches..... | 181 |
| 4.7.2.1 | Technical data in Siemens Industry Online Support..... | 181 |
| 4.7.3 | Dimension drawings and operating travel diagrams..... | 181 |
| 4.8 | Magnetically operated switches..... | 185 |
| 4.8.1 | 3SE66/3SE67 non-contact magnetically operated safety switches | 185 |
| 4.8.1.1 | Mounting position for 3SE66 magnetically operated switches | 186 |
| 4.8.1.2 | 3SE660 pin assignments | 188 |
| 4.8.1.3 | Notes on installation..... | 189 |
| 4.8.1.4 | Technical data for 3SE660 magnetically-operated switches..... | 190 |
| 4.8.1.5 | Dimension drawings for magnetically operated switches and contact blocks..... | 191 |
| 4.8.1.6 | Dimension drawings of switching magnets..... | 193 |
| 4.8.1.7 | Dimension drawings of spacers..... | 194 |
| 4.8.1.8 | Example circuits..... | 195 |
| 4.8.2 | 3SE661 / 3SE662 non-contact magnetically operated safety switches | 196 |
| 4.8.2.1 | Mounting position..... | 197 |
| 4.8.2.2 | Pin assignments..... | 198 |
| 4.8.2.3 | Technical data for 3SE661 / 3SE662 magnetically-operated switches | 199 |
| 4.8.2.4 | Dimension drawings..... | 200 |
| 4.8.3 | Notes on installation..... | 203 |
| 4.8.4 | Magnetically operated switch - monitoring unit combination | 206 |

| | | |
|-----------|---|------------|
| 4.9 | 3SF1 mechanical safety switches for AS-Interface | 208 |
| 4.9.1 | Overview | 209 |
| 4.9.2 | Modular system..... | 209 |
| 4.9.3 | LED display | 209 |
| 4.9.4 | Plug connection..... | 210 |
| 4.9.5 | Mounting | 210 |
| 4.9.6 | Technical data for safety switches for AS-Interface..... | 210 |
| 4.9.6.1 | Technical data in Siemens Industry Online Support..... | 210 |
| 4.9.7 | Dimension drawings for safety switches for AS-Interface | 211 |
| 4.9.8 | Safety switches for AS-Interface with separate actuation | 212 |
| 4.9.8.1 | Overview | 212 |
| 4.9.8.2 | Actuators | 212 |
| 4.9.8.3 | LED display | 213 |
| 4.9.8.4 | Connection with separate actuation..... | 213 |
| 4.9.8.5 | Technical data for safety switches for AS-Interface with separate actuation with tumbler | 213 |
| 4.9.8.6 | Dimension drawings for safety switches for AS-Interface with separate actuation | 214 |
| 4.9.9 | Pin assignment..... | 215 |
| 4.9.10 | Safety switches for AS-Interface with separate actuation with tumbler | 215 |
| 4.9.10.1 | Overview | 215 |
| 4.9.10.2 | Actuation | 216 |
| 4.9.10.3 | 3SF13..-...-1BA1 | 216 |
| 4.9.10.4 | 3SF13..-...-1BA4 | 217 |
| 4.9.10.5 | Direct connection of safety monitor, Category 3/SIL 2/PL d | 218 |
| 4.9.10.6 | Interlock types | 219 |
| 4.9.10.7 | LED display | 220 |
| 4.9.10.8 | Connection with tumbler | 221 |
| 4.9.10.9 | Technical data for safety switches for AS-Interface with tumbler | 222 |
| 4.9.10.10 | Maximum achievable safety category..... | 222 |
| 4.9.10.11 | Dimension drawings for safety switches for AS-Interface with tumbler | 223 |
| 4.10 | Safety relays | 224 |
| 4.10.1 | Overview of safety relays..... | 224 |
| 4.10.2 | 3SE6806-2CD00 safety relay | 225 |
| 4.10.3 | Achievable safety level in combination with safety relays | 226 |
| 4.10.4 | Terminal assignments..... | 228 |
| 4.10.5 | LED display, 3SE6806 safety relay..... | 229 |
| 4.10.6 | Technical data for 3SE6806 safety relay | 229 |
| 4.10.6.1 | Technical data in Siemens Industry Online Support..... | 229 |
| 4.10.7 | Typical circuit diagram with safety relay function..... | 230 |
| 5 | Application examples | 233 |
| 5.1 | Installation instructions..... | 233 |
| 5.1.1 | Protection against approach and overtravel | 233 |
| 5.1.2 | Cable entry..... | 236 |
| 5.1.3 | Securing against change of position (fixing) | 238 |
| 5.1.4 | Quick-release device for enclosure width 40 mm | 239 |
| 5.2 | Application suggestion | 240 |
| 5.2.1 | Positive opening position switches | 241 |
| 5.3 | Application example - Rounded plunger | 242 |
| 5.4 | Application example - Roller plunger | 243 |

| | | |
|----------|--|------------|
| 5.5 | Application example - Roller lever | 244 |
| 5.6 | Application example - Angular roller lever | 245 |
| 5.7 | Application example - Spring rod..... | 246 |
| 5.8 | Application example - Twist lever | 247 |
| 5.9 | Application example - Adjustable-height twist lever | 248 |
| 5.10 | Application example - Adjustable-height rod lever | 250 |
| 5.11 | Application example - Fork lever | 251 |
| 5.12 | Application example - Hinge switch..... | 252 |
| 5.13 | Application example of safety switch without tumbler | 253 |
| 5.14 | Application example of safety switch with tumbler | 255 |
| 5.15 | Application example of a magnetically-operated switch | 258 |
| 5.16 | Special environmental requirements | 262 |
| 5.16.1 | Icing | 262 |
| 5.16.2 | UV radiation | 262 |
| 5.16.3 | Humidity and wet conditions | 262 |
| 5.16.3.1 | Condensation..... | 262 |
| 5.16.3.2 | Water jet..... | 264 |
| 5.16.3.3 | Immersing | 265 |
| 5.16.4 | Dust, dirt, oil | 265 |
| 5.16.5 | Cleaning agent, chemical environment..... | 265 |
| 5.16.6 | Extreme temperatures | 266 |
| 5.17 | Protecting against change in position | 266 |
| A | Appendix..... | 267 |
| A.1 | Standards and approvals..... | 267 |
| A.1.1 | Standards for mechanical position switches..... | 267 |
| A.1.2 | General information regarding dimensions and characteristic values for position switches | 268 |
| A.2 | Description of the degrees of protection | 269 |
| | Index..... | 271 |

Introduction

1.1 Purpose of this documentation

This manual describes the many possible uses of SIRIUS detection devices for monitoring motion sequences or protective devices.

General information will be provided about the principal of operation, selection, and installation of mechanical position switches and safety switches to enable their reliable operation.

1.2 Target group

This documentation contains information for the following target groups:

- Decision makers
- Technologists
- Project planning engineers
- Commissioning engineers

1.3 Required knowledge

Zum Verständnis dieser Dokumentation sind allgemeine Grundkenntnisse auf folgenden Gebieten erforderlich:

- Low-voltage controls and distribution
- Digital circuit logic
- Automation technology
- AS-Interface
- Safety technology

1.4 History

The following editions of this documentation have been published to date. The changes apply in comparison to the previous version:

| Edition | Comment/change |
|----------------|---|
| 07/2010 | First edition |
| 05/2012 | Product range expanded; technical data and operating travel diagrams updated |
| 11 / 2015 | Section on ATEX switches no longer part of the manual. Magnetically operated switches added to the product range. The very latest technical data (Page 15) can now be accessed on the Internet. |
| 02/2017 | Expansion of actuator product range for mechanical safety switches |
| 06/2018 | New installation notes in Chapter Magnetically-operated switches |

1.5 Siemens Industry Online Support

Information and service

At Siemens Industry Online Support you can obtain up-to-date information from our global support database quickly and simply. To accompany our products and systems, we offer a wealth of information and services that provide support in every phase of the lifecycle of your machine or plant – from planning and implementation and commissioning, right through to maintenance and modernization:

- Product support
- Application examples
- Services
- Forum
- mySupport

Link: Siemens Industry Online Support (<https://support.industry.siemens.com/cs/de/en>)

Product support

Here you will find all the information and comprehensive know-how for your product:

- **FAQs**
Our replies to frequently asked questions.
- **Manuals/operating instructions**
Read online or download, available as PDF or individually configurable.
- **Certificates**
Clearly sorted according to approving authority, type and country.
- **Characteristics**
For support in planning and configuring your system.
- **Product announcements**
The latest information and news concerning our products.
- **Downloads**
Here you will find updates, service packs, HSPs and much more for your product.
- **Application examples**
Function blocks, background and system descriptions, performance statements, demonstration systems, and application examples, clearly explained and represented.
- **Technical data**
Technical product data for support in planning and implementing your project.

Link: Product support (<https://support.industry.siemens.com/cs/ww/en/ps>)

mySupport

With "mySupport", your personal work area, you get the very best out of your Industry Online Support experience. Everything enables you to find the right information - every time.

The following functions are now available:

- **Personal messages**
Your personal mailbox for exchanging information and managing your contacts
- **Requests**
Use our online form for specific solution suggestions, or send your technical request direct to a specialist in Technical Support
- **Notifications**
Make sure you always have the latest information - individually tailored to your needs
- **Filter**
Simple management and re-use of your filter settings from Product Support and the Technical Forum
- **Favorites / Tags**
Create your own "knowledge base" by assigning "Favorites" and "Tags" to documents – simple and efficient
- **Entries last viewed**
Clear history of the entries you have most recently viewed
- **Documentation**
Configure and compile individual documentation concepts from different manuals – quickly and without complications
- **Personal data**
Change personal data and contact information here
- **CAX data**
Simple access to thousands of items of CAX data such as 3D models, 2D dimension drawings, EPLAN macros and much more

1.6 Latest information

Selection data and ordering data

You can find additional information about command and signaling devices on the Internet in the Industry Mall.

Here, you have access to

- Catalogs/brochures (<http://www.siemens.com/industrial-controls/catalogs>)
- Online configuration (<http://www.siemens.com/sirius/configurators>)

See also

Internet: (<http://www.siemens.com/industrial-controls/technical-assistance>)

E-mail: (<mailto:technical-assistance@siemens.com>)

1.7 Siemens Industry Online Support app

Siemens Industry Online Support app

You can use the Siemens Industry Online Support app to access all the device-specific information available on the Siemens Industry Online Support portal for a particular article number, including operating instructions, manuals, datasheets, FAQs etc.

The Siemens Industry Online Support app is available for iOS, Android or Windows Phone devices. You can download the app from the following links:



Link for Android



Link for iOS



Link for Windows Phone

1.8 Technical Assistance

Using the support request form in Online Support you can send your query directly to our Technical Assistance. After describing your query in a few guided steps, you will immediately be provided with possible suggestions for solving the problem.

| | |
|------------------------------|--|
| Technical Assistance: | Telephone: +49 (0) 911-895-5900 (8:00 a.m. - 5:00 p.m. CET) Fax: +49 (0) 911-895-5907 E-mail (mailto:technical-assistance@siemens.com) Internet (http://www.siemens.com/sirius/technical-assistance) |
|------------------------------|--|

1.9 Technical data in Siemens Industry Online Support

Technical data sheet

You can also find the technical data of the product at Siemens Industry Online Support (<https://support.industry.siemens.com/cs/ww/en/ps/>).

1. Enter the full article number of the desired device in the "Product" field, and confirm with the Enter key.
2. Click the "Technical data link.

The screenshot shows the search interface with the following elements:

- Product tree:** A dropdown menu set to "All" and a search bar labeled "Enter keyword...".
- Product field:** Contains the article number "3RV2131-4BA10" with a search icon and a clear button.
- Entry type:** A dropdown menu set to "Technical data (1)" with a clear button.
- Date:** Fields for "From" and "To" with a search icon.
- Search product:** A button to execute the search.
- Results:** A list of search results for "3RV2131-4BA10". The first result is highlighted, showing a description: "CIRCUIT BREAKER, SCREW TYPE, 20 A, CIRCUIT BREAKER SIZE S2, FOR MOTOR PROTECTION, CLASS 10, A-RELEASE 14, 30A, N-RELEASE 20A, SCREW TERMINAL, STANDARD BREAKING CAPACITY". Below the description are navigation links: "> Product details", "> Technical data" (highlighted with a red box), and "> CAx data".

1.10 Certificates

You can find all certificates for the product in Siemens Industry Online Support (<https://support.industry.siemens.com/cs/ww/en/ps/>).

1. Make a selection in the "Document type" > "Certificate" field.
2. Enter the full article number of the desired device in the "Product" field, and confirm with the Enter key.
3. All valid certificates for the chosen device are displayed in the bottom area of the page.

The screenshot shows the search interface with the following elements:

- Product tree:** A dropdown menu set to "All" and a search bar labeled "Enter search term...".
- Product field:** An empty search box with a search icon and a clear button.
- Entry type:** A dropdown menu set to "Certificate" with a clear button.
- Date:** Fields for "From" and "To" with a search icon.
- Search product:** A button to execute the search.

Safety notes

2.1 Security information

Siemens provides products and solutions with industrial security functions that support the secure operation of plants, systems, machines, and networks.

In order to protect plants, systems, machines and networks against cyber threats, it is necessary to implement – and continuously maintain – a holistic, state-of-the-art industrial security concept. Siemens' products and solutions only form one element of such a concept.

Customer is responsible to prevent unauthorized access to its plants, systems, machines and networks. Systems, machines and components should only be connected to the enterprise network or the internet if and to the extent necessary and with appropriate security measures (e.g. use of firewalls and network segmentation) in place.

Additionally, Siemens' guidance on appropriate security measures should be taken into account. You can find more information about industrial security by visiting:
<https://www.siemens.com/industrialsecurity>.

Siemens' products and solutions undergo continuous development to make them more secure. Siemens strongly recommends you apply product updates as soon as available and always use the latest product versions. Use of product versions that are no longer supported, and failure to apply latest updates may increase customer's exposure to cyber threats.

To stay informed about product updates, subscribe to the Siemens Industrial Security RSS Feed under
<https://www.siemens.com/industrialsecurity>.

2.2 Recycling and disposal

For environmentally friendly recycling and disposal of your old device, please contact a company certified for the disposal of old electrical and electronic devices and dispose of the device in accordance with the regulations in your country.

See also

Product return (<https://support.industry.siemens.com/cs/ww/en/view/109479891>)

Important note

The products described here were developed to perform safety-oriented functions as part of an overall installation or machine. A complete safety-oriented system generally features sensors, evaluation units, signaling units, and reliable shutdown concepts. It is the responsibility of the manufacturer to ensure that a system or machine is functioning properly as a whole. Siemens AG, its regional offices, and associated companies (hereinafter referred to as "Siemens") cannot guarantee all the properties of an overall installation or machine that has not been designed by Siemens. Nor can Siemens assume liability for recommendations that appear or are implied in the following description. No new guarantee, warranty, or liability claims beyond the scope of the Siemens general terms of supply are to be derived or inferred from the following description.

| |
|--|
|  DANGER |
| Hazardous voltage. Will cause death or serious injury. Electric shock. |
| Non-metallic enclosures do not provide grounding between conduit unions. Proper grounding between conduit unions must be established by using grounding bushings and jumper wires. |

| |
|---|
|  WARNING |
| Possible inaccurate signal. Personal injury or property damage can occur. |
| If the original actuator is not used, this may result in a defect on the module and the switch may no longer be able to lock or unlock. |
| Only use the designated actuator for the appropriate safety switch. |

| |
|--|
| NOTICE |
| The functionality of the switch cannot be ensured in the event of incorrect installation. |
| Incorrect installation will destroy the actuator head. |
| Install the position switch and actuator in such a way that the actuator can move into the actuator head without large lateral forces. Do not use position switches as an endstop. |

General description

3.1 Application areas

Mechanical position switches are used to detect (end) positions of moving machine and plant parts. Mechanical safety switches are used to protect personnel and machinery in manufacturing and processing lines.

The following are typical application areas for position switches:

- Protective devices
- Manufacturing and assembly lines
- Packaging systems and luggage sorting systems
- Elevators and conveyor systems
- Automatically controlled machines and robots

3.2 Failure rates

Using the B10 value, the failure rate of a position switch is calculated according to the following formula:

$$\lambda = [0.1 \times C / B10]$$

$$\lambda_D = [0.1 \times C / B10_d]$$

$$PFH_D = \lambda_D \times 1 \text{ h}$$

λ = Total failure rate of a position switch

λ_D = Failure rate of dangerous failures

C = Operating cycle per hour

$B10_d$ = B10 / Proportion of dangerous failures

SN 31920 standard

The B10 value for devices subject to wear is expressed in the number of switching cycles. This is the number of switching cycles at which during a lifetime test, 10% of the test objects have failed (or: number of operating cycles after which 10% of the devices have failed).

Note

Refer to the relevant data sheet (see Technical data in Siemens Industry Online Support (Page 15)) for the number of operating cycles.

Calculation example

A protective door is monitored by a position switch with a separate actuator. The protective door is opened 4 times an hour.

The total failure rate of the position switch is:



$$\lambda = 0.1 \times C / B10 \text{ [failures / h]} \quad \lambda = 0.1 \times 4 / 1000000 = 4 \times 10^{-7} \text{ [failures / h]}$$

The hazardous failure rate is calculated as:

$$\lambda_D = 20 \% \text{ of } \lambda = 0.2 \times 4 \times 10^{-7} \text{ [failures / h]}$$

$$\lambda_D = 8 \times 10^{-8} \text{ [failures / h]}$$

3.3 Overview of position switches in open-type and compact design

| Position switch | Open-type design | Compact design with connector | | Compact design with molded cable | |
|--|--|--|------------------------|---|------------------------|
| | 3SE5250 | 3SE5413--1EB1 | 3SE5423--1EB1 | 3SE5413--1EA. | 3SE5423--1EA. |
| |  |  | |  | |
| Enclosure | | | | | |
| Plastic | ✓ | — | | | |
| Metal | — | ✓ | | | |
| Dimensions (W x H x D) in mm | | | | | |
| | 30 x 48.5 x 20 | 30 x 50 x 16 | 40 x 50 x 16 | 30 x 50 x 16 | 40 x 50 x 16 |
| Degree of protection | IP10 or IP20 | IP67 | | | |
| Standards | | | | | |
| | IEC 60947-5-1 | | | | |
| Mounting and operating points according to standard | EN 50047 | EN 50047 | EN 50041 | EN 50047 | EN 50041 |
| Contact blocks | | | | | |
| 2 slow-action contacts | 1 NO + 1 NC | — | | | |
| 2 snap-action contacts | 1 NO + 1 NC | 1 NO + 1 NC | | | |
| 2 snap-action contacts, short stroke | 1 NO + 1 NC | — | | | |
| 2 snap-action contacts with 2 x 2 mm contact spacing | 1 NO + 1 NC | — | | | |
| 3 slow-action contacts | 2 NO + 1 NC 1 NO + 2 NC | — | | | |
| 3 slow-action contacts with make-before-break | 1 NO + 2 NC | — | | | |
| 3 snap-action contacts | 1 NO + 2 NC | — | | | |
| Technical data | | | | | |
| Actuating speed v | 0.1 mm/s to 1.5 m/s (snap-action contact) 0.4 mm/s to 1.5 m/s (slow-action contact) | 0.05 mm/s to 2 m/s | | | |
| Ambient temperature | -25 °C to +85 °C | | | | |

General description

3.3 Overview of position switches in open-type and compact design

| Position switch | Open-type design | Compact design with connector | | Compact design with molded cable | |
|----------------------|------------------|-------------------------------|------------------------|----------------------------------|------------------------|
| | 3SE5250 | 3SE5413--1EB1 | 3SE5423--1EB1 | 3SE5413--1EA. | 3SE5423--1EA. |
| Connections | | | | | |
| M12 connector, 5-pin | — | | ✓ | | — |
| Molded cable, 5-pin | — | | — | | ✓ |
| Actuator | | | | | |
| Rounded plunger | ✓ | | | ✓ | |
| Roller plunger | — | | | ✓ | |
| Twist lever | — | | | ✓ | |







✓ Available for delivery

— Not available

3.3 Overview of position switches in open-type and compact design

| 3SE54... complete units in compact design | Enclosure width mm |
|--|---------------------------|
| • 2 snap-action contacts 1 NO + 1 NC | |
| • Degree of protection IP67 | |
| • with connecting cable or M12 plug connector | |
| Rounded plunger | |
| • Standard mounting | |
| - with 2 m cable 5 x 0.75 mm ² | 30 40 |
| - with 5 m cable 5 x 0.75 mm ² | 30 |
| - with M12 plug connector | 30 40 |
| • with M12x1 central fixing | |
| - with 2 m cable 5 x 0.75 mm ² | 30 40 |
| • with external seal | |
| - with 2 m cable 5 x 0.75 mm ² | 30 40 |
| Roller plunger | |
| • Standard mounting | |
| - with 2 m cable 5 x 0.75 mm ² | 30 40 |
| - with 5 m cable 5 x 0.75 mm ² | 30 |
| - with M12 plug connector | 30 40 |
| • with M12 x 1 central fixing | |
| - with 2 m cable 5 x 0.75 mm ² | 30 40 |
| • Actuator head rotated 90° | |
| - with 2 m cable 5 x 0.75 mm ² | 30 40 |
| Twist lever | |
| • Standard mounting | |
| - with 2 m cable 5 x 0.75 mm ² | 30 40 |
| - with 5 m cable 5 x 0.75 mm ² | 30 |
| - with M12 plug connector | 30 40 |

3.4 Overview of mechanical position switches

| | Mechanical position switches | | | | | | XL enclosure |
|--|---|---|---|---|--|---|---|
| | 3SE523. | 3SE521. | 3SE524. | 3SE511. | 3SE513. | 3SE512. | 3SE516. |
| |  |  |  |  |  |  |  |
| Enclosure | | | | | | | |
| Plastic | ✓ | — | ✓ | — | ✓ | — | — |
| Metal | — | ✓ | — | ✓ | — | ✓ | ✓ |
| Dimensions (W x H x D) in mm | | | | | | | |
| | 31 x 68 x 33 | | 50 x 53 x 33 | 40 x 78 x 38 | | 56 x 78 x 38 | 56 x 100 x 27 |
| Degree of protection | IP65 | IP66/67 | IP66/67 | IP66/67 | | IP66/67 | IP66/67 |
| Standards | IEC 60947-5-1 | | | | | | |
| Mounting and operating points according to standard | EN 50047 | | EN 50047 | EN 50041 | | EN 50041 | EN 50041 |
| Contact blocks | 1 | | | 1 | | | 2 |
| Slow-action contacts | 1 NO + 1 NC | | | 1 NO + 1 NC | | | 2x (1 NO + 1 NC) |
| Snap-action contacts | 1 NO + 1 NC | | | 1 NO + 1 NC | | | 2x (1 NO + 1 NC) |
| Snap-action contacts, short-stroke | 1 NO + 1 NC | | | 1 NO + 1 NC | | | — |
| Snap-action contacts with 2 x 2 mm operating distance | 1 NO + 1 NC | | | 1 NO + 1 NC | | | — |
| Slow-action contacts | 1 NO + 2 NC 2 NO + 1 NC | | | 1 NO + 2 NC 2 NO + 1 NC | | | — |
| Snap-action contacts | 1 NO + 2 NC | | | 1 NO + 2 NC | | | — |
| Slow-action contacts with make-before-break | 1 NO + 2 NC | | | 1 NO + 2 NC | | | 2x (1 NO + 2 NC) |
| Slow-action contacts with make-before-break and slow-action contacts | — | | | — | | | 1x (1 NO + 2 NC) 1x (1 NO + 1 NC) |
| LED display | ✓ | | | ✓ | | | — |
| Increased anti-corrosion protection | ✓ | | | ✓ | | | ✓ |

✓ Available for delivery

— Not available

| | Mechanical position switches | | | | | | XL enclosure | |
|---|------------------------------|---------|-----------------|---------|-----------------|---------|-----------------|-----------------|
| | 3SE523. | 3SE521. | 3SE524. | 3SE511. | 3SE513. | 3SE512. | 3SE516. | |
| Connections | | | | | | | | |
| Cable entry | 1 x (M20 x 1.5) | | 2 x (M20 x 1.5) | | 1 x (M20 x 1.5) | | 3 x (M20 x 1.5) | 3 x (M20 x 1.5) |
| M12 connector, 4-, 5-, or 8-pin | ✓ | | ✓ | | ✓ | | ✓ | — |
| Connector, 6-pin + PE | — | | — | | ✓ | | ✓ | — |
| Actuator | | | | | | | | |
| Plain plunger | — | ✓ | — | | ✓ | | ✓ | ✓ |
| Rounded plunger | ✓ | | | ✓ | | | ✓ | ✓ |
| Roller plunger | ✓ | | | ✓ | | | ✓ | ✓ |
| Roller lever | ✓ | | | ✓ | | | ✓ | ✓ |
| Angular roller lever | ✓ | | | ✓ | | | ✓ | ✓ |
| Spring rod | ✓ | | | ✓ | | | ✓ | ✓ |
| Twist lever | ✓ | | | ✓ | | | ✓ | ✓ |
| Adjustable-length twist lever and rod lever | ✓ | | | ✓ | | | ✓ | ✓ |
| Fork lever | ✓ | | | ✓ | | | ✓ | ✓ |





✓

Available for delivery

—

Not available

3.5 Overview of safety switches

| | Safety switches with separate actuation | | | | Safety switches with tumbler |
|---|---|---|--|---|---|
| | 3SE5212-..V40 3SE5232-..V40 | 3SE5242-..V40 | 3SE5112-..V10 3SE5132-..V20 | 3SE5122-..V10 | 3SE5322-.S... 3SE5312-.S... |
| |  |  |  |  |  |
| Enclosure | | | | | |
| Plastic (1) | ✓ | ✓ | ✓ | — | ✓ |
| Metal (2) | ✓ | — | ✓ | ✓ | ✓ |
| Dimensions (W x H x D) in mm | | | | | |
| | 31 x 68 x 33 | 50 x 53 x 33 | 40 x 78 x 38 | 56 x 78 x 38 | 54 x 185 x 44 |
| Degree of protection | (1) IP65 (2) IP66/67 | (1) IP66/67 | (2) IP66/67 | | (1)(2) IP66/67 |
| Standards | | | | | |
| | IEC 60947-5-1 | | | | |
| Mounting according to standard | EN 50047 | | EN 50041 | | DIN EN ISO 14119 |
| 2 slow-action contacts | 1 NO + 1 NC | | | | — |
| 3 slow-action contacts | 1 NO + 2 NC | | | | — |
| 6 slow-action contacts | — | | | | 2 x (1 NO + 2 NC) |
| LED display | ✓ | | | | ✓ |
| Rated insulation voltage U _i | 400 V | | | | 250 V |
| Conventional thermal current I _{the} | 6 A | | | | 6 A |
| Cable routing | 1 x (M20 x 1.5) | 2 x (M20 x 1.5) | 1 x (M20 x 1.5) | 3 x (M20 x 1.5) | 3 x (M20 x 1.5) |
| M12 connector, 4-pin or 5-pin | ✓ | | | | — |
| Connector, 6-pin + PE | — | ✓ | — | ✓ | — |
| Separate actuation | ✓ | | | | ✓ |

✓ Available for delivery

— Not available





3.6 Overview of 3SE22 safety switches

| Molded-plastic enclosures in special width of 52 mm, lateral and front-end actuation | 3SE2243-0XX.0 | 3SE2257-6XX.0 | 3SE2243-0XX.8 | 3SE2257-6XX.8 |
|--|--|---------------|---------------|---------------|
| |  | | | |
| With M20 x 1.5 connecting thread | ✓ | ✓ | — | — |
| With M16 x 1.5 connecting thread | — | — | ✓ | ✓ |
| Slow-action contacts | 1 NO + 2 NC | 1 NC | 1 NO + 2 NC | 1 NC |
| Holding force 5 N | 3SE2243-0XX40 | 3SE2257-6XX40 | 3SE2243-0XX48 | 3SE2257-6XX48 |
| Holding force 30 N | 3SE2243-0XX | 3SE2257-6XX | 3SE2243-0XX18 | 3SE2257-6XX18 |
| With automatic ejection | 3SE2243-0XX30 | 3SE2257-6XX30 | 3SE2243-0XX38 | 3SE2257-6XX38 |
| Degree of protection | IP67 | IP67 | IP67 | IP67 |
| Stroke | 6 mm | 6 mm | 6 mm | 6 mm |

✓ Available for delivery

— Not available



3.7 Overview of mechanical safety switches for AS-Interface

| | Mechanical safety switches with separate actuation | | | | Safety switches with tumbler |
|--|---|---|---|---|---|
| | 3SF1214 3SF1234 | 3SF1244 | 3SF1114 | 3SF1124 | 3SF13.4 |
| |  |  |  |  |  |
| Enclosure | | | | | |
| Plastic (1) | ✓ | ✓ | — | — | ✓ |
| Metal (2) | ✓ | — | ✓ | ✓ | ✓ |
| Dimensions (W x H x D) in mm | | | | | |
| | 31 x 68 x 33 | 50 x 53 x 33 | 40 x 78 x 38 | 56 x 78 x 38 | 54 x 85 x 44 |
| Degree of protection | IP65 | IP66/67 | IP66/67 | IP66/67 | IP66/67 |
| Standards | IEC 60947-5-1 | IEC 60947-5-1 | IEC 60947-5-1 | IEC 60947-5-1 | IEC 60947-5-1 |
| Mounting according to standard | EN 50047 | EN 50047 | EN 50041 | EN 50041 | DIN EN ISO 14119 |
| 2 slow-action contacts | 1 NO + 1 NC | 1 NO + 1 NC | 1 NO + 1 NC | 1 NO + 1 NC | — |
| 3 slow-action contacts | 1 NO + 2 NC | 1 NO + 2 NC | 1 NO + 2 NC | 1 NO + 2 NC | — |
| 6 slow-action contacts | — | — | — | — | 2 x (1 NO + 2 NC) |
| Rated insulation voltage U_i | 400 V | 400 V | 400 V | 400 V | 250 V |
| Conventional thermal current I_{the} | 6 A | 6 A | 6 A | 6 A | 6 A |
| Cable routing | 1 x (M20 x 1.5) | 2 x (M20 x 1.5) | 1 x (M20 x 1.5) | 3 x (M20 x 1.5) | 3 x (M20 x 1.5) |
| M12 connector, 4-pin or 5-pin | ✓ | ✓ | ✓ | ✓ | — |
| Connector, 6-pin + PE | — | — | ✓ | ✓ | — |
| AS-Interface | ✓ | ✓ | ✓ | ✓ | ✓ |
| Separate actuation | ✓ | ✓ | ✓ | ✓ | ✓ |

✓ Available for delivery

— Not available

3.8 Overview of hinge switches

| | Hinge switches | | | |
|--|---|-----------------|---|-----------------|
| | 3SE5232-0.U2. | 3SE5212-0.U2. | 3SE5112-0.U2. | 3SE5132-0.U2. |
| |  | |  | |
| Enclosure | | | | |
| Plastic | ✓ | — | — | ✓ |
| Metal | — | ✓ | ✓ | — |
| Dimensions (W x H x D) in mm | 31 x 68 x 33 | 31 x 68 x 33 | 40 x 78 x 38 | 40 x 78 x 38 |
| Degree of protection | IP65 | IP66/67 | IP66/67 | IP66/67 |
| Standards | IEC 60947-5-1 | | | |
| Mounting and operating points according to standard | EN 50047 | EN 50047 | EN 50041 | EN 50041 |
| 2 snap-action contacts | 1 NO + 1 NC | 1 NO + 1 NC | 1 NO + 1 NC | 1 NO + 1 NC |
| 3 snap-action contacts | 1 NO + 2 NC | 1 NO + 2 NC | 1 NO + 2 NC | 1 NO + 2 NC |
| Increased anti-corrosion protection | ✓ | ✓ | ✓ | ✓ |
| Rated insulation voltage U _i | 400 V | 400 V | 400 V | 400 V |
| Cable routing | 1 x (M20 x 1.5) | 1 x (M20 x 1.5) | 1 x (M20 x 1.5) | 1 x (M20 x 1.5) |
| With hollow or solid shaft | ✓ | ✓ | ✓ | ✓ |



Available for delivery



Not available

General description

3.8 Overview of hinge switches

| Plastic enclosures with integrated hinge | 3SE2283-0GA.3 | 3SE2283-6GA.3 | 3SE2283-0GA44 | 3SE2283-6GA44 |
|--|--|-----------------|-----------------|-----------------|
| |  | | | |
| Aluminum hinge | ✓ | ✓ | — | — |
| High-grade steel hinge | — | — | ✓ | ✓ |
| Slow-action contacts | 1 NO + 2 NC | 3 NC | 1 NO + 2 NC | 3 NC |
| 4 °actuating angle | 3SE2283-0GA43 | 3SE2283-6GA43 | 3SE2283-0GA44 | 3SE2283-6GA44 |
| 8 °actuating angle | 3SE2283-0GA53 | 3SE2283-6GA53 | — | — |
| Rated insulation voltage U _i | 250 V | 250 V | 250 V | 250 V |
| Degree of protection | IP65 | IP65 | IP65 | IP65 |
| Cable entry | 2 x (M20 x 1.5) | 2 x (M20 x 1.5) | 2 x (M20 x 1.5) | 2 x (M20 x 1.5) |

✓ Available for delivery

— Not available

3.9 Overview of magnetically operated switches

3.9.1 3SE66/3SE67 non-contact magnetically operated safety switches

| | 3SE6704-1BA | 3SE6605-1BA | 3SE6704-2BA | 3SE660.-2BA | 3SE6704-3BA | 3SE6605-3BA |
|-----------------------|---|---|---|---|---|---|
| |  |  |  |  |  |  |
| | Switching magnet (coded) | Contact block | Switching magnet (coded) | Contact block | Switching magnet (coded) | Contact block |
| Size (mm) | M30 | M30 | 25 x 88 | 25 x 88 | 25 x 33 | 25 x 33 |
| Contacts | — | 1 NO + 1 NC 2 NC | — | 1 NO + 1 NC 2 NC | — | 1 NO + 1 NC 1 NO + 2 NC |
| With 1 m cable | — | — | — | — | — | 3SE6606-3BA |
| With 3 m cable | — | 3SE6605-1BA | — | 3SE6605-2BA 3SE6604-2BA 3SE6606-2BA04 | — | 3SE6605-3BA |
| With 5 m cable | — | — | — | 3SE6605-2BA05 | — | 3SE6605-3BA05 |
| With 10 m cable | — | — | — | 3SE6605-2BA10 3SE6604-2BA10 | — | 3SE6605-3BA10 |
| With 15 m cable | — | — | — | — | — | 3SE6605-3BA15 |
| With 25 m cable | — | 3SE6605-1BA25 | — | — | — | 3SE6605-3BA25 |
| With M8 plug, 4-pole | — | — | — | 3SE6605-2BA01 3SE6604-2BA01 | — | — |
| With M12 plug, 4-pole | — | 3SE6605-1BA02 | — | — | — | — |







Available for delivery



Not available

General description

3.9 Overview of magnetically operated switches

| | Enclosures, plastic | | | | | |
|------------------------------|---|---|---|--|---|---|
| | 3SE66.6-3CA01 | | 3SE66.7-3CA01 | | 3SE66.7-3CA04 | |
| |  |  |  |  |  |  |
| With 8 mm plug, 6-pole | ✓ | | ✓ | | — | |
| With cable | — | | — | | ✓ | |
| Door hinge right | 3SE6626-3CA01 | | 3SE6627-3CA01 | | 3SE6627-3CA04 | |
| Door hinge left | 3SE6616-3CA01 | | 3SE6617-3CA01 | | 3SE6617-3CA04 | |
| Dimensions (W x H x D) in mm | 26 x 36 x 13 | | 26 x 36 x 13 | | 26 x 36 x 13 | |
| Degree of protection | IP67 | | IP67 | | IP67 | |
| Approvals | cULus | | cULus | | cULus | |
| Safety contacts | 1 NO + 1 NC | | 2 NC | | 2 NC | |
| Signaling contacts | 1 NC | | 1 NC | | 1 NC | |

✓ Available for delivery

— Not available

| | Enclosures, plastic | | | | | |
|------------------------------|---|---|---|--|---|---|
| | 3SE66.7-2CA01 | | 3SE66.4-4CA01 | | 3SE66.7-2CA04 | |
| |  |  |  |  |  |  |
| With 8 mm plug, 6-pole | ✓ | | — | | — | |
| With LED and plug, 4-pole | — | | ✓ | | — | |
| With cable | — | | — | | ✓ | |
| Door hinge right | 3SE6627-2CA01 | | 3SE6624-4CA01 | | 3SE6627-2CA04 | |
| Door hinge left | 3SE6617-2CA01 | | 3SE6614-4CA01 | | 3SE6617-2CA04 | |
| Dimensions (W x H x D) in mm | 25 x 88 x 13 | | 25 x 88 x 13 | | 25 x 88 x 13 | |
| Degree of protection | IP67 | | IP67 | | IP67 | |
| Approvals | cULus | | cULus | | cULus | |
| Safety contacts | 2 NC | | 2 NC | | 2 NC | |
| Signaling contacts | 1 NC | | — | | 1 NC | |







Available for delivery



Not available

General description

3.9 Overview of magnetically operated switches

| Contact blocks | 3SE6714-3CA | 3SE6724-3CA | 3SE6714-2CA | 3SE6724-2CA |
|--|---|---|--|---|
| |  |  |  |  |
| Offset by 90 degrees | — | ✓ | — | ✓ |
| Suitable for 3SE6626-3CA01 3SE6627-3CA01 3SE6616-3CA01 3SE6617-3CA01 3SE6617-3CA04 3SE6627-3CA04 | ✓ | ✓ | — | — |
| Suitable for 3SE6627-2CA01 3SE6617-2CA01 3SE6624-4CA01 3SE6614-4CA01 3SE6627-2CA04 3SE6617-2CA04 | — | — | ✓ | ✓ |

✓ Available for delivery

— Not available

3.9.2 Monitoring unit

| | |
|------------------------------|---|
| | Safety relay |
| | 3SE6806-2CD00 |
| |  |
| With relay output | 6-fold |
| Rated control supply voltage | 24 V DC |
| Number of encoders | 6 |
| Enabling/signaling circuits | 2 NO/1 NC |

Note

You will find additional information in Chapter "Safety relays (Page 224).

3.10 Features of position switches

3.10.1 Basic function

Mechanical position switches and mechanical safety switches for safety-related applications ensure safe interruption of a circuit when required. For example, actuators are safely switched off by actuating the position switch, thereby preventing injuries to persons and damage to machines. The mechanical position switches and mechanical safety switches implement the safe shutdown without any action on the part of the machine control system, e.g., PLC.

3.10.2 Electromechanical sensors

Due to certain mechanical advantages, position switches are used in automatic control systems and in many other applications under a variety of service conditions.

They transmit information to the control system on the following:

- Presence/absence of objects
- Running-past of an object
- Position of an object
- End position of an object
- Status of protective doors

Electrical features

- Electrically isolated auxiliary switch
- Very high switching capacity when switching low currents and, depending on the version, a high level of fail-safe operation
- High short-circuit strength in combination with the assigned backup fuse
- Absolute protection against electromagnetic interference
- High operating voltage permitted

Mechanical features

- Positively-driven actuation of the normally closed auxiliary switch (positive opening operation ⊕)
- High level of resistance in industrial environment (tests according to standardized and special ambient conditions)
- Operating point repeatability up to 0.05 mm

3.10.3 Contact element variance

Variants: 1 NO +1 NC, 1 NO + 2 NC, 2 NO + 1 NC, make-before-break

The 3-pin contact block increases the safety through redundant switch-off and additional signaling. Additional available space is not required compared to 2-pin contact blocks.

Snap-action contacts

- Simultaneous switching of all contacts irrespective of the actuating speed
- Operating point independent of actuating speed $v_{\min} = 0.1 \text{ mm/s}$
- No contact erosion
- Hysteresis is approximately 30% to 40% of the operating travel

The hysteresis describes the difference between the operating point and reset point in the case of snap-action contacts.

Snap-action contacts, short-stroke

Improved precision through reduced actuator travel.

Snap-action contacts 2 x 2 mm

Operating distance for elevator industry enables simultaneous switch-off and signaling.

Slow-action contacts

- Travel difference (current-free pause, make-before-break) between normally open contact and normally closed contact.
- The normally closed contact always opens first before the normally open contact closes.
- The operating time is dependent on the actuating speed
Actuating speed $v_{\min} = 0.4 \text{ mm/s}$. The operating speed is identical or proportional to the actuating speed.
- Operating point dependent on contact erosion/aging
- No hysteresis

Slow-action contact with make-before-break

This variant is used to introduce a second function to a sequential control system.

One of the two normally closed contacts opens first.

The second normally closed contact only opens once the normally open contact is closed.

Gold-plated contacts

Used for applications with low currents, low switching frequency, corrosive vapors/atmospheres.

Contact reliability

The new contact blocks guarantee a very high level of contact reliability. This is also the case when the devices are required to switch low currents and voltages, such as 1 mA at 5 V DC.

Positive opening operation

The contacts with normally closed function are opened reliably by means of a positively-driven actuating plunger mechanism. This is referred to as a positive opening operation.

IEC 60947-5-1 and DIN EN 60947-5-1 require positive opening of normally closed contacts for operator protection and stipulate use of the marking .

Positive opening travel

A manufacturer-specified minimum travel that ensures that all main contacts are in open position when the operator control element is in the position corresponding to the open position of the switching device.

Positive opening position switches with slow-action function, snap-action function, and slow-action function with make-before-break

On actuation, the positive opening normally closed contact opens and reaches its positive opening point in a defined manner. On reset (closing of protective device), the contact closes at the same point (no hysteresis) in the case of slow-action contacts.

When using switches with slow-action contacts, you should observe the manufacturer's specifications with respect to operating travel diagrams and actuator travel. The installation of switches must ensure their complete mechanical actuation such that the necessary positive opening travel is achieved.

Position switches with snap-action contacting are recommended in the case of very slow actuating speeds and for applications in which the contacts are to switch with almost no delay. If the snap-action contact block fails, the positive opening operation  is initiated by a deflection mechanism.

Recognition features for safety switches

The yellow covers on switches with separate actuation with and without tumbler, hinge switches, and AS-Interface indicate that the switch is a safety switch.

For mechanical position switches with positive opening operation , you can replace the turquoise cover with a yellow cover to enable visual recognition of the position switch as a safety switch.

Overtravel

The overtravel enables actuation of the actuator head to the endstop without damaging the contact block. The overtravel provides a certain extra travel by means of an additional spring. The positive opening operation is ensured by a so-called overtravel plunger.

Membranes

Two kinds of integrated membranes are available for selection for all enclosure variants:

- Chlorinated rubber membrane for normal applications to protect against dust and moisture
- Silicone membrane for high operational reliability at low temperatures (down to -40 °C) and in aggressive environments

3.10.4 Article No. scheme

The article number of a position switch follows the following scheme:

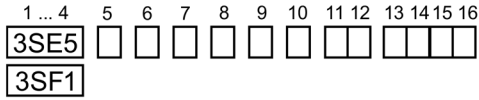

| Digit | | Digit | |
|-----------------|---|---------|---|
| 3SE5 1 ... 4 | Mechanical position switch Mechanical safety switch | 8 | LED display |
| 3SF1 1 ... 4 | Mechanical safety switch for AS-Interface | 9 | Contact variants 1 contact block, except 3SE516 2 contact blocks, 3SE516 only |
| 5 | 0 = Spare parts/modules 1 = Design according to EN 50041 2 = Design according to EN 50047 3 = Separate actuator with tumbler 4 = Compact design | 10 | Actuator type |
| 6 | Enclosure design | 11 - 12 | Actuator variant (plastic/metal) |
| 7 | Device connection | 13 - 16 | Various variant descriptions |

3.10.5 Selection of 3SE position switches

Position switches are used to detect the position of moving machine parts, doors, objects, etc. and to convert the position to electrical signals, which are then processed in control systems.

Position switches are differentiated as follows:

- Position switches **without** separate actuation
- Position switches **with** separate actuation

The position switches without separate actuation are available in four variants. They differ in their dimensions, technical data, and possible uses.

| Enclosure | Enclosure width | Degree of protection |
|-----------------------|-----------------|------------------------------|
| Open-type design | 30 mm | IP10 (3-pin) IP20 (2-pin) |
| Plastic | 31 mm | IP65 |
| | 40 mm/50 mm | IP66/IP67 |
| Metal | 31 mm | IP66/IP67 |
| | 40 mm | |
| | 56 mm/56 mm XL | |
| Compact design, metal | 30 mm | IP67 |
| | 40 mm | |

Note

3SE5000 contact blocks without enclosure have the IP00 degree of protection.

The position switches with separate actuation are differentiated as follows:

| Enclosure | Enclosure width | Degree of protection |
|---|---------------------|----------------------|
| Position switches with separate actuator without tumbler | | |
| Plastic | 31 mm | IP65 |
| | 40 mm/50 mm | IP66/IP67 |
| Metal | 31 mm, 40 mm, 56 mm | IP66/IP67 |
| Position switches with separate actuator with tumbler | | |
| Plastic/metal | 54 mm | IP66/IP67 |

The actuator is triple coded to prevent it from being manipulated easily.

Note

The dimensions and drilling dimensions of the 30 mm, 31 mm, and 50 mm-wide enclosures are according to EN 50047.

The dimensions and drilling dimensions of the 40 mm and 56 mm-wide enclosures are according to EN 50041.

3.10.6 Online configuration

3.10.6.1 Use of the online configurator

The online Configurator (<http://www.siemens.com/industrial-controls/configurators>) enables you to select and order the appropriate position switch as well as generate a complete set of product documentation:

- Product data sheet
- Dimension drawings
- Operating travel diagram
- CAD data in 2-D and 3-D model images
- Ordering data
- Product photo

The configurator allows you to select which position switch out of the comprehensive product range best suits the requirements of each application.

3.10.6.2 Application of the online configurator

Configuration via direct entry

To configure a position switch, proceed as follows:

1. Open the overview page of Configurators (<http://www.siemens.com/industrial-controls/configurators>)
2. In the drop-down list box "Select a configurator", select "3SE5/3SF1 Position Switches".
3. If you already know the article number for a device and you only need a data sheet or the CAD data for this device, you can enter the article number in the corresponding fields under "Input complete unit", "Input basic switch", "Input operating mechanism", or "Input actuator".

Input complete unit:

Input basic switch:
Input operating mechanism:
Input actuator:

"Input complete unit:"

Note

Direct entry

For safety switches with separate actuator with or without tumbler, you can enter **only** the basic switch directly with the article number. The actuator must be selected in the selection menu.

Configuration via selection

To configure a position switch, proceed as follows:

1. Open the overview page of Configurators (<http://www.siemens.com/industrial-controls/configurators>)
2. In the drop-down list box "Select a configurator", select "3SE5/3SF1 Position Switches".

3. Click "Start".

Industrial Controls

Product Information ▾ **Configurators**

Select a configurator 3SE5/3SF1 Position Switches ▾

3SE5/3SF1 Position Switches

There is a lot of information out there. And to ensure correct and precise recording of all available data, reliable devices are required.

The new generation of 3SE5/3SF1 position switches is characterized by modern design, innovative technology and simple installation.

The configurator allows easy selection of the best device for each application from this comprehensive range of position switches.

For example, if you already know the order data for a device, and simply require a data sheet or the CAD data, just enter the order number into the appropriate field (direct input complete or components) and you will receive the desired information.

Start

4. Select the device type (e.g. mechanical position switch) and other characteristics.
5. Select "Position Switch > Configuration of Switches".
6. Select the desired features.

7. Once you have specified all values, a CAD preview is generated.

Position Switch

Part list | **Result** | Documents | CAD

Print | Export as Excel

| Name | Order number | Properties |
|---------------------------|--------------------|--|
| Position Switch | | Device type: Standard position switch AS-i connection: without AS-i Special requirements: Without |
| Configuration of Switches | | Enclosure: Plastic 31 mm EN 50047 Device connection: M12 connector Pin configuration: M12 connector, 5-pole: PIN1=terminal21, PIN2=22, PIN3=13, PIN4=14, PIN5=ground LED LED Display: 24 V DC Contacts: Slow-action contacts 1NO/1NC Contact material: Silver alloy Type of operating mechanism: Roller plunger Operating mechanism material: Metal Actuator design: Stainless steel roller EN 50041, form C Designs: 2 LEDs 24 V DC, yellow + green, with M12 connector 5-pole PIN assignment: 1NC/1NO: PIN1=21, PIN2=22, PIN3=13, PIN4=14, PIN5= ground LED, LED green to 13, LED yellow to 14 |
| Basic Switch | 3SE5234-1BC05-1AF3 | |
| Operating mechanism | 3SE5000-0AD02 | |



8. To finish the configuration, click the "Display technical data & order" button.

9. Following configuration, you have the following options:

- "Part list" tab - Shows a listing of your selection, which you can display and print out automatically on an Excel spreadsheet for documentation purposes.
- "Result" tab - Shows your selection.
- "Documents" tab - Here, you can download and print the product data sheet in PDF format.
- "CAD" tab - Shows the CAD representation of the selection as a surface model, wire frame model, or 3-D applet and enables you to download the bitmap, dimension drawing, or 3-D model.

Ordering

After the configuration is complete, it is possible to order the switch directly in the online Catalog and Ordering System.

- Click the "Next" button to go to the ordering dialog where you can place your selection in the shopping cart.
Here, you can also generate an Excel spreadsheet containing the ordering data and/or print the displayed list.

Note

Registration

To place an order, you must have logged into Siemens Industry Mall
www.siemens.com/industrial-controls/mall (<http://www.siemens.com/industrymall>)
beforehand.

Position switches, safety switches, hinge switches and magnetically operated switches

4

No matter what the requirements, SIRIUS position switches can be used in practically any situation in day-to-day industrial operations. The following features make this possible:

- Modular structure
- Uniform structure
- Structure with many different variants available
- Wide variety of actuators

Standardized designs and functions make it easy to select the appropriate switch and ensure simple, efficient storage, installation, and wiring.

Together with fail-safe evaluation units, such as 3TK28, ASIsafe or SIMATIC and SINUMERIK units, you can achieve Category 4 according to ISO 13849-1 (EN 954-1).

Position switches are actuated by bars, cams, endstops, cam disks, etc. and provide control commands for the further

- sequence of the switch program,
- manufacturing sequence, and
- processing sequence.

A variety of device series with different contact versions are available for carrying out various control tasks.

- Position switches in open-type design (Page 48)
- Position switches in compact design (Page 53)
- Mechanical position switches (Page 63) with plastic enclosure/with metal enclosure
- Mechanical safety switches (Page 134)
- Mechanical safety switches with separate actuation (Page 147)
- Mechanical safety switches with tumbler (Page 155)
- Hinge switches (Page 177)
- Magnetically operated switches (Page 185)
- 3SF1 mechanical safety switches for AS-Interface (Page 208)

A variety of actuators are available for the various approach and actuation situations to enable an optimum solution. The different enclosure designs enable the most favorable conditions for installing and removing devices and the ideal electrical cable entry. The 3SE5 position switches guarantee operational reliability of controls by virtue of their design, materials, and manufacture.

4.1 Position switches in open-type design

The position switches in open-type design with degree of protection IP10 (3 contacts), IP20 (2 contacts), IP40 (contact chamber) are designed for the following:

- Use as auxiliary switches in cabinets
- Larger enclosures
- Locations not influenced by dust and moisture



Their compact design makes these switches particularly suitable for use in confined conditions. The mounting dimensions and operating points comply with EN 50047. The switches are equipped with two or three contacts:

- Snap-action contact
- Slow-action contact
- Slow-action contact with make-before-break

The travel is 6 mm. The empty enclosure can be equipped with any of the contact block variants.

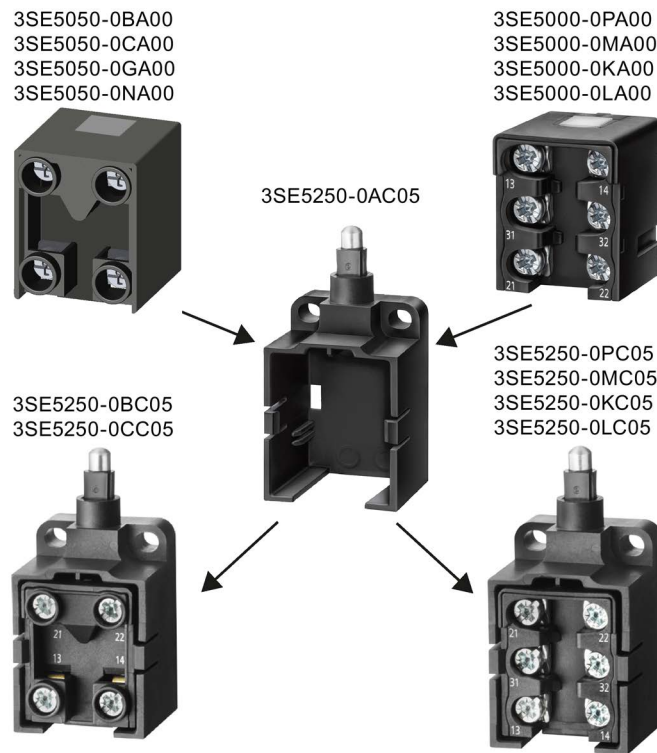

! WARNING

Risk of injury or death.

Use only the contact block with article number 3SE5050-.... as a 2-pin open-type position switch.

The 2-pin contact blocks with article numbers 3SE5000-.... and 3SE5060-.... must not be used as open-type position switches.

4.1 Position switches in open-type design

4.1.1 Technical data for position switches in open-type design

4.1.1.1 Technical data in Siemens Industry Online Support

Technical data sheet

You can also find the technical data of the product at Siemens Industry Online Support (<https://support.industry.siemens.com/cs/ww/en/ps/>).

1. Enter the full article number of the desired device in the "Product" field, and confirm with the Enter key.
2. Click the "Technical data link."

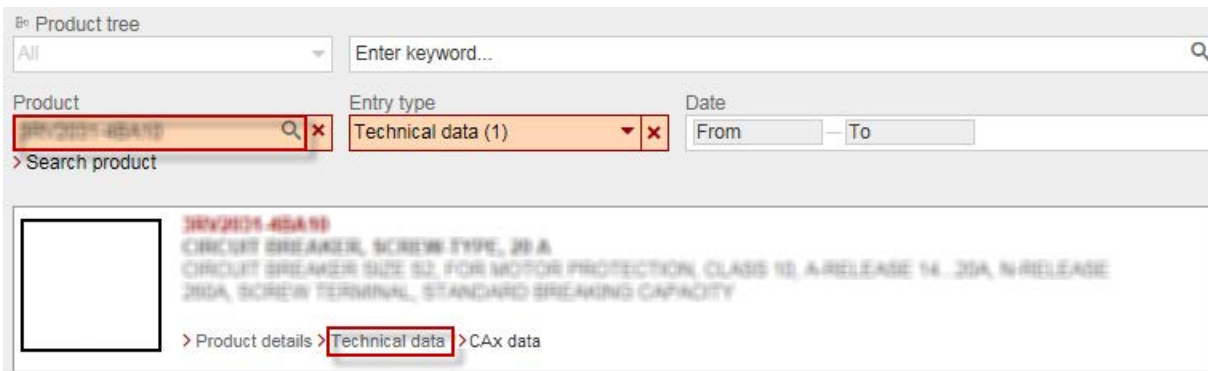

4.1.2 Dimension drawings and operating travel diagrams for position switches in open-type design

| | |
|---|--|
| <p>3SE5250-0PC05 3SE5250-0MC05 3SE5250-0KC05 3SE5250-0LC05</p> | <p>3SE5250-0BC05 3SE5250-0CC05</p> |
| | |
| <p>$v \leq 1.5 \text{ m/s}$ (maximum actuating speed) $F \geq 9 \text{ N}$ (minimum force demand in actuation direction)</p> | <p>$v \leq 1.5 \text{ m/s}$ (maximum actuating speed)</p> |

4.1 Position switches in open-type design

| Slow-action contacts | | | With make-before-break |
|--|--|--|--|
| <p>1 NO + 1 NC</p> <p>Code number 11</p> | <p>1 NO + 2 NC</p> <p>Code number 12</p> | <p>2 NO + 1 NC</p> <p>Code number 21</p> | <p>1 NO + 2 NC</p> <p>Code number 12</p> |
| Actuation in travel direction | | | |
| <p>3SE5250-0BC05</p> | <p>3SE5250-0KC05</p> | <p>3SE5250-0PC05</p> | <p>3SE5250-0MC05</p> |

| Snap-action contacts | |
|---|--|
| <p>1 NO + 1 NC</p> <p>Code number 11</p> | <p>1 NO + 2 NC</p> <p>Code number 12</p> |
| Actuation in travel direction | |
| <p>3SE5250-0CC05</p> | <p>3SE5250-0AC05 + 3SE5050-0NA00 ¹⁾</p> <p>Short stroke</p> |
| <p>3SE5250-0AC05 + 3SE5050-0GA00 ¹⁾</p> <p>Operating distance 2 x 2 mm</p> | <p>3SE5250-0LC05</p> |
| <p>¹⁾ Empty enclosure and contact blocks must be ordered separately.</p> | |

- Positive opening operation according to EN 60947-5-1
- Direction of actuation
- Contact element closed
- Contact element open
- Maximum actuator travel

4.2 Position switches in compact design

Enclosure sizes

The 3SE54 position switches in compact design are available as complete units in two enclosure sizes:

- Enclosure series 3SE5413 conforms to EU standards and has a 30 mm-wide enclosure. The fastening holes are spaced 20 mm apart.
- The enclosure series 3SE5423 conforms to requirements of the U.S. market and has a 40 mm-wide enclosure. The fastening holes are spaced 25 mm apart.

Position switches with molded cable or connector have the following advantages:

- Compact design (small enclosure sizes)
- Metal enclosure
- Simple multi-switch configuration
- Degree of protection IP67
- Large selection of actuators

Applications

- Lifting means
- Door monitoring (e.g., on trains)
- Construction machinery
- Elevators
- Mechanical equipment

Terminals

Devices are offered with

- 2 m cable (3SE54.-1EA2)
- 5 m cable (3SE54.-1EA5)
- Variants with M12 connector (3SE54.-1EB1)

4.2 Position switches in compact design

Switch variants with molded cable or connector - 30 mm enclosure width

3SE5413



Switch variants with molded cable or connector - 40 mm enclosure width

3SE5423



4.2.1 Actuator heads for position switches in compact design with molded cable

| | | |
|---|---|---------------------------|
| | 3SE5413-0CC20-.... | 3SE5423-0CC20-.... |
| H | 9.8 mm | 7.5 mm |
| | <p>Technical drawings showing the actuator heads for 3SE5413-0CC20-.... and 3SE5423-0CC20-.... The left drawing shows a side view with dimensions $\varnothing 12$ and $\varnothing 8$. The right drawing shows a top view with a downward force $F > 11\text{ N}$ and a height dimension H.</p> | |

| | | |
|---|--|---------------------------|
| | 3SE5413-0CC21-.... | 3SE5423-0CC21-.... |
| H | 24 mm | 24 mm |
| | <p>Technical drawings showing the actuator heads for 3SE5413-0CC21-.... and 3SE5423-0CC21-.... The left drawing shows a side view with dimensions $\varnothing 11.4$, $\varnothing 8$, and $\text{max. } 10$. The right drawing shows a top view with a downward force $F > 11\text{ N}$ and a height dimension H.</p> | |

| | | |
|---|---|---------------------------|
| | 3SE5413-0CC22-.... | 3SE5423-0CC22-.... |
| H | 19.8 mm | 16.7 mm |
| | <p>Technical drawings showing the actuator heads for 3SE5413-0CC22-.... and 3SE5423-0CC22-.... The left drawing shows a side view with dimensions $\varnothing 13.7$ and $\varnothing 7.1$. The right drawing shows a top view with a downward force $F > 11\text{ N}$ and a height dimension H.</p> | |

| | | |
|---|--|---------------------------|
| | 3SE5413-0CD20-.... | 3SE5423-0CD20-.... |
| | 3SE5413-0CD23-.... | 3SE5423-0CD23-.... |
| H | 20.3 mm | 20.3 mm |
| | <p>Technical drawings showing the actuator heads for 3SE5413-0CD20-...., 3SE5413-0CD23-...., and 3SE5423-0CD20-.... The left drawing shows a side view with dimension $\varnothing 12$. The right drawing shows a top view with a 30° angle, a downward force F, and a height dimension H. A dimension $\varnothing 12.5$ is also indicated.</p> | |

4.2 Position switches in compact design

| | 3SE5413-0CD21-.... | 3SE5423-0CD21-.... |
|---|---|--------------------|
| H | 35 mm | 35 mm |
| | <p>Technical drawing showing two views of compact design position switches. The left view shows a side profile with dimensions: a diameter of $\varnothing 11$ mm, a maximum height of $\text{max. } 10$ mm, and a diameter of $\varnothing 13$ mm. The right view shows a top-down perspective of the switch head with a height dimension H. A force $F > 11 \text{ N}$ is indicated acting on the top of the switch head, which is tilted at a 30° angle.</p> | |

| | 3SE5413-0CN20-.... | 3SE5423-0CN20-.... |
|---|--|--------------------|
| H | 44 mm | 44 mm |
| | <p>Technical drawing showing two views of compact design position switches. The left view shows a side profile with dimensions: a total width of 35.2 mm, a distance of 31.7 mm from the left edge to the center of the switch head, a distance of 12 mm from the center to the right edge, and a distance of 8.5 mm from the center to the bottom edge. The total height is H, and the distance from the bottom edge to the base is 16.5 mm. The right view shows a top-down perspective of the switch head with a width of 17 mm, a height of 9 mm, and a radius of $R 27$. A torque $M \geq 0.2 \text{ Nm}$ is indicated for the top edge, and a torque of 0.8 Nm is indicated for the bottom edge. The bottom edge is tilted at 15° angles on both sides. A 30° angle is also shown for the top edge.</p> | |

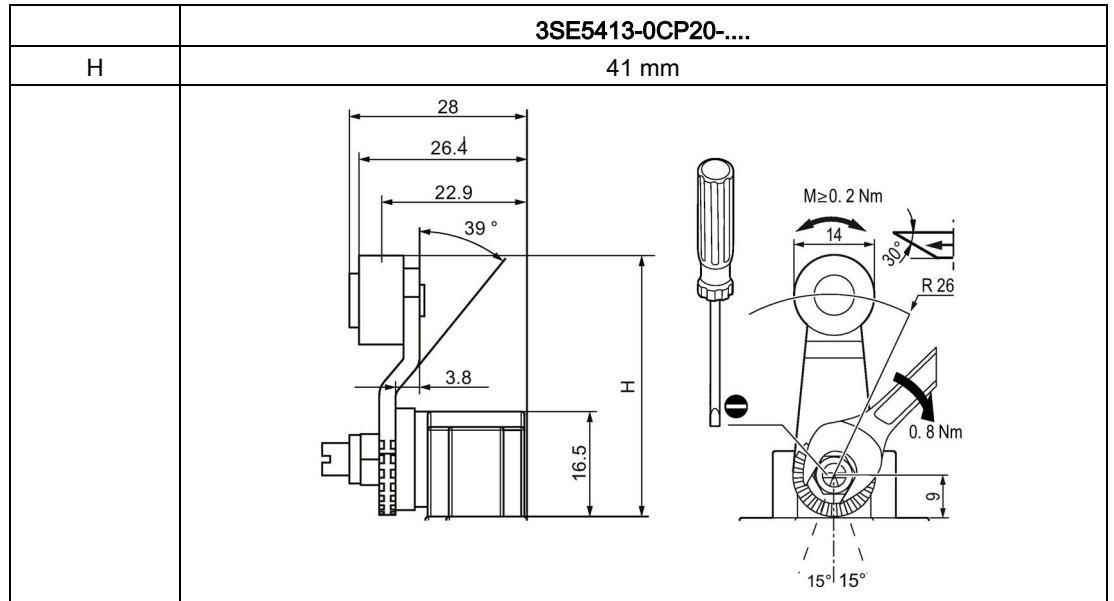

4.2.2 Mounting the actuator head

Rotating the actuator head

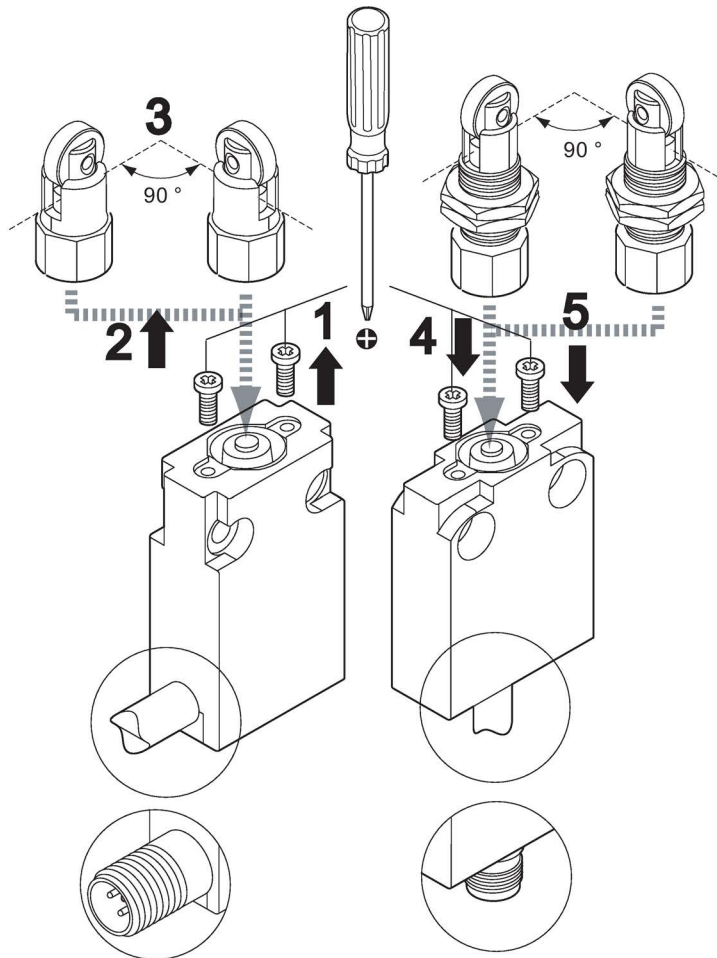

1. Use a cross-tip screwdriver to remove the two fixing screws of the drive head on the upper side of the enclosure.
2. Pull the drive head up and out of the enclosure.
3. Turn the drive head by 90 degrees.
4. Insert the drive head in the enclosure.
5. Fasten the drive head with the two fixing screws.

4.2.3 Technical data for position switches in compact design

4.2.3.1 Technical data in Siemens Industry Online Support

Technical data sheet

You can also find the technical data of the product at Siemens Industry Online Support (<https://support.industry.siemens.com/cs/ww/en/ps/>).

1. Enter the full article number of the desired device in the "Product" field, and confirm with the Enter key.
2. Click the "Technical data link."

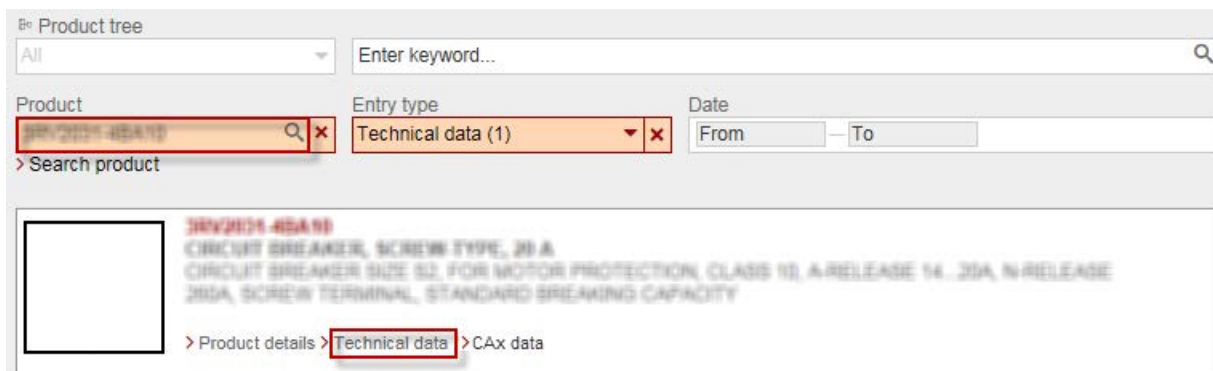

4.2.4 Dimension drawings and operating travel diagrams for position switches in compact design

3SE5413-0CC20-1EA2

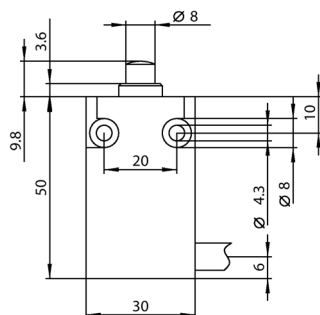

3SE5413-0CD20-1EA2

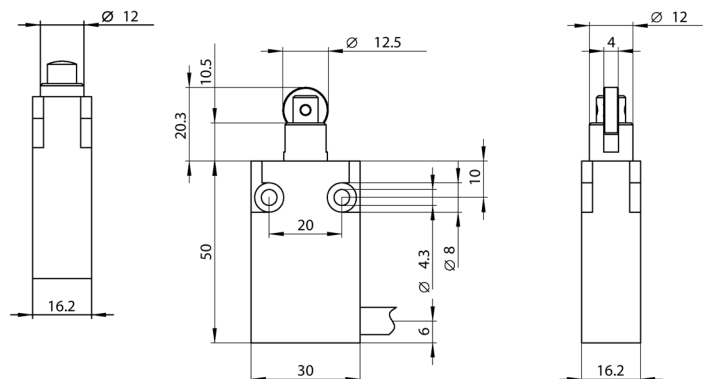

4.2 Position switches in compact design

3SE5413-0CN20-1EA2

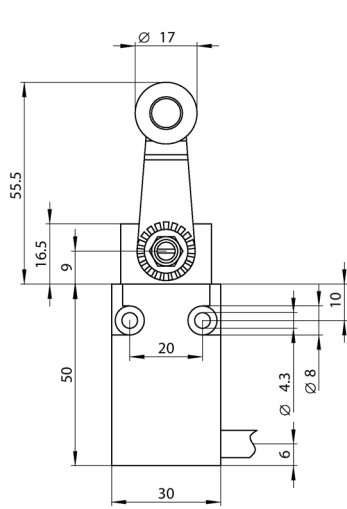

3SE5413-0CC20-1EB1

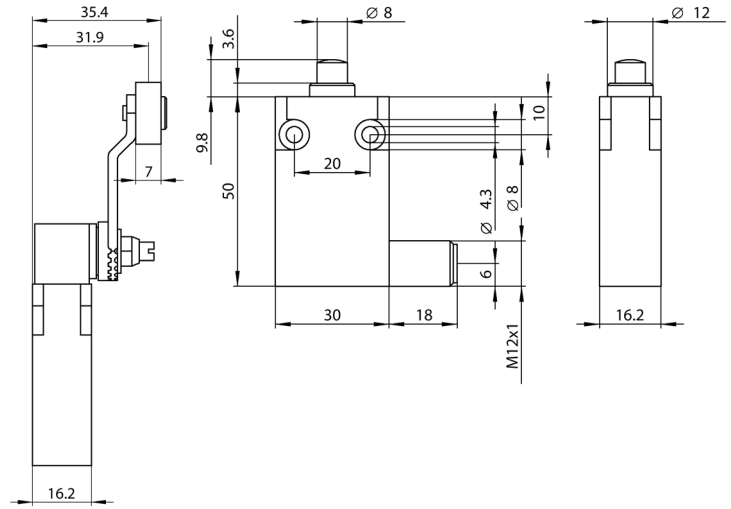

3SE5423-0CC20-1EA2

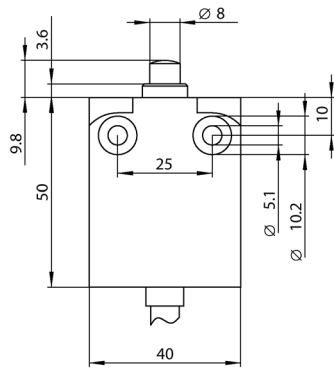

3SE5423-0CC20-1EB2

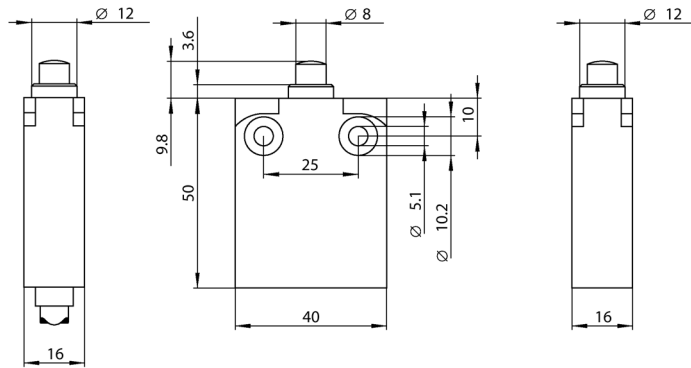

3SE5413-.....-1EA.

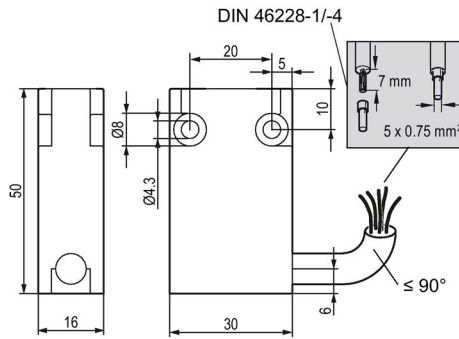

3SE5413-.....-1EB1

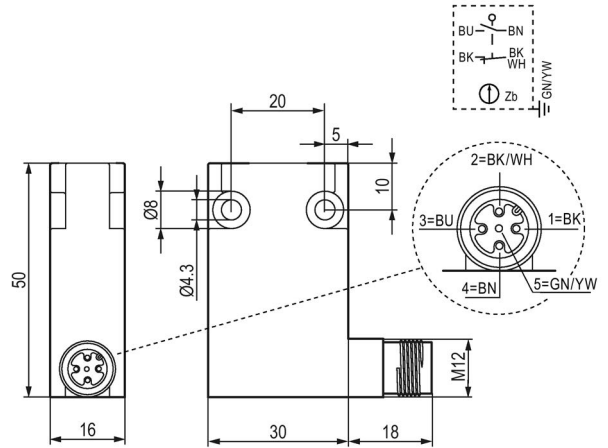

BK = black
WH = white

BU = blue
YW = yellow

BN = brown
GN = green

3SE5423-.....-1EA.

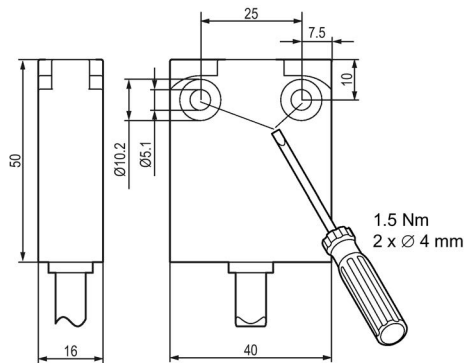

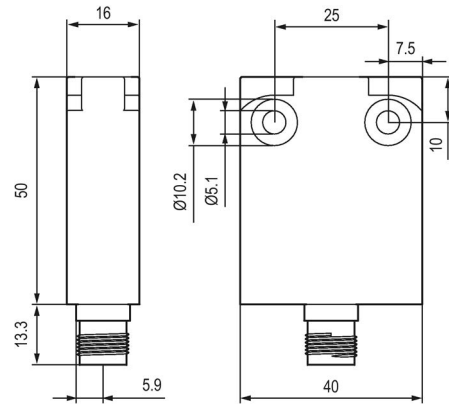

3SE5423-.....-1EB1

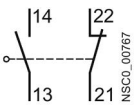
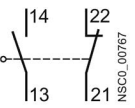
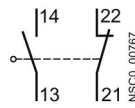
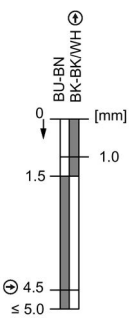
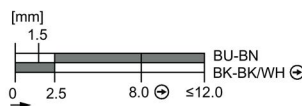
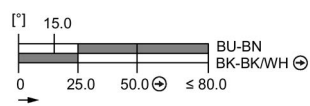

4.2 Position switches in compact design

Compact design 3SE54.3-0CC2.

| Snap-action contacts | | |
|--|--|--|
| <p>1 NO + 1 NC</p>  <p>Code number 11</p> | <p>1 NO + 1 NC</p>  <p>Code number 11</p> | <p>1 NO + 1 NC</p>  <p>Code number 11</p> |
| Actuation in travel direction | | |
| 3SE54.3-0CC2. | 3SE54.3-0CD2. | 3SE54.3-0CN2. |
|  |  |  |

- ⊕ Positive opening operation according to EN 60947-5-1
- Direction of actuation
-  Contact element closed
-  Contact element open
- ≤ Maximum actuator travel

BK = black
WH = white

BU = blue
YW = yellow

BN = brown
GN = green

4.3 Mechanical position switches

Modular system

The 3SE5 series is a modular system, consisting of the basic switch in various sizes and an actuator, which must be ordered separately. The modular switch design allows the user to choose the appropriate solution from a wide selection of options and to assemble it himself.



Figure 4-1 Examples of possible selections in the modular system

4.3.1 Plastic enclosure

The enclosure for these position switches is made of glass fiber-reinforced, flame-resistant plastic that is resistant to shock, impact, and drill oils. The cover is fastened with a captive screw. The cable entry features one M20 x 1.5 thread.

Note

In the case of position switches with integrated contact block, the bottom of the enclosure contains drill holes that enable mounting with M4 cylinder head screws.

Operating points, enclosure dimensions, and mounting dimensions for the 3SE52.. position switches, together with the respective actuators, conform to DIN EN 50047. The "Protective insulation" protective measure is achieved through the use of the plastic enclosure, thereby making connection of a protective conductor unnecessary. The enclosure is protected against ingress of dust and water jets from any direction. The contact pieces are pressed into the bottom of the enclosure (integrated) or a contact block is inserted inside an enclosure (replaceable). When the cover is open, the contact chamber is additionally covered to protect against ingress of foreign objects. The contact pieces are visible. Contact version 1 NO + 1 NC, 1 NO + 2 NC, and 2 NO + 1 NC.

The position switches are supplied with snap-action contacts, slow-action contacts, and slow-action contacts with make-before-break.

4.3 Mechanical position switches

Enclosure widths 31 mm, 40 mm, and 50 mm are available.



3SE5232-.....



3SE5132-.....



3SE5242-.....

In addition, different actuator variants are available. These can be attached to the rounded plunger (basic switch), which is affixed to the position switch enclosure (basic version). All actuators can be subsequently mounted onto the position switch enclosure or replaced with other actuator variants.

4.3.2 Metal enclosure

The position switch with metal enclosure consists of the three parts: basic enclosure, contact block, and actuator. The contact blocks are inserted inside the enclosure.

All contact blocks have a black plastic enclosure that holds the fixed contact pieces and the SIGUT terminals (captive screws).

The contact blocks can be used in standard enclosures with 2 or 3 contacts.



3SE5212-.....

3SE5112-.....

3SE5122-.....

3SE5162-.....

The enclosures, together with the corresponding actuators, conform to the standard position switches according to DIN EN 50041 or DIN EN 50047. The metal enclosures are corrosion-resistant and insensitive to impact, shock, and hot swarf.

The 40 mm wide enclosures satisfy degree of protection IP66/IP67 (complete touch protection/protection against harmful water in case of immersion). The standard enclosure is equipped with a choice of two diagonally arranged round holes or oblong holes for mounting purposes. The wide enclosure has oblong holes arranged on the left and right sides of the actuator. These enable an adjustment of the operating point during installation, if this adjustment cannot be made by means of the actuating element.

The 56 mm wide enclosure is provided with three threaded holes and the 31 mm and 40 mm wide enclosures with an M20 x 1.5 threaded hole for cable entry. The wide enclosure has more connection options because it also has a larger connection compartment.

The enclosure has a terminal for the protective conductor connection.

4.3 Mechanical position switches

4.3.3 Complete units

Frequently requested position switch variants in standard enclosures are offered as complete units.

Note

Variants for -40 °C

Variants that are suitable for ambient temperatures down to -40 °C can be ordered with the qualifiers -1AJ0, -1AJ1 or -1AY0 (e.g. 3SE5232-0LE10-1AY0).

Note

Variants with device plug

Variants with a fitted M12, 4-pole, 5-pole or 8-pole plug can be ordered under the article number 3SE5..4-....-1A... (e.g. 3SE5114-0CA00-1AC5). For the wide enclosures, plugs are available as accessories for user assembly.

Metal enclosures with 6-pole + PE device plugs can be ordered under the article number 3SE5..5-....-1A... (e.g. 3SE5114-0CA00-1AD0).

Enclosure width 31 mm - plastic/metal

3SE5232 / 3SE5212

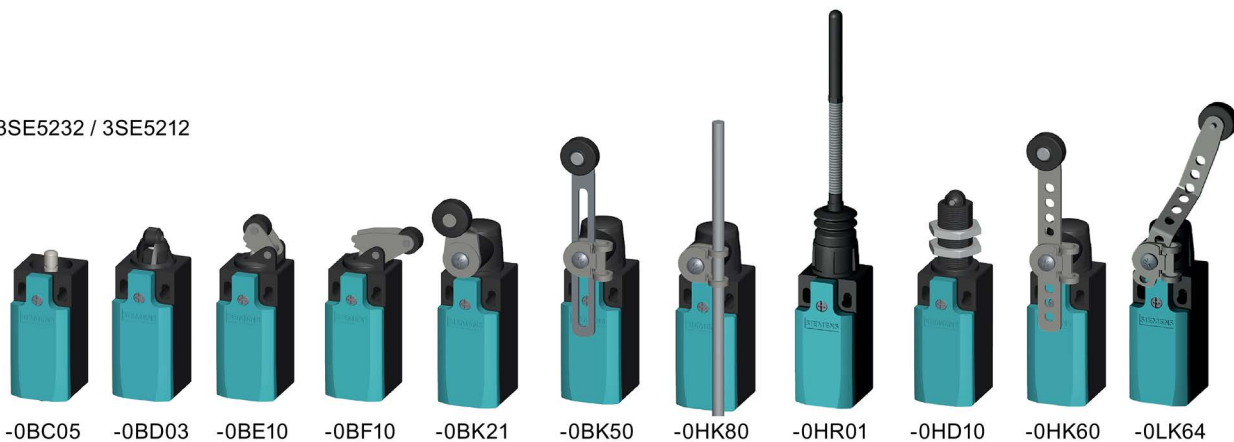

Enclosure width 40 mm - plastic/metal

3SE5132 / 3SE5112



Enclosure width 50 mm - plastic

3SE5242

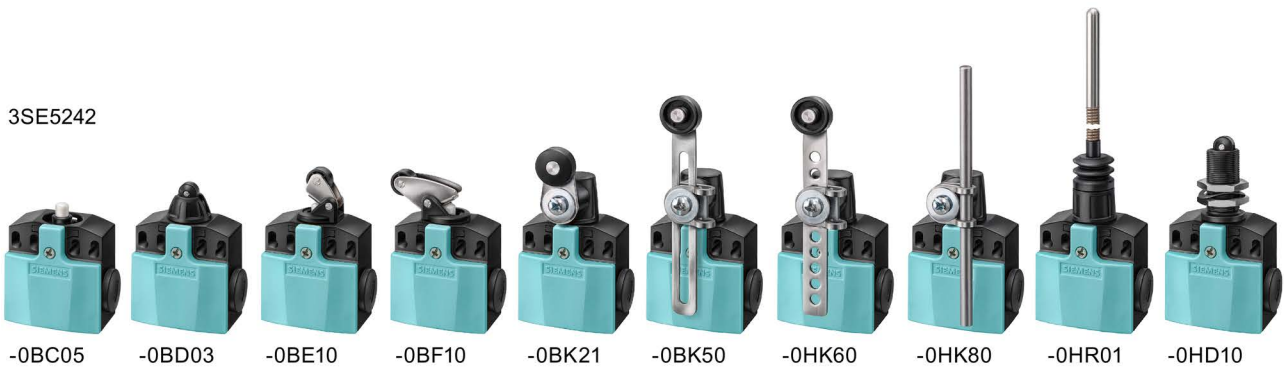

Enclosure width 56 mm - metal

3SE5122



4.3 Mechanical position switches

XL enclosure 56 mm - metal



4.3.4 Optional LED displays

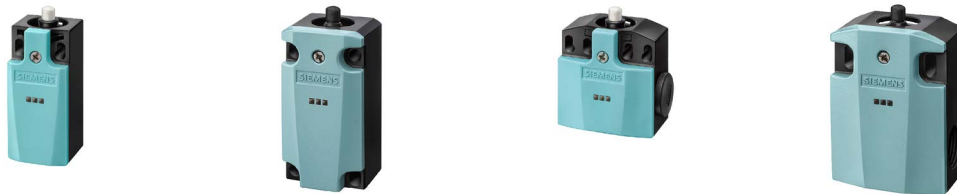

All enclosure variants (except XL enclosure) can be supplied with an LED display.

LED connection

Operating diagram 24 V DC
230 V AC

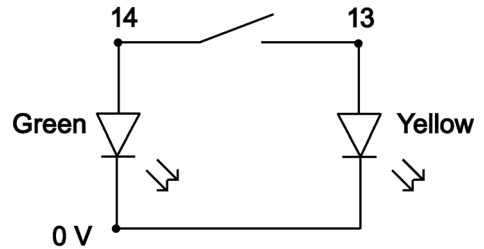

LED display

3 LEDs on the front panel indicate the switch position of the protective device.

| LED | No voltage | Voltage applied | Contact closed |
|-----|------------|-----------------|----------------|
| | ● | ● | ● |
| | LED off | LED lit green | LED lit yellow |

Note**Modified LED function in case of rotation of LED module**

Note that if the LEDs are rotated 180°, their function is modified. Safety contacts (NC) must not be queried by means of LEDs. The cable must be contacted using a commercially available terminal.

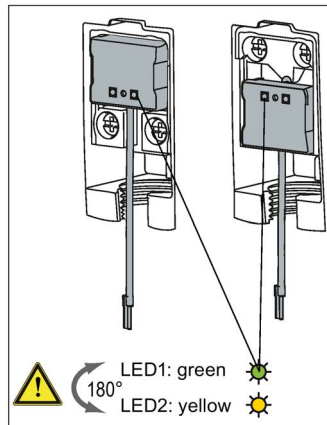

Figure 4-2 LED element rotated 180°

4.3.5 Enclosure

Enclosure cover

- The standard color of the enclosure covers with and without LED display is turquoise.
- These can be replaced with yellow covers with and without LED displays, which are available for all enclosure sizes (except XL enclosure).



- All LED enclosure covers are available for both plastic and metal enclosures.

4.3 Mechanical position switches

Enclosure sizes

The 3SE5 switches are available for delivery in eight different enclosure sizes:

- Position switches in open-type design, IP20 or IP10
- Position switches in compact design
- Plastic enclosure/metal enclosure according to EN 50047, 31 mm wide, 1 cable entry, IP65/IP66/IP67
- Plastic enclosure, 50 mm wide, 2 cable entries, IP66/IP67
- Plastic enclosure/metal enclosure according to EN 50041, 40 mm wide, 1 cable entry, IP66/IP67
- Metal enclosure, 56 mm wide and XL enclosure, 3 cable entries, IP66/IP67

Enclosure versions

With the enclosures, you can choose a basic switch from a wide range of options:

- With integrated contact block for 31 mm plastic switches, or with replaceable contact blocks including two or three contacts, available as slow-action contacts, snap-action contacts, and slow-action contacts with make-before-break
- With optional LED display
- With assembled M12 plug connector, 4-pin, 5-pin, or 8-pin (available as an accessory for self-assembly for the wide enclosure)
- With plug connector 6-pin + PE for metal enclosures
- With increased anti-corrosion protection
- Variants for operating temperatures down to -40 °C (-1AJ0)
- AS-Interface version with integrated ASIsafe electronics for all enclosure types

Actuator variants

The following actuator variants are available for delivery:

- Plain plunger
- Rounded plunger
- Roller plunger
- Roller lever
- Angular roller lever
- Spring rod
- Twist lever
- Adjustable-length twist lever with or without pre-drilled holes
- Rod lever
- Fork lever

The driving rollers are available in different materials and diameters.

4.3.6 Actuators and their actuation

There are currently 10 different actuator solutions available to satisfy a wide range of approach requirements.

These are distinguished by the following:

- The permissible type and direction of approach
- The actuating speed
- The actuating element design
- The favorable material pairing

All position switches operate independently of their position.

A position switch must be actuated for at least 0.1 s to ensure that the control command is forwarded reliably. The speed of the actuating element is designated as v (in m/s); the length l (in mm) of the actuating element is then calculated as $l \geq 0.1 \cdot v$. The same values apply with respect to the service life and switching frequency as for the contact block. All actuators are available for all enclosure sizes (3SE51, 3SE52). If the case of lateral actuation, the approach angle and trailing angle of the actuating element must be the same. The position switch must not be used as a mechanical endstop of a moving machine part under any circumstances. The actuators with central fixing M18 x 1 enable fast assembly and simple adjustment.

Possible uses

All actuators can be used for safety switches.

Exceptions:

- Spring rod
- Rod lever
- Adjustable-length twist lever with oblong hole without latching

The following actuator types are available:

- Plastic actuators for enclosure widths 31 mm and 50 mm according to EN 50047/40 mm according to EN 50041.
- Metal actuators for enclosure widths 40 mm and 56 mm according to EN 50041.
- All actuator heads can be rotated in 22.5 ° increments.

The actuator types have the same functionality, but different applications (see Application examples (Page 233))

4.3 Mechanical position switches

4.3.6.1 Plain plunger/rounded plunger



3SE5000-0AB01
Plain plunger



3SE5000-0AC02
Rounded plunger

| 3SE5000- | 0AB01 | 0AC02 | 0AC02-1AJ0 | 0AC03 | 0AC03-1AJ0 |
|-----------------------------|---------------------|---------------------|----------------------|---------------------|----------------------|
| For position switch | 3SE51/52 | 3SE51/52 | 3SE51 | 3SE5132 | 3SE5132 |
| According to standard | EN 50041 | EN 50041 | EN 50041 | EN 50041 | EN 50041 |
| Actuator head | Plastic | Metal | Metal | Plastic | Plastic |
| Stainless steel plunger | ✓ | ✓ | ✓ | — | — |
| Plastic plunger | — | — | — | ✓ | ✓ |
| Approach direction | In travel direction | In travel direction | In travel direction | In travel direction | In travel direction |
| Approach velocity v_{max} | 1.5 m/s | 1.5 m/s | 1.5 m/s | 1.5 m/s | 1.5 m/s |
| Overtravel | — | 3 mm | 3 mm | — | 3 mm |
| Special features | — | — | Functional at -40 °C | — | Functional at -40 °C |

Note

Some rounded plungers and roller plungers have a 3 mm overtravel and thus a longer actuator travel than other actuators.

Actuation in the travel direction has a positive effect on the service life because neither lateral forces nor friction occurs in this case.

4.3.6.2 Roller plunger



3SE5000-0AD02



3SE5000-0AD03 / 3SE5000-0AD04

| 3SE5000- | 0AD02 | 0AD03 | 0AD04 | 0AD05 | 0AD06 |
|---------------------------------------|----------------------------------|----------------------------------|----------------------------------|--|----------------------------------|
| For position switch | 3SE51/52 | 3SE51/52 | 3SE51/52 | 3SE5132 | 3SE5132 |
| According to standard | EN 50041 | EN 50047 | EN 50047 | EN 50041 | EN 50041 |
| Actuator head | Metal | Plastic | Plastic | Plastic | Plastic |
| Stainless steel roller | ✓ | — | ✓ | — | ✓ |
| Plastic roller | — | ✓ | — | ✓ | — |
| Roller Ø | 13 mm | 10 mm | 10 mm | 13 mm | 13 mm |
| Approach direction with switching bar | Perpendicular to the travel axis | Perpendicular to the travel axis | Perpendicular to the travel axis | Perpendicular to the travel axis | Perpendicular to the travel axis |
| Approach velocity v_{max} | 1 m/s | 1 m/s | 1 m/s | 1 m/s | 1 m/s |
| Overtravel | 3 mm | — | — | — | — |
| Special features | | | | Functional at -40 °C (0AD05-1AJ0 only) | |

The roller plunger is recommended in the case of lateral actuation and a relatively long overtravel distance.

Note

Some rounded plungers and roller plungers have a 3 mm overtravel and thus a longer actuator travel than other actuators.

4.3 Mechanical position switches

4.3.6.3 Roller plunger for central fixing



3SE5000-0AD10 / 3SE5000-0AD11

- Rapid installation
- Easy adjustment

| 3SE5000- | 0AD10 | 0AD11 |
|-----------------------------|--|----------------------------------|
| For position switch | 3SE51/52 | 3SE51/52 |
| According to standard | EN 50047 | EN 50047 |
| Actuator head | Plastic | Plastic |
| Stainless steel roller | — | ✓ |
| Plastic roller | ✓ | — |
| Roller Ø | 10 mm | 10 mm |
| Approach direction | Perpendicular to the travel axis | Perpendicular to the travel axis |
| Approach velocity v_{max} | 1 m/s | 1 m/s |
| Special features | <ul style="list-style-type: none"> • With thread M18 x 1 • Minimum actuation force in actuation direction 18 N | |

4.3.6.4 Roller lever



3SE5000-0AE1.



3SE5000-0AE0.

| 3SE5000- | 0AE10 / 0AE01 | 0AE11 / 0AE02 | 0AE12 / 0AE03 | 0AE13 / 0AE04 | 0AE05 |
|------------------------------|------------------------|------------------------|------------------------|------------------------|----------|
| For position switch | 3SE51/52 | 3SE51/52 | 3SE51/52 | 3SE51/52 | 3SE5132 |
| According to standard | EN 50047 / EN 50041 | EN 50047 / EN 50041 | EN 50047 / EN 50041 | EN 50047 / EN 50041 | EN 50041 |
| Actuator head | Plastic/metal | | | | Plastic |
| Stainless steel lever | — | — | ✓ | ✓ | — |
| Metal lever | ✓ | ✓ | — | — | ✓ |
| Stainless steel roller | — | ✓ | — | ✓ | — |
| Plastic roller | ✓ | — | ✓ | — | ✓ |
| Roller Ø | 13 mm / 22 mm | 13 mm / 22 mm | 13 mm / 22 mm | 13 mm / 22 mm | 22 mm |
| Approach direction only from | Right | Right | Right | Right | Right |
| Approach velocity v_{max} | 1 m/s | 2.5 m/s | 1 m/s | 2.5 m/s | 1 m/s |

Because the actuator is equipped with a plastic or stainless steel roller, it is especially well-suited for actuating elements made of finely-ground steel in the form of cams, bars, or cam discs without additional lubrication.

The roller levers are distinguished by a very long mechanical service life.

4.3 Mechanical position switches

4.3.6.5 Angular roller lever



3SE5000-0AF1.



3SE5000-0AF0.

| 3SE5000- | 0AF01 / 0AF10 | 0AF02 / 0AF11 | 0AF03 / 0AF12 | 0AF04 / 0AF13 | 0AF05 |
|------------------------------|---------------------|---------------------|---------------------|---------------------|----------|
| For position switch | 3SE51/52 | 3SE51/52 | 3SE51/52 | 3SE51/52 | 3SE5132 |
| According to standard | EN 50047 / EN 50041 | EN 50047 / EN 50041 | EN 50047 / EN 50041 | EN 50047 / EN 50041 | EN 50041 |
| Actuator head | Plastic/metal | | | | Plastic |
| Metal lever | ✓ | ✓ | — | — | ✓ |
| Stainless steel lever | — | — | ✓ | ✓ | — |
| Plastic roller | ✓ | — | ✓ | — | ✓ |
| Stainless steel roller | — | ✓ | — | ✓ | — |
| Roller Ø | 22 mm / 13 mm | 22 mm / 13 mm | 22 mm / 13 mm | 22 mm / 13 mm | 22 mm |
| Approach direction only from | Below | Below | Below | Below | Below |
| Approach velocity v_{max} | 1 m/s | 2.5 m/s | 1 m/s | 2.5 m/s | 1 m/s |

Because the actuator is equipped with a plastic or stainless steel roller, it is especially well-suited for actuating elements made of finely-ground steel in the form of cams, bars, or cam discs without additional lubrication.

The angular roller levers are distinguished by a very long mechanical service life.

4.3.6.6 Spring rod



3SE5000-0AR01

| |
|--|
| ⚠ WARNING |
| Risk of injury or death. |
| Spring rod actuators must not be used for safety circuits. |

Note

The spring rod is only suitable for switches with snap-action contacts.







| 3SE5000- | 0AR01 | 0AR02 | 0AR03 | 0AR04 |
|-----------------------------|---|---------------------|---------------------|---------------------|
| For position switch | 3SE51/52 | 3SE51/52 | 3SE51/52 | 3SE51/52 |
| According to standard | — | — | — | — |
| Actuator head | Plastic | Plastic | Plastic | Plastic |
| Stainless steel plunger | — | ✓ | — | — |
| Plastic plunger | ✓ | — | ✓ | ✓ |
| Plunger length | 50 mm | 50 mm | 10 mm | 50 mm |
| Spring length | 50 mm | 50 mm | 23.5 mm | 150 mm |
| Total length | 142.5 mm | 142.5 mm | 76 mm | 242.5 mm |
| Approach direction | From all directions | From all directions | From all directions | From all directions |
| Approach velocity v_{max} | 1 m/s | 1 m/s | 1 m/s | 1 m/s |
| Special features | <ul style="list-style-type: none"> • Only suitable for switches with snap-action contacts • No positive opening operation | | | |

The spring rod is suitable for applications in which the direction of actuation changes constantly.

4.3 Mechanical position switches

4.3.6.7 Part-turn actuators with lever

Because they are available in many different variations, position switches with twist lever and rod lever are all-purpose switches. They are less sensitive to environmental influences than other actuators (for example, oils run past on the side). The arrangement of actuator and shaft seal make twist levers and rod levers especially insensitive to heavy exposure to dirt, grinding dust, or coarse-grained material.

| | | | | |
|--|---|--|---|---|
|  | | | | |
| Actuator heads | | | 3SE5000-0AK00 3SE5000-0AH00 3SE5000-0AJ00 | |
| + | + | + | + | + |
|  |  (No positive opening operation) |  |  (No positive opening operation) |  |
| 3SE5000-0AA0./1./2./3. | 3SE5000-0AA5. | 3SE5000-0AA6. | 3SE5000-0AA8. | 3SE5000-0AT0. |
| Twist lever | Twist lever, adjustable-length | Twist lever, adjustable-length, with pre-drilled holes | Rod lever | Fork lever |

All actuators can be subsequently mounted onto the position switch enclosure or replaced with other actuator variants. In addition, they can be offset in 16x 22.5° increments.

The part-turn actuators offer right, left, or right/left direction of operation by default and can be offset from 10° to 10° on the actuator shaft.

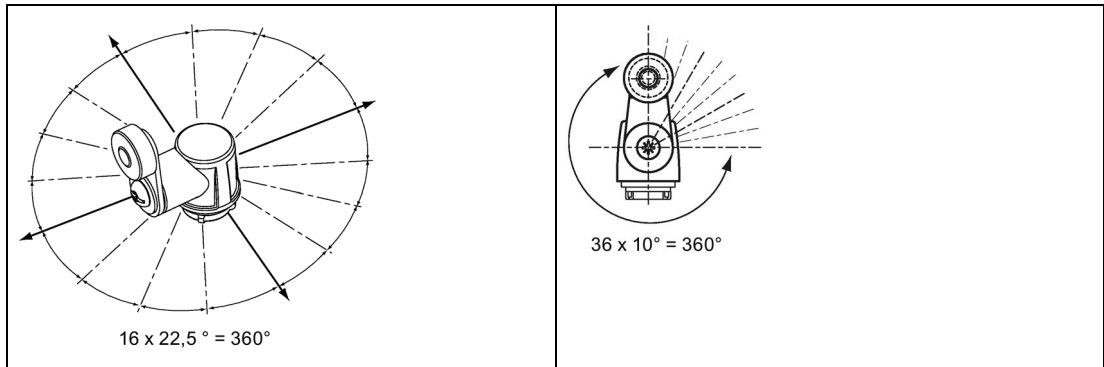

Note

Conversion of actuator head possible.

The actuator head can be converted to right-operating and/or left-operating (see Changing the actuator head (Page 92)).

Special features:

- Different materials of
 - Metal
 - Plastic
 - Stainless steel (important for anti-corrosion protection)
- Different rollers made of
 - Plastic
 - Metal
 - Stainless steel
 - Rubber
- Different roller diameters
- Rollers with ball bearing
- Various lever lengths
- High approach velocity ($v = 1.5 \text{ m/s}$)
- Many possible approaches
- Insensitive to
 - Oil
 - Grinding dust
 - Dirt
 - Coarse-grained material
- Twist lever (maximum approach angle = maximum trailing angle)
- The rod lever or adjustable-length twist lever is intended for cases where an actuating element with approach angle and trailing angle is not possible for technological reasons (e.g., packages, bottles, etc.)
- 10 ° offset of part-turn actuators possible

4.3 Mechanical position switches

4.3.6.8 Twist lever



3SE5000-0AA2./3. - Straight lever



3SE5000-0AA0./1. - Offset lever

| 3SE5000- | 0AA01 / 0AA15 / 0AA24 | 0AA21 | 0AA03 / 0AA23 | 0AA05 / 0AA25 | 0AA07 | 0AA24 / 0AA26 |
|------------------------------------|---|---|---------------------|---------------------|--|--|
| For position switch | 3SE51 / 3SE51 / 3SE51/52 | 3SE52 | 3SE51 / 3SE52 | 3SE51 / 3SE52 | 3SE51 | 3SE51/52 |
| According to standard | EN 50041 | EN 50047 | EN 50041 / EN 50047 | EN 50041 / EN 50047 | EN 50041 | EN 50041 |
| Metal lever | ✓ | ✓ | ✓ | ✓ | ✓ | ✓ |
| Stainless steel lever | — | — | — | — | — | — |
| Lever length | 27 mm / 35 mm / 30 mm | 21 mm | 27 mm / 21 mm | 27 mm / 21 mm | 27 mm | 30 mm |
| Plastic roller | ✓ | ✓ | — | ✓ | ✓ | ✓ |
| Stainless steel roller | — | — | — | — | — | — |
| Ball bearing roller | — | — | ✓ | — | — | — |
| Rubber roller | — | — | — | — | — | — |
| Roller Ø | 19 mm | 19 mm | 19 mm | 30 mm | 50 mm | 19 mm/ 30 mm |
| Approach direction | From left and right | | | | | |
| Approach velocity V _{max} | 1.5 m/s | 1.5 m/s | 1.5 m/s | 1.5 m/s | 1.5 m/s | 1.5 m/s |
| Special features | 3SE5000-0AA01-1AJ0 functional at -40 °C | 3SE5000-0AA21-1AJ0 functional at -40 °C | — | — | 3SE5000-0AA31-1AJ00 functional at -40 °C | Roller mounted inversely ¹⁾ |

1) Roller rotated 180°, mounted on the rear of the lever

| 3SE5000- | 0AA08 | 0AA02 / 0AA22 | 0AA11 | 0AA12 / 0AA31 / 0AA32 | 0AA04 |
|------------------------------|---------------------|---------------------|---|--------------------------------|----------|
| For position switch | 3SE51 | 3SE51 / 3SE52 | 3SE51 | 3SE51 / 3SE52 / 3SE52 | 3SE51 |
| According to standard | EN 50041 | EN 50041 / EN 50047 | EN 50041 | EN 50041 / EN 50047 / EN 50047 | EN 50041 |
| Metal lever | ✓ | ✓ | — | — | ✓ |
| Stainless steel lever | — | — | ✓ | ✓ | — |
| Lever length | 27 mm | 27 mm / 21 mm | 27 mm | 27 mm / 21 mm / 21 mm | 27 mm |
| Plastic roller | — | — | ✓ | — | 2x |
| Stainless steel roller | — | ✓ | — | ✓ | — |
| Ball bearing roller | — | — | — | — | — |
| Rubber roller | ✓ | — | — | — | — |
| Roller Ø | 50 mm | 19 mm | 19 mm | 19 mm | 19 mm |
| Approach direction | From left and right | | | | |
| Approach velocity v_{\max} | 1.5 m/s | 1.5 m/s | 1.5 m/s | 1.5 m/s | 1.5 m/s |
| Special features | — | — | 3SE5000-0AA11-1AJ0 functional at -40 °C | — | — |

Twist lever (maximum approach angle = maximum trailing angle)

4.3 Mechanical position switches

4.3.6.9 Adjustable-length twist lever with oblong hole

Because they are available in many different variations, position switches with adjustable-length twist levers are all-purpose switches. They are less sensitive to environmental influences than other actuators (for example, oils run past on the side). The arrangement of actuator and shaft seal make twist levers especially insensitive to heavy exposure to dirt, grinding dust, or coarse-grained material.



3SE5000-0AA5.

| 3SE5000- | 0AA50 | 0AA51 | 0AA52 | 0AA53 | 0AA55 | 0AA56 | 0AA57 | 0AA58 |
|-----------------------------|---------------------|---------|----------------------------|----------------------------|---------|---------|---------|---------|
| For position switch | 3SE51/52 | | | | | | | |
| According to standard | EN 50047 / EN 50041 | | | | | | | |
| Stainless steel lever | — | — | ✓ | ✓ | — | — | — | — |
| Metal lever | ✓ | ✓ | — | — | ✓ | ✓ | ✓ | ✓ |
| Lever length | 100 mm | 100 mm | 100 mm | 100 mm | 100 mm | 146 mm | 100 mm | 100 mm |
| Stainless steel roller | — | ✓ | — | ✓ | — | — | — | — |
| Plastic roller | ✓ | — | ✓ | — | ✓ | ✓ | ✓ | — |
| Rubber roller | — | — | — | — | — | — | — | ✓ |
| Roller Ø | 19 mm | 19 mm | 19 mm | 19 mm | 30 mm | 22 mm | 50 mm | 50 mm |
| Approach direction from | left and right | | | | | | | |
| Approach velocity v_{max} | 1.5 m/s | 1.5 m/s | 1.5 m/s | 1.5 m/s | 1.5 m/s | 1.5 m/s | 1.5 m/s | 1.5 m/s |
| Special features | — | — | With stainless steel clamp | With stainless steel clamp | — | — | — | — |

! CAUTION

Switch function can be impaired.

The actuators with adjustable-length twist lever without pre-drilled holes are not suitable for safety circuits.

The adjustable-length twist lever is intended for cases where an actuating element with approach angle and trailing angle is not possible for technological reasons (e.g., packages, bottles, etc.).

4.3.6.10 Adjustable-length twist lever with pre-drilled holes

Because they are available in many different variations, position switches with adjustable-length twist levers are all-purpose switches. They are less sensitive to environmental influences than other actuators (for example, oils run past on the side). The arrangement of actuator and shaft seal make twist levers especially insensitive to heavy exposure to dirt, grinding dust, or coarse-grained material.



3SE5000-0AA6.

| 3SE5000- | 0AA60 | 0AA61 | 0AA62 / 0AA64 | 0AA63 | 0AA67 | 0AA68 |
|--------------------------------|---|----------|--|----------------------------|----------|----------|
| For position switch | 3SE51/52 | 3SE51/52 | 3SE51/52 | 3SE51/52 | 3SE51/52 | 3SE51/52 |
| According to standard | EN 50047 / EN 50041 | | | | | |
| Stainless steel lever | — | — | ✓ | ✓ | — | — |
| Metal lever | ✓ | ✓ | — | — | ✓ | ✓ |
| Lever length | 100 mm | 100 mm | 100 mm | 100 mm | 100 mm | 100 mm |
| Stainless steel roller | — | ✓ | — | ✓ | — | — |
| Plastic roller | ✓ | — | ✓ | — | ✓ | — |
| Rubber roller | — | — | — | — | — | ✓ |
| Roller Ø | 19 mm | 19 mm | 19 mm | 19 mm | 50 mm | 50 mm |
| Approach direction from | left and right | | | | | |
| Approach velocity v_{max} | 1.5 m/s | 1.5 m/s | 1.5 m/s | 1.5 m/s | 1.5 m/s | 1.5 m/s |
| Special features | 3SE5000-0AA60-1AJ0 functional at -40 °C | — | 3SE5000-0AA62-1AJ0 functional at -40 °C | With stainless steel clamp | — | — |
| | — | — | 3SE5000-0AA62 with stainless steel clamp | — | — | — |

The adjustable-length twist lever is intended for cases where an actuating element with approach angle and trailing angle is not possible for technological reasons (e.g., packages, bottles, etc.).

4.3 Mechanical position switches

4.3.6.11 Rod lever

Because they are available in many different variations, position switches with rod levers are all-purpose switches. They are less sensitive to environmental influences than other actuators (for example, oils run past on the side). The arrangement of actuator and shaft seal make rod levers especially insensitive to heavy exposure to dirt, grinding dust, or coarse-grained material.



3SE5000-0AA80



3SE5000-0AA81



3SE5000-0AA82

| 3SE5000- | 0AA80 | 0AA81 | 0AA82 | 0AA83 |
|-----------------------------|---------------------|---------------------|---------------------|---------------------|
| For position switch | 3SE51 / 3SE52 | 3SE51 / 3SE52 | 3SE51 / 3SE52 | 3SE51 / 3SE52 |
| According to standard | EN 50041 / EN 50047 | EN 50041 / EN 50047 | EN 50041 / EN 50047 | EN 50041 / EN 50047 |
| Aluminum rod | ✓ | — | — | — |
| Plastic rod | — | — | ✓ | ✓ |
| Spring rod | — | ✓ | — | — |
| Length | 200 mm | 200 mm | 200 mm | 330 mm |
| Rod Ø | 6 mm | 6 mm | 6 mm | 6 mm |
| Approach direction from | left and right | left and right | left and right | left and right |
| Approach velocity v_{max} | 1.5 m/s | 1.5 m/s | 1.5 m/s | 1.5 m/s |
| Special features | With clamp | With clamp | With clamp | With clamp |

| |
|--|
|  CAUTION |
| <p>Switch function can be impaired.</p> <p>The actuator with rod lever is not suitable for safety circuits.</p> |

The rod lever is intended for cases where an actuating element with approach angle and trailing angle is not possible for technological reasons (e.g., packages, bottles, etc.).

4.3.6.12 Fork lever



3SE5000-0AT0.

| 3SE5000- | 0AT01 | 0AT02 | 0AT03 | 0AT04 |
|------------------------------|---|---------------|---------------|---------------|
| For position switch | 3SE51 | 3SE51 | 3SE51 | 3SE51 |
| For actuator head | 3SE5000-0AT10 | 3SE5000-0AT10 | 3SE5000-0AT10 | 3SE5000-0AT10 |
| According to standard | EN 50041 | EN 50041 | EN 50041 | EN 50041 |
| 2 x metal lever | ✓ | ✓ | — | — |
| 2 x stainless steel lever | — | — | ✓ | ✓ |
| Plastic roller | ✓ | — | — | ✓ |
| Stainless steel roller | — | ✓ | ✓ | — |
| Roller \varnothing | 19 mm | 19 mm | 19 mm | 19 mm |
| Approach direction from | left and right | | | |
| Approach velocity v_{\max} | 1.5 m/s | 1.5 m/s | 1.5 m/s | 1.5 m/s |
| Special features | <ul style="list-style-type: none"> • Can be operated in two directions • Latching actuator • For reciprocating movements | | | |

Note

The fork lever latches after actuation and must be reset.

4.3 Mechanical position switches

4.3.7 Combinations

Any enclosure can be combined with any available actuator.

The following contact blocks can be interchanged:

| | 2-pin | 3-pin | 3-pin with make-before-break |
|--|-------------|----------------------------|------------------------------|
| • With snap-action function | 1 NO + 1 NC | 1 NO + 2 NC | — |
| • With slow-action function | 1 NO + 1 NC | 1 NO + 2 NC 2 NO + 1 NC | — |
| • With slow-action function with make-before-break | — | — | 1 NO + 2 NC |

Contact blocks

- Slow-action contacts (1 NO + 1 NC), (1 NO + 2 NC), (2 NO + 1 NC)
- Slow-action contacts with make-before-break
- Snap-action contacts (1 NO + 1 NC), + (1 NO + 2 NC)
 - 2 x 2 mm operating distance (1 NO + 1 NC)
 - Short stroke (1 NO + 1 NC)
The short-stroke element (1 NO + 1 NC) improves the switching accuracy through a reduced actuator travel.
 - Hard-gold-plated contacts (used for applications with low currents, low switching frequency, corrosive vapors)

Covers

The covers can be replaced.

Cover colors

The standard cover color is turquoise.

Yellow covers are also available in order to make the safety switch stand out visually.

Plastic enclosures can only be used with plastic covers and metal enclosures only with metal covers.

4.3.8 Connection

4.3.8.1 Contact blocks

Replaceable 2-pin and 3-pin contact blocks for all enclosure sizes.



The 3-pin contact block (1 normally open contact + 2 normally closed contacts or 2 normally open contacts + 1 normally closed contact) in three contact versions (snap-action, slow-action, and slow-action with make-before-break) is available for all enclosure types. It offers additional safety through redundant switch-off (2 normally closed contacts) with simultaneous signaling (1 normally open contact). It requires the same installation space as the 2-pin contact block.

Connection with stranded and finely stranded cable

CAUTION

There is a risk of injury if no end sleeve is used.

For stranded and finely stranded cables, use end sleeves to prevent splicing open of connecting wires when inserting them in terminals.

Pay attention to the notes on ferrules in DIN 46 228, Part 1.

NOTICE

Incorrect wire stripping causes a risk of short-circuits.

The stripped length must not exceed 7 mm.

4.3 Mechanical position switches

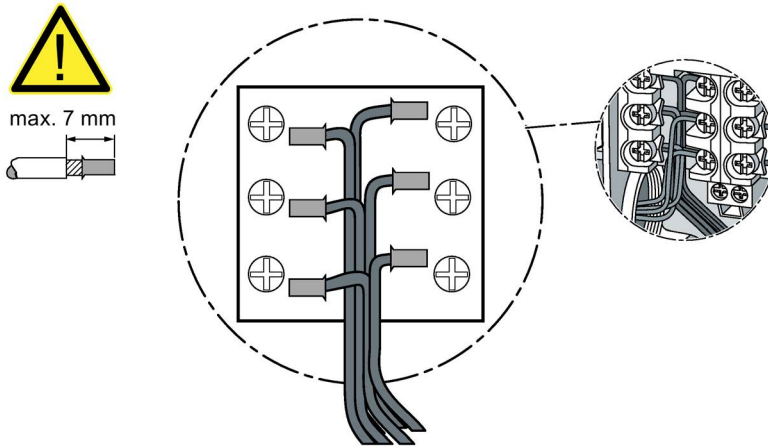

Connection with solid cable

NOTICE
Incorrect wire stripping causes a risk of short-circuits.
The stripped length must not exceed 7 mm when connecting with solid cable.

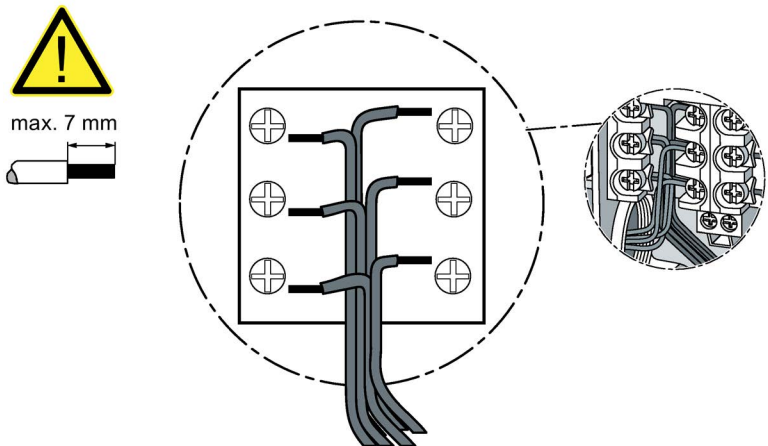

4.3.8.2 Quick-connect system

The quick-connect system is used with the 31 mm-wide plastic enclosure.



These position switches have an option for easy and fast wiring. The connecting cable is first connected to the contact block terminals and then routed through a slot in the cable gland opening.

4.3.8.3 Plug connection

There are various connectors for the device connection:

- Connector M12, 4-pin, plastic
- Connector M12, 5-pin, plastic
- Connector, 6-pin + PE, plastic
- Connector M12, 8-pin, metal

Some of these are available as complete switch variants and some as accessories (Page 130).

4.3 Mechanical position switches

4.3.8.4 Device connector: pin assignment

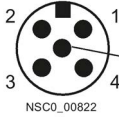
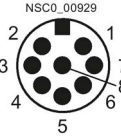
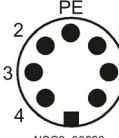
| | |
|---|---|
| Plug connector M12, 4-pin 3SY3127 | Plug connector M12, 5-pin 3SY3128 |
|  |  |
| Plug connector M12, 8-pin 3SY3134 | Plug connector, 6-pin + PE Standard DIN 43651 (EN 175201-804) 3SY3131 |
|  |  |

| 3SE5..4-.....- | 1AC4 | 1AC5 | 1AE0 | 1AE1 | 1AF3 | 1AF3 | 1AD4 | 1AD4 |
|--------------------------------------|-------------|-------------|---------|---------|-----------------------|-----------------------|-----------------------|-----------------------|
| Plug connector M12, 4-, 5-, or 8-pin | 3SY3127 | 3SY3128 | 3SY3127 | 3SY3128 | 3SY3128 (snap action) | 3SY3128 (slow action) | 3SY3134 (snap action) | 3SY3134 (slow action) |
| Contacts | 1 NO + 1 NC | 1 NO + 1 NC | 2 NC | 2 NC | 1 NO + 1 NC | 1 NO + 1 NC | 1 NO + 2 NC | 1 NO + 2 NC |
| LED | — | — | — | — | 2 LED | 2 LED | 2 LED | 2 LED |
| Pin 1 | 21 | 21 | 21 | 21 | 21 | 21 | 21 | 21 |
| Pin 2 | 22 | 22 | 22 | 22 | 22 | 22 | 22 | 22 |
| Pin 3 | 13 | 13 | 31 | 31 | 13 / LED gn | 14 / LED gn | 13 / LED gn | 14 / LED gn |
| Pin 4 | 14 | 14 | 32 | 32 | 14 / LED ye | 13 / LED ye | 14 / LED ye | 13 / LED ye |
| Pin 5 | — | PE | — | PE | Ground LED | Ground LED | 31 | 31 |
| Pin 6 | — | — | — | — | — | — | 32 | 32 |
| Pin 7 | — | — | — | — | — | — | Ground LED | Ground LED |
| Pin 8 | — | — | — | — | — | — | PE | PE |
| PE | — | — | — | — | — | — | — | — |

gn = green
ye = yellow

| 3SE5..5-.....- | 1AD0 | 1AD1 | 1AD2 | 1AD2 | 1AF2 | 1AF2 |
|-------------------------------|-------------|-------------|--------------------------|--------------------------|--------------------------|--------------------------|
| Plug connector, 6-pin + PE | 3SY3131 | 3SY3131 | 3SY3131 (snap action) | 3SY3131 (slow action) | 3SY3131 (snap action) | 3SY3131 (slow action) |
| Contacts | 1 NO + 1 NC | 1 NO + 2 NC | 1 NO + 2 NC | 1 NO + 2 NC | 1 NO + 1 NC | 1 NO + 1 NC |
| LED | — | — | 2 LED | 2 LED | 2 LED | 2 LED |
| Pin 1 | 21 | 21 | 21 | 21 | 21 | 21 |
| Pin 2 | 22 | 22 | 22 | 22 | 22 | 22 |
| Pin 3 | 13 | 13 | 31 | 31 | 13 / LED gn | 14 / LED gn |
| Pin 4 | 14 | 14 | 32 | 32 | 14 / LED ye | 13 / LED ye |
| Pin 5 | — | 31 | 13 / LED gn | 14 / LED gn | — | — |
| Pin 6 | — | 32 | Ground LED | Ground LED | Ground LED | Ground LED |
| Pin 7 | — | — | — | — | — | — |
| Pin 8 | — | — | — | — | — | — |
| PE | ✓ | ✓ | ✓ | ✓ | ✓ | ✓ |

gn = green

ye = yellow

✓ = connected

4.3.9 Notes on installation

4.3.9.1 Installation instructions for twist levers

Installation of twist levers

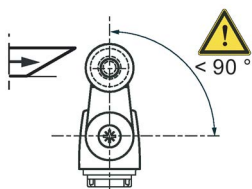

Note

Maximum actuating angle of 90 degrees.

Please note when installing a twist lever that the maximum permitted actuating angle is 90 degrees.

4.3 Mechanical position switches

4.3.9.2 Changing the actuator head

The actuators can be interchanged.

Possible changes to the method of actuation

- Every actuator can be replaced with any other actuator variant.
- Every actuator can be offset by 22.5° (depending on the actuator adjustment and the enclosure type).
- The twist lever can be offset from 10° to 10° on the actuator shaft, and can be repositioned 180°.

Procedure for changing the direction of operation and replacing the actuator head

1. Unscrew the enclosure cover (1).
2. Rotate the locking plate (2) to the right.

Note

The spring is preloaded and may be lost when changing the actuator head. If this happens the switch will no longer function in the case of part-turn actuators. Keep a firm hold on the actuator head while removing it.

3. Remove the actuator head (3).
4. Insert the new actuator head (3) until it reaches the endstop.
5. Rotate the locking plate (2) to the left.
6. Screw on the enclosure cover (1).
 - **Part-turn actuator 3SE5000-0AH00/AK00/AJ00** is left- and right-operating (factory configuration) (4.1)
 - **Adjusting the actuator head to be left-operating or right-operating only**
Actuating plunger (4) rotated 90° to the left = left-operating (4.2).
Actuating plunger (4) rotated 90° to the right = right-operating (4.3).

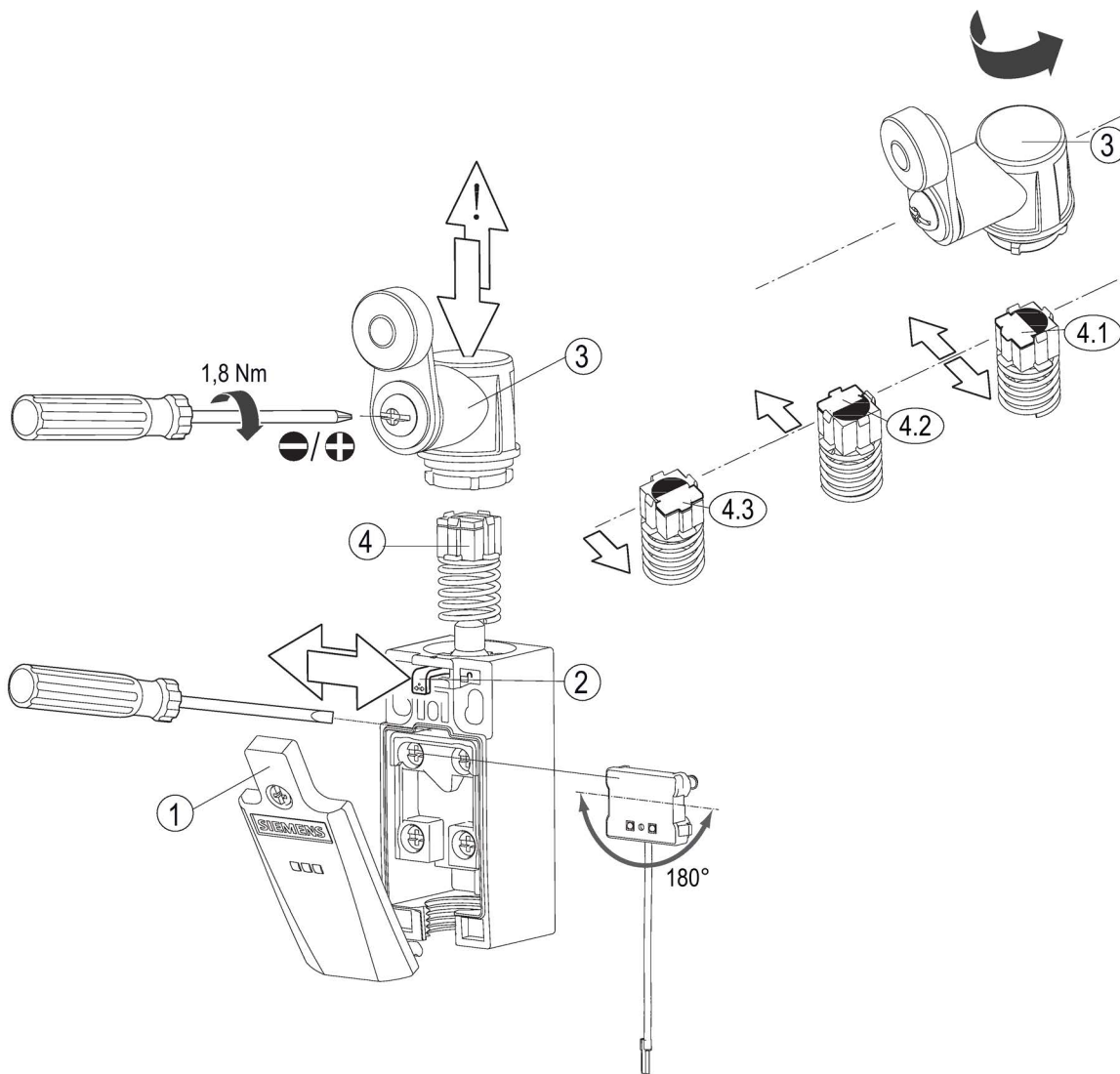

Figure 4-3 Changing the actuator head (example: part-turn actuator)

4.3 Mechanical position switches

4.3.10 Technical data for mechanical position switches

4.3.10.1 Technical data in Siemens Industry Online Support

Technical data sheet

You can also find the technical data of the product at Siemens Industry Online Support (<https://support.industry.siemens.com/cs/ww/en/ps/>).

1. Enter the full article number of the desired device in the "Product" field, and confirm with the Enter key.
2. Click the "Technical data link."

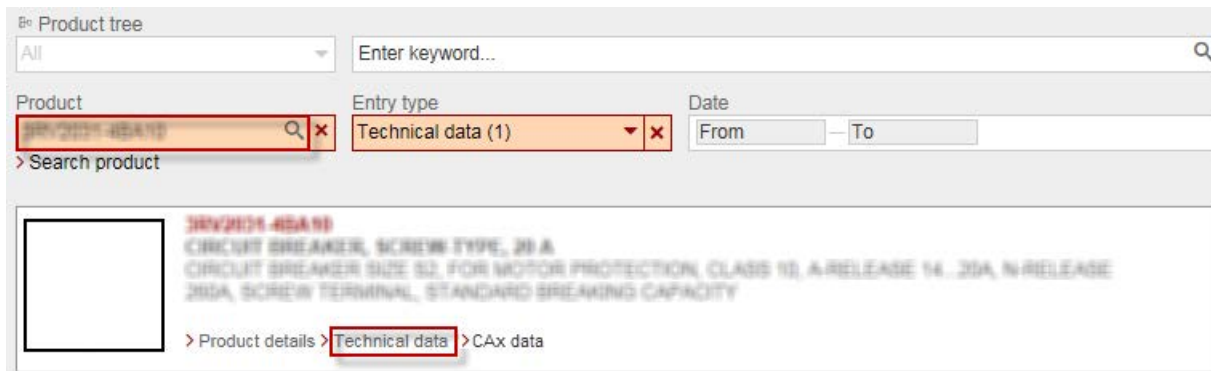

4.3.11 Dimension drawings and operating travel diagrams for mechanical position switches

Basic switch

| | | |
|--|--|--|
| <p>Enclosure width 31 mm, EN 50047, with connecting thread M20 × 1.5 3SE5232 / 3SE5212</p> | <p>Enclosure width 31 mm, EN 50047, Rear panel with mounting holes 3SE5232/212</p> | <p>Enclosure width 31 mm, EN 50047, with plug connector M12 3SE5234/214</p> |
| | | |
| <p>Enclosure width 50 mm, with 2x connecting thread M20 × 1.5 3SE5242</p> | <p>Enclosure width 50 mm, rear panel with mounting holes 3SE5242</p> | <p>Enclosure width 40 mm, EN 50041, with connecting thread M20 × 1.5 3SE5112/132</p> |
| | | |
| <p>Enclosure width 40 mm, EN 50041, with plug connector M12 3SE5114/134</p> | <p>Enclosure width 40 mm, EN 50041, with plug connector 6-pin + PE 3SE5115</p> | <p>Enclosure width 56 mm, with 3x connecting thread M20 × 1.5 3SE5122</p> |
| | | |

4.3 Mechanical position switches

XL enclosure, enclosure width 56 mm, with 3x connecting thread M20 × 1.5
3SE5162

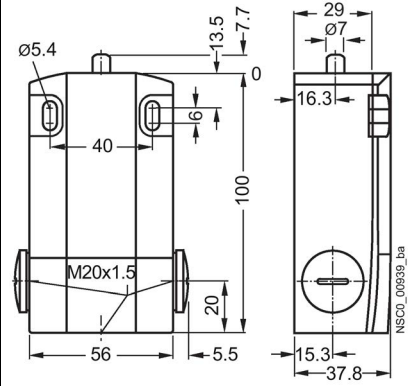

The XL enclosure can only be combined with the following actuator heads:

- 3SE5000-..B..
- 3SE5000-..C..
- 3SE5000-..D..
- 3SE5000-..E..
- 3SE5000-..F..
- 3SE5000-..H..

Plain plunger 3SE5000-0AB01

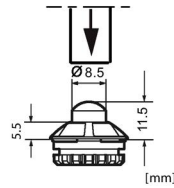

$v \leq 1.5$ m/s (maximum actuating speed)

$F \geq 20$ N (minimum force demand in actuation direction)

| Slow-action contacts | | | With make-before-break |
|---|--|--|--|
| <p>1 NO + 1 NC</p> <p>Code number 11</p> | <p>1 NO + 2 NC</p> <p>Code number 12</p> | <p>2 NO + 1 NC</p> <p>Code number 21</p> | <p>1 NO + 2 NC</p> <p>Code number 12</p> |
| Actuation in travel direction | | | |
| <p>3SE5...-0BB01</p> | <p>3SE5...-0KB01</p> | <p>3SE51...-0PB01</p> | <p>3SE51...-0MB01 ¹⁾</p> |
| <p>¹⁾ Cannot be ordered as complete unit</p> | | | |

4.3 Mechanical position switches

| Snap-action contacts | | |
|---|--|--|
| <p>1 NO + 1 NC</p> <p>Code number 11</p> | <p>1 NO + 1 NC</p> <p>Code number 11</p> | <p>1 NO + 2 NC</p> <p>Code number 12</p> |
| Actuation in travel direction | | |
| <p>3SE5...-0CB01 3SE5...-0GB01 ^{1) 2)} 3SE5...-0HB01 ¹⁾</p> | <p>3SE52..-0NB01 ¹⁾</p> <p>Short stroke</p> | <p>3SE5...-0LB01</p> |
| <p>¹⁾ Cannot be ordered as complete unit ²⁾ Operating distance 2 x 2 mm</p> | | |

- ⊕ Positive opening operation according to EN 60947-5-1
- Direction of actuation
- Contact element closed
- Contact element open
- ≤ Maximum actuator travel

Rounded plunger 3SE5000-0AC02 / -0AC03

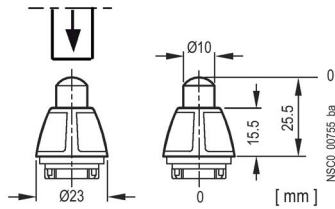

$v \leq 1.5 \text{ m/s}$ (maximum actuating speed)

$F \geq 20 \text{ N}$ (minimum force demand in actuation direction)

| Slow-action contacts | | | With make-before-break | | | | |
|--|-----------------------------------|-----------------------------------|-----------------------------------|------------|------------|--------------------------|--------------------------|
| 1 NO + 1 NC Code number 11 | 1 NO + 2 NC Code number 12 | 2 NO + 1 NC Code number 21 | 1 NO + 2 NC Code number 12 | | | | |
| Actuation in travel direction | | | | | | | |
| 3SE51.. | | | | | | | |
| -0BC02 | -0BC03 | -0KC02 | -0KC03 | -0PC02 | -0PC03 | -0MC02 ¹⁾ | -0MC03 ¹⁾ |
| ¹⁾ Cannot be ordered as complete unit | | | | | | | |

4.3 Mechanical position switches

| Snap-action contacts | | | | | |
|--|------------|-----------------------------------|--------------------------|-----------------------------------|------------|
| 1 NO + 1 NC Code number 11 | | 1 NO + 1 NC Code number 11 | | 1 NO + 2 NC Code number 12 | |
| Actuation in travel direction | | | | | |
| 3SE51.. | | | | | |
| -0CC02 | -0CC03 | -0NC02 ¹⁾ | -0NC03 ¹⁾ | -0LC02 | -0LC03 |
| ¹⁾ Cannot be ordered as complete unit | | | | | |

- ⊕ Positive opening operation according to EN 60947-5-1
- Direction of actuation
- Contact element closed
- Contact element open
- ≤ Maximum actuator travel

Rounded plunger EN 50047 3SE52...-..C05

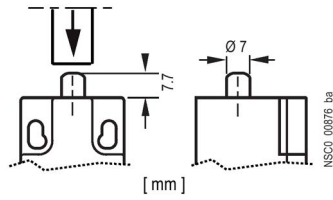

$v \leq 1.5$ m/s (maximum actuating speed)

$F \geq 20$ N (minimum force demand in actuation direction)

| Slow-action contacts | | | With make-before-break |
|--|--|--|--|
| <p>1 NO + 1 NC</p> <p>Code number 11</p> | <p>1 NO + 2 NC</p> <p>Code number 12</p> | <p>2 NO + 1 NC</p> <p>Code number 21</p> | <p>1 NO + 2 NC</p> <p>Code number 12</p> |
| Actuation in travel direction | | | |
| <p>3SE52...-BC05</p> | <p>3SE52...-KC05</p> | <p>3SE52...-PC05</p> | <p>3SE52...-MC05</p> |

4.3 Mechanical position switches

| Snap-action contacts | | | |
|--|--|--|--|
| <p>1 NO + 1 NC</p> <p>Code number 11</p> | <p>1 NO + 1 NC</p> <p>Code number 11</p> | <p>1 NO + 1 NC</p> <p>Code number 11</p> | <p>1 NO + 2 NC</p> <p>Code number 12</p> |
| Actuation in travel direction | | | |
| <p>3SE52..-CC05 3SE52..-HC05</p> | <p>3SE52..-FC05</p> <p>Short stroke integrated</p> | <p>3SE52..-GC05</p> <p>Operating distance 2 x 2 mm</p> | <p>3SE52..-LC05</p> |

- ⊕ Positive opening operation according to EN 60947-5-1
- Direction of actuation
- Contact element closed
- Contact element open
- ≤ Maximum actuator travel

Roller plunger 3SE5000-0AD02 / -0AD05 / -0AD06

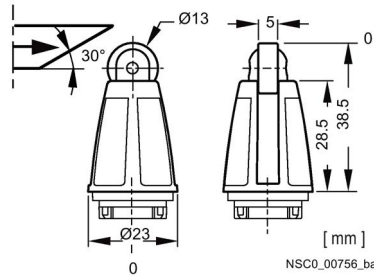

v ≤ 1 m/s (maximum actuating speed)

F ≥ 20 N (minimum force demand in actuation direction)

| Slow-action contacts | | | With make-before-break |
|---|--|--|--|
| <p>1 NO + 1 NC</p> <p>Code number 11</p> | <p>1 NO + 2 NC</p> <p>Code number 12</p> | <p>2 NO + 1 NC</p> <p>Code number 21</p> | <p>1 NO + 2 NC</p> <p>Code number 12</p> |
| Lateral actuation | | | |
| <p>3SE51...-0BD02</p> | <p>3SE51...-0KD02</p> | <p>3SE51...-0PD02 ¹⁾</p> | <p>3SE51...-0MD02 ¹⁾</p> |
| <p>3SE51...-0BD05 3SE51...-0BD06 ¹⁾</p> | <p>3SE51...-0KD05</p> | <p>3SE51...-0PD05 3SE51...-0PD06 ¹⁾</p> | <p>3SE51...-0MD05/06 ¹⁾</p> |
| | <p>3SE51...-0KD06 ¹⁾</p> | <p>3SE51...-0PD06 ¹⁾</p> | |
| <p>¹⁾ Cannot be ordered as complete unit</p> | | | |

4.3 Mechanical position switches

| Snap-action contacts | | |
|---|---|--|
| <p>1 NO + 1 NC</p> <p>Code number 11</p> | <p>1 NO + 1 NC</p> <p>Code number 11</p> | <p>1 NO + 2 NC</p> <p>Code number 12</p> |
| Lateral actuation | | |
| <p>3SE51..-0CD02</p> | <p>3SE51..-0ND02 ¹⁾</p> <p>Short stroke</p> | <p>3SE51..-0LD02</p> |
| <p>3SE51..-0CD05 3SE51..-0CD06 ¹⁾</p> | <p>3SE51..-0ND05/06 ¹⁾</p> <p>Short stroke</p> | <p>3SE51..-0LD05 3SE51..-0LD06 ¹⁾</p> |
| <p>¹⁾ Cannot be ordered as complete unit</p> | | |

- ⊕ Positive opening operation according to EN 60947-5-1
- Direction of actuation
- Contact element closed
- Contact element open

Roller plunger

3SE5000-0AD03 / 3SE5000-0AD04
Type C

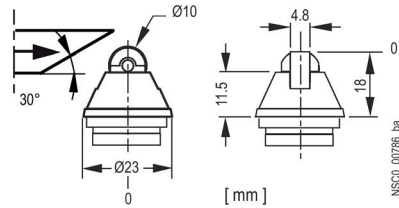

3SE5000-0AD10 / 3SE5000-0AD11
Central fixing

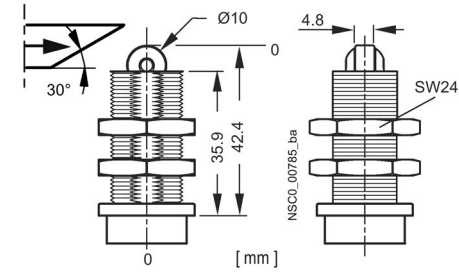



$v \leq 1$ m/s (maximum actuating speed)

$F \geq 20$ N (minimum force demand in actuation direction)

| Slow-action contacts | | | With make-before-break |
|--|--|-----------------------------------|-----------------------------------|
| 1 NO + 1 NC Code number 11 | 1 NO + 2 NC Code number 12 | 2 NO + 1 NC Code number 21 | 1 NO + 2 NC Code number 12 |
| Lateral actuation | | | |
| 3SE52...0BD03 3SE52...0BD04/10/11 ¹⁾ | 3SE52...0KD03/10 3SE52...0KD04/11 ¹⁾ | 3SE52...0PD.. ¹⁾ | 3SE52...0MD.. ¹⁾ |
| ¹⁾ Cannot be ordered as complete unit | | | |

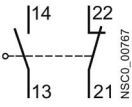
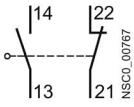
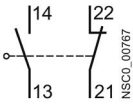
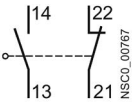
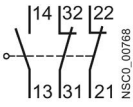
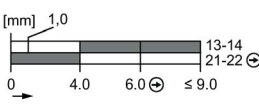
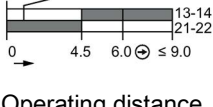
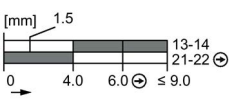
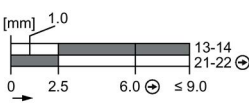
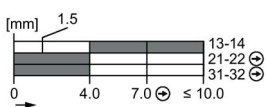
4.3 Mechanical position switches

| Snap-action contacts | | | | |
|--|--|---|--|--|
| <p>1 NO + 1 NC</p>  <p>Code number 11</p> | <p>1 NO + 1 NC</p>  <p>Code number 11</p> | <p>1 NO + 1 NC</p>  <p>Code number 11</p> | <p>1 NO + 1 NC</p>  <p>Code number 11</p> | <p>1 NO + 2 NC</p>  <p>Code number 12</p> |
| Lateral actuation | | | | |
| <p>3SE52...-0CD03/04/10 3SE52...-0CD11 ¹⁾</p>  | <p>3SE52...-0GD.. ¹⁾</p>  <p>Operating distance 2 x 2 mm</p> | <p>3SE52...-0HD03/10 3SE52...-0HD04/11¹⁾</p>  | <p>3SE52...-0FD03 3SE52...-FD04/10/11¹⁾</p>  <p>Short stroke integrated</p> | <p>3SE52...-0LD03 3SE52...-0LD04/10/11 ¹⁾</p>  |
| <p>¹⁾ Cannot be ordered as complete unit</p> | | | | |

- ⊕ Positive opening operation according to EN 60947-5-1
- Direction of actuation
-  Contact element closed
-  Contact element open
- ≤ Maximum actuator travel

Roller lever 3SE5000-0AE0.

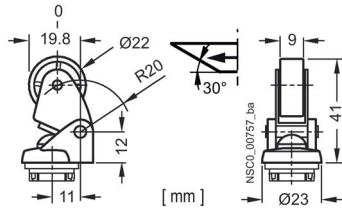

$v \leq 2.5$ m/s (maximum actuating speed)

$F \geq 10$ N (minimum force demand in actuation direction)

| Slow-action contacts | | | With make-before-break |
|---|--|--|--|
| <p>1 NO + 1 NC</p> <p>Code number 11</p> | <p>1 NO + 2 NC</p> <p>Code number 12</p> | <p>2 NO + 1 NC</p> <p>Code number 21</p> | <p>1 NO + 2 NC</p> <p>Code number 12</p> |
| Lateral actuation | | | |
| <p>3SE51...-0BE01/05 3SE51...-0BE02/03/04 ¹⁾</p> | <p>3SE51...-0KE0.</p> | <p>3SE51...-0PE0.</p> | <p>3SE51...-0ME0. ¹⁾</p> |
| <p>¹⁾ Cannot be ordered as complete unit</p> | | | |

4.3 Mechanical position switches

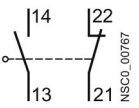
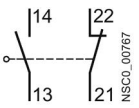
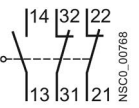
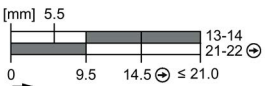
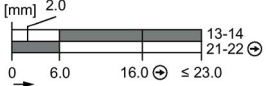
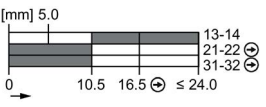
| Snap-action contacts | | |
|---|---|---|
| <p>1 NO + 1 NC</p>  <p>Code number 11</p> | <p>1 NO + 1 NC</p>  <p>Code number 11</p> | <p>1 NO + 2 NC</p>  <p>Code number 12</p> |
| Lateral actuation | | |
| <p>3SE51...-0CE01/02/03/05 3SE51...-0CE04 ¹⁾</p>  | <p>3SE51...-0NE0. ¹⁾</p>  <p>Short stroke</p> | <p>3SE51...-0LE01/05 3SE51...-0LE02/03/04 ¹⁾</p>  |
| <p>¹⁾ Cannot be ordered as complete unit</p> | | |

- ⊕ Positive opening operation according to EN 60947-5-1
- Direction of actuation
- Contact element closed
- Contact element open

Roller lever 3SE5000-0AE1.

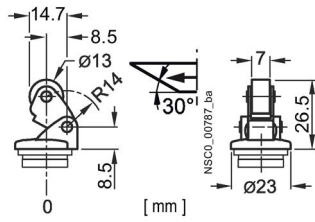

$v \leq 1 \text{ m/s}$ (maximum actuating speed)

$F \geq 10 \text{ N}$ (minimum force demand in actuation direction)

| Slow-action contacts | | | With make-before-break |
|--|--|--|--|
| <p>1 NO + 1 NC</p> <p>Code number 11</p> | <p>1 NO + 2 NC</p> <p>Code number 12</p> | <p>2 NO + 1 NC</p> <p>Code number 21</p> | <p>1 NO + 2 NC</p> <p>Code number 12</p> |
| Lateral actuation | | | |
| <p>3SE52...-0BE10 3SE52...-0BE11/12/13 ¹⁾</p> | <p>3SE52...-0KE10 3SE52...-0KE11/12/13 ¹⁾</p> | <p>3SE52...-0PE1. ¹⁾</p> | <p>3SE52...-0ME1. ¹⁾</p> |
| <p>¹⁾ Cannot be ordered as complete unit</p> | | | |

4.3 Mechanical position switches

| Snap-action contacts | | | |
|--|--|--|--|
| <p>1 NO + 1 NC</p> <p>Code number 11</p> | <p>1 NO + 1 NC</p> <p>Code number 11</p> | <p>1 NO + 1 NC</p> <p>Code number 11</p> | <p>1 NO + 2 NC</p> <p>Code number 12</p> |
| Lateral actuation | | | |
| <p>3SE52...-0CE10/12 3SE52...-0CE11/13 ¹⁾ 3SE52...-0HE10/12 3SE52...-0HE11/13 ¹⁾</p> | <p>3SE52...-0FE1. ¹⁾</p> <p>Short stroke integrated</p> | <p>3SE52...-0GE1. ¹⁾</p> <p>Operating distance 2 x 2 mm</p> | <p>3SE52...-0LE10/12 3SE52...-0LE11/13 ¹⁾</p> |
| <p>¹⁾ Cannot be ordered as complete unit</p> | | | |

- ⊕ Positive opening operation according to EN 60947-5-1
- Direction of actuation
- Contact element closed
- Contact element open

Angular roller lever 3SE5000-0AF0.

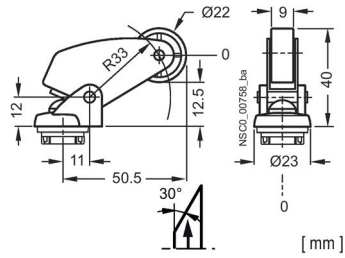

$v \leq 2.5$ m/s (maximum actuating speed)
 $F \geq 10$ N (minimum force demand in actuation direction)

| Slow-action contacts | | | With make-before-break |
|---|--|---|--|
| <p>1 NO + 1 NC</p> <p>Code number 11</p> | <p>1 NO + 2 NC</p> <p>Code number 12</p> | <p>2 NO + 1 NC</p> <p>Code number 21</p> | <p>1 NO + 2 NC</p> <p>Code number 12</p> |
| Actuation in travel direction | | | |
| <p>3SE51..-0BF01/05 3SE51..-0BF02/03/04 ¹⁾</p> | <p>3SE51..-0KF0. ¹⁾</p> | <p>3SE51..-0PF01 3SE51..-0PF02/03/04/05 ¹⁾</p> | <p>3SE51..-0MF0. ¹⁾</p> |
| ¹⁾ Cannot be ordered as complete unit | | | |

4.3 Mechanical position switches

| Snap-action contacts | | |
|---|---|---|
| <p>1 NO + 1 NC</p> <p>Code number 11</p> | <p>1 NO + 1 NC</p> <p>Code number 11</p> | <p>1 NO + 2 NC</p> <p>Code number 12</p> |
| Actuation in travel direction | | |
| <p>3SE51...-0CF01/03/05 3SE51...-0CF02/04 ¹⁾</p> | <p>3SE51...-0NF0. ¹⁾</p> <p>Short stroke</p> | <p>3SE51...-0LF01/05 3SE51...-0LF02/03/04 ¹⁾</p> |
| <p>¹⁾ Cannot be ordered as complete unit</p> | | |

- ⊕ Positive opening operation according to EN 60947-5-1
- Direction of actuation
- Contact element closed
- Contact element open

Angular roller lever 3SE5000-0AF1.

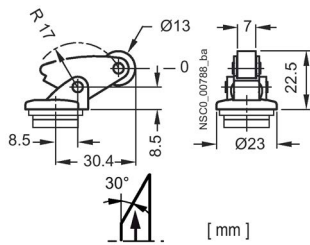

$v \leq 1$ m/s (maximum actuating speed)

$F \geq 10$ N (minimum force demand in actuation direction)

| Slow-action contacts | | | With make-before-break |
|--|--|---|--|
| <p>1 NO + 1 NC</p> <p>Code number 11</p> | <p>1 NO + 2 NC</p> <p>Code number 12</p> | <p>2 NO + 1 NC</p> <p>Code number 21</p> | <p>1 NO + 2 NC</p> <p>Code number 12</p> |
| Actuation in travel direction | | | |
| <p>3SE52..-0BF10 3SE52..-0BF11/12/13 ¹⁾</p> | <p>3SE52..-0KF10 3SE52..-0KF11/12/13 ¹⁾</p> | <p>3SE52..-0PF10/11/12/13 ¹⁾</p> | <p>3SE52..-0MF1. ¹⁾</p> |
| ¹⁾ Cannot be ordered as complete unit | | | |

4.3 Mechanical position switches

| Snap-action contacts | | | | |
|--|--|--|--|--|
| <p>1 NO + 1 NC</p> <p>Code number 11</p> | <p>1 NO + 1 NC</p> <p>Code number 11</p> | <p>1 NO + 1 NC</p> <p>Code number 11</p> | <p>1 NO + 1 NC</p> <p>Code number 11</p> | <p>1 NO + 2 NC</p> <p>Code number 12</p> |
| Actuation in travel direction | | | | |
| <p>3SE52...-0CF10 3SE52...-0CF11/12/13 ¹⁾</p> | <p>3SE52...-OFF1. ¹⁾</p> <p>Short stroke integrated</p> | <p>3SE52...-0GF1. ¹⁾</p> <p>Operating distance 2 x 2 mm</p> | <p>3SE52...-0HF10 3SE52...-0HF11/12/13 ¹⁾</p> | <p>3SE52...-0LF10 3SE52...-0LF11/12/13 ¹⁾</p> |
| <p>¹⁾ Cannot be ordered as complete unit</p> | | | | |

- ⊕ Positive opening operation according to EN 60947-5-1
- Direction of actuation
- Contact element closed
- Contact element open

Spring rod 3SE5000-0AR0.

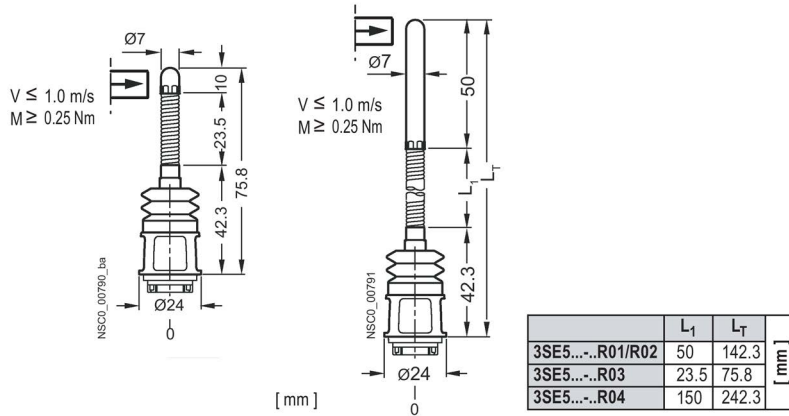

- v ≤ 1 m/s (maximum actuating speed)
- F ≥ 9 N (minimum force demand in actuation direction)
- M ≥ 0.25 Nm (minimum torque in actuation direction)
- No positive opening operation

The spring rods can only be used with snap-action contacts.

| Snap-action contacts | | |
|--|--|--|
| <p>1 NO + 1 NC</p> <p>Code number 11</p> | <p>1 NO + 1 NC</p> <p>Code number 11</p> | <p>1 NO + 2 NC</p> <p>Code number 12</p> |
| Deflection of spring rod | | |
| <p>3SE51...-0CR01 3SE51...-0CR02/03/04 ¹⁾</p> | <p>3SE51...-0NR0. ¹⁾</p> | <p>3SE51...-0LR0. 3SE51...-0LR02/03/04 ¹⁾</p> |
| <p>¹⁾ Cannot be ordered as complete unit</p> | | |

4.3 Mechanical position switches

| Snap-action contacts | | | |
|---|--|---|--|
| <p>1 NO + 1 NC</p> <p>Code number 11</p> | <p>1 NO + 1 NC</p> <p>Code number 11</p> | <p>1 NO + 1 NC</p> <p>Code number 11</p> | <p>1 NO + 2 NC</p> <p>Code number 12</p> |
| Deflection of spring rod | | | |
| <p>3SE52...-0CR0. 3SE52...-0GR0. ¹⁾ 3SE52...-0HR0.</p> | <p>3SE52...-0FR0. ¹⁾</p> <p>Short stroke integrated</p> | <p>3SE52...-0NR0. ¹⁾</p> <p>Short stroke</p> | <p>3SE52...-0LR0.</p> |
| <p>¹⁾ Cannot be ordered as complete unit</p> | | | |

- Direction of actuation
- Contact element closed
- Contact element open

Twist lever

3SE5000-0AH00 / 3SE5000-0AJ00
+ 3SE5000-0AA01 / 02 / 03 / 04 / 11 / 12

3SE5000-0AH00
+ 3SE5000-0AA05 / 06 / 07 / 08

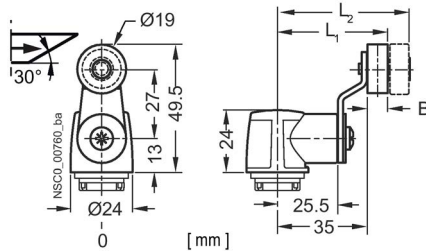

| | | |
|----------------|-----|-----|
| B | 7.8 | 7.2 |
| L ₁ | 43 | — |
| L ₂ | — | 51 |

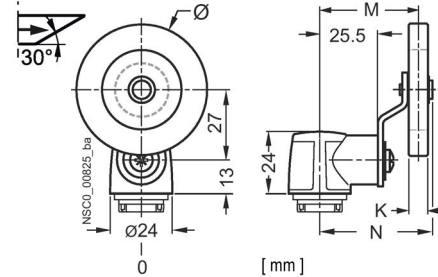

| | | | | |
|---|------|------|------|-----|
| Ø | 30 | 35 | 50 | 50 |
| K | 7.2 | 4.5 | 7.2 | 8.6 |
| M | 39 | 37.5 | 39 | 40 |
| N | 44.5 | 43 | 44.5 | 46 |

v ≤ 1.5 m/s (maximum actuating speed)

M ≥ 0.25 Nm (minimum torque in actuation direction)

Lever adjustable in increments of 10°, maximum deflection 90°

| Slow-action contacts | | | With make-before-break |
|---|--|--|--|
| <p>1 NO + 1 NC</p> <p>Code number 11</p> | <p>1 NO + 2 NC</p> <p>Code number 12</p> | <p>2 NO + 1 NC</p> <p>Code number 21</p> | <p>1 NO + 2 NC</p> <p>Code number 12</p> |
| Deflection in direction of rotation | | | |
| <p>3SE51..-0BH.. 3SE51..-0BJ..</p> | <p>3SE51..-0KH.. 3SE51..-0KJ..</p> | <p>3SE51..-0PH.. 3SE51..-0PJ..</p> | <p>3SE51..-0MH..¹⁾ 3SE51..-0MJ..¹⁾</p> |
| <p>¹⁾ Cannot be ordered as complete unit</p> | | | |

4.3 Mechanical position switches

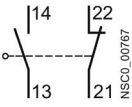
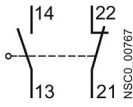
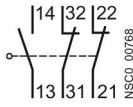
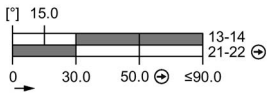
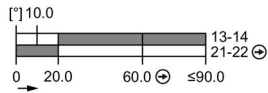
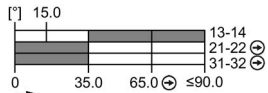
| Snap-action contacts | | |
|--|--|--|
| <p>1 NO + 1 NC</p>  <p>Code number 11</p> | <p>1 NO + 1 NC</p>  <p>Code number 11</p> | <p>1 NO + 2 NC</p>  <p>Code number 12</p> |
| Deflection in direction of rotation | | |
| <p>3SE51...-0CH.. 3SE51...-0CJ..</p>  | <p>3SE51...-0NH.. ¹⁾ 3SE51...-0NJ.. ¹⁾</p> <p>Short stroke</p>  | <p>3SE51...-0LH.. 3SE51...-0LJ..</p>  |
| <p>¹⁾ Cannot be ordered as complete unit</p> | | |

Twist lever 3SE5000-0AK00 / 3SE5000-0AA2. / 3.

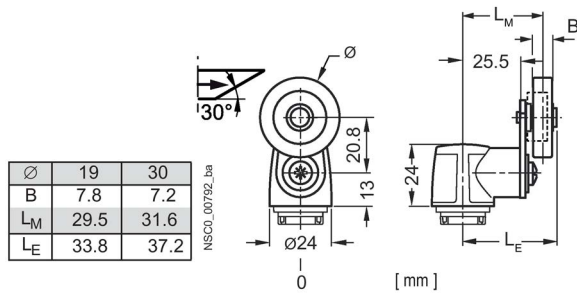





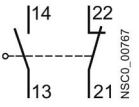
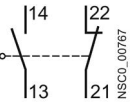
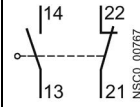
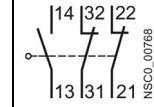
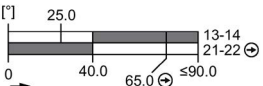
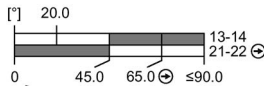
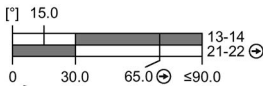
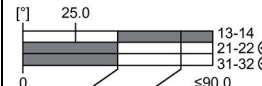

v ≤ 1.5 m/s (maximum actuating speed)

M = 0.25 Nm (minimum torque in actuation direction)

| Slow-action contacts | | | With make-before-break |
|--|--|--|--|
| <p>1 NO + 1 NC</p> <p>Code number 11</p> | <p>1 NO + 2 NC</p> <p>Code number 12</p> | <p>2 NO + 1 NC</p> <p>Code number 21</p> | <p>1 NO + 2 NC</p> <p>Code number 12</p> |
| Deflection in direction of rotation | | | |
| <p>3SE52...-0BK2. 3SE52...-0BK3. ¹⁾</p> | <p>3SE52...-0KK2. 3SE52...-0KK3. ¹⁾</p> | <p>3SE52...-0PK2. ¹⁾ 3SE52...-0PK3. ¹⁾</p> | <p>3SE52...-0MK2. ¹⁾ 3SE52...-0MK3. ¹⁾</p> |
| ¹⁾ Cannot be ordered as complete unit | | | |

4.3 Mechanical position switches

| Snap-action contacts | | | |
|--|---|--|--|
| <p>1 NO + 1 NC</p>  <p>Code number 11</p> | <p>1 NO + 1 NC</p>  <p>Code number 11</p> | <p>1 NO + 1 NC</p>  <p>Code number 11</p> | <p>1 NO + 2 NC</p>  <p>Code number 12</p> |
| Deflection in direction of rotation | | | |
| <p>3SE52...-0CK2. 3SE52...-0HK2.</p>  | <p>3SE52...-0GK2. ¹⁾ 3SE52...-0GK3. ¹⁾</p>  <p>Operating distance 2 x 2 mm</p> | <p>3SE52...-0FK2. ¹⁾ 3SE52...-0FK3. ¹⁾</p>  <p>Short stroke integrated</p> | <p>3SE52...-0LK2. 3SE52...-0LK3. ¹⁾</p>  |
| <p>¹⁾ Cannot be ordered as complete unit</p> | | | |

-  Positive opening operation according to EN 60947-5-1
-  Direction of actuation
-  Contact element closed
-  Contact element open
-  Maximum actuator travel

Adjustable-length twist lever with pre-drilled holes 3SE5000-0AH00 / 3SE5000-0AJ00 + 3SE5000-0AA6.

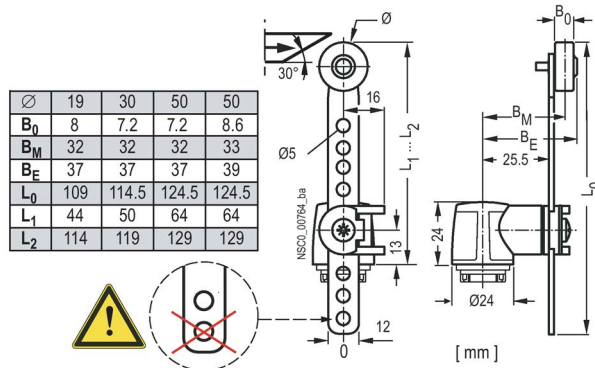

$v_{(met)} \leq 1.5$ m/s (maximum actuating speed)

$v_{(plast)} \leq 1.0$ m/s (maximum actuating speed)

$M \geq 0.25$ Nm (minimum torque in actuation direction)

Note: Do not use the bottommost drill hole.

| Slow-action contacts | | | With make-before-break |
|---|--|--|--|
| <p>1 NO + 1 NC</p> <p>Code number 11</p> | <p>1 NO + 2 NC</p> <p>Code number 12</p> | <p>2 NO + 1 NC</p> <p>Code number 21</p> | <p>1 NO + 2 NC</p> <p>Code number 12</p> |
| Deflection in direction of rotation | | | |
| <p>3SE51...-0BH6. 3SE51...-0BJ6. ¹⁾</p> | <p>3SE51...-0KH6. ¹⁾ 3SE51...-0KJ6. ¹⁾</p> | <p>3SE51...-0PH6. ¹⁾ 3SE51...-0PJ6. ¹⁾</p> | <p>3SE51...-0MH6. ¹⁾ 3SE51...-0MJ6. ¹⁾</p> |
| <p>¹⁾ Cannot be ordered as complete unit</p> | | | |

4.3 Mechanical position switches

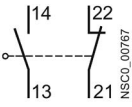
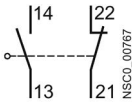
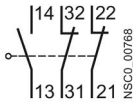
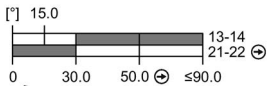
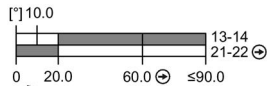
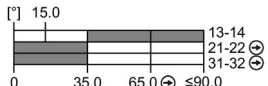
| Snap-action contacts | | |
|--|--|---|
| <p>1 NO + 1 NC</p>  <p>Code number 11</p> | <p>1 NO + 1 NC</p>  <p>Code number 11</p> | <p>1 NO + 2 NC</p>  <p>Code number 12</p> |
| Deflection in direction of rotation | | |
| <p>3SE51...-0CH6. 3SE51...-0CJ6.</p>  | <p>3SE51...-0NH6. ¹⁾ 3SE51...-0NJ6. ¹⁾</p>  <p>Short stroke</p> | <p>3SE51...-0LH6. 3SE51...-0LJ6.</p>  |
| <p>¹⁾ Cannot be ordered as complete unit</p> | | |

Adjustable-length twist lever with pre-drilled holes 3SE5000AK00 + 3SE5000-0AA6.

| Slow-action contacts | | | With make-before-break |
|--|--|--|--|
| <p>1 NO + 1 NC</p> <p>Code number 11</p> | <p>1 NO + 2 NC</p> <p>Code number 12</p> | <p>2 NO + 1 NC</p> <p>Code number 21</p> | <p>1 NO + 2 NC</p> <p>Code number 12</p> |
| Deflection in direction of rotation | | | |
| <p>3SE52..-0BK6. ¹⁾</p> | <p>3SE52..-0KK6.</p> | <p>3SE52..-0PK6. ¹⁾</p> | <p>3SE52..-0MK6. ¹⁾</p> |
| ¹⁾ Cannot be ordered as complete unit | | | |

| Snap-action contacts | | | |
|--|---|--|--|
| <p>1 NO + 1 NC</p> <p>Code number 11</p> | <p>1 NO + 1 NC</p> <p>Code number 11</p> | <p>1 NO + 1 NC</p> <p>Code number 11</p> | <p>1 NO + 2 NC</p> <p>Code number 12</p> |
| Deflection in direction of rotation | | | |
| <p>3SE52..-0CK6. 3SE52..-0HK6.</p> | <p>3SE52..-0GK6. ¹⁾</p> <p>Operating distance 2 x 2 mm</p> | <p>3SE52..-0FK6. ¹⁾ 3SE52..-0NK6. ¹⁾</p> <p>Short stroke</p> | <p>3SE52..-0LK6.</p> |
| ¹⁾ Cannot be ordered as complete unit | | | |

- ⊕ Positive opening operation according to EN 60947-5-1
- Direction of actuation
- Contact element closed
- Contact element open
- ≤ Maximum actuator travel

4.3 Mechanical position switches

Adjustable-length twist lever with oblong hole 3SE5000-0AH00 / 3SE5000-0AJ00 + 3SE5000-0AA5.

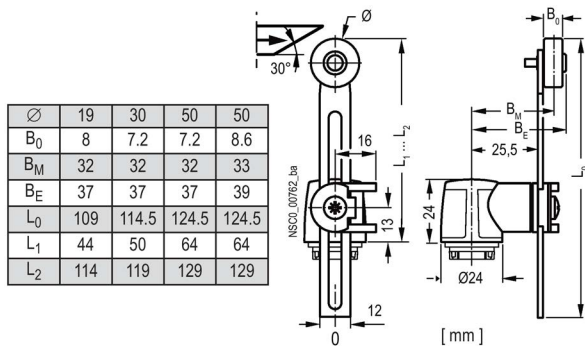

- $v_{(met)} \leq 1.5$ m/s (maximum actuating speed)
- $v_{(plast)} \leq 1.0$ m/s (maximum actuating speed)
- $M \geq 0.25$ Nm (minimum torque in actuation direction)
- Lever adjustable in increments of 10°, maximum deflection 90°
- No positive opening operation

| Slow-action contacts | | | With make-before-break |
|--|--|--|--|
| <p>1 NO + 1 NC</p> <p>Code number 11</p> | <p>1 NO + 2 NC</p> <p>Code number 12</p> | <p>2 NO + 1 NC</p> <p>Code number 21</p> | <p>1 NO + 2 NC</p> <p>Code number 12</p> |
| Deflection in direction of rotation | | | |
| <p>3SE51...-0BH5. 3SE51...-0BJ5. ¹⁾</p> | <p>3SE51...-0KH5. ¹⁾ 3SE51...-0KJ5. ¹⁾</p> | <p>3SE51...-0PH5. ¹⁾ 3SE51...-0PJ5. ¹⁾</p> | <p>3SE51...-0MH5. ¹⁾ 3SE51...-0MJ5. ¹⁾</p> |
| ¹⁾ Cannot be ordered as complete unit | | | |

Adjustable-length twist lever with oblong hole 3SE5000-0AK00 + 3SE5000-0AA5.

| Slow-action contacts | | | With make-before-break |
|--|--|--|--|
| <p>1 NO + 1 NC</p> <p>Code number 11</p> | <p>1 NO + 2 NC</p> <p>Code number 12</p> | <p>2 NO + 1 NC</p> <p>Code number 21</p> | <p>1 NO + 2 NC</p> <p>Code number 12</p> |
| Deflection in direction of rotation | | | |
| <p>3SE52...-0BK5.</p> | <p>3SE51...-0KK5.</p> | <p>3SE51...-0PK5. ¹⁾</p> | <p>3SE51...-0MK5. ¹⁾</p> |
| ¹⁾ Cannot be ordered as complete unit | | | |

| Snap-action contacts | | | |
|--|--|--|--|
| <p>1 NO + 1 NC</p> <p>Code number 11</p> | <p>1 NO + 1 NC</p> <p>Code number 11</p> | <p>1 NO + 1 NC</p> <p>Code number 11</p> | <p>1 NO + 2 NC</p> <p>Code number 12</p> |
| Deflection in direction of rotation | | | |
| <p>3SE52...-0CK5. 3SE52...-0HK5.</p> | <p>3SE52...-0GK5. ¹⁾</p> <p>Operating distance 2 x 2 mm</p> | <p>3SE52...-0FK5. ¹⁾ 3SE52...-0NK5. ¹⁾</p> <p>Short stroke</p> | <p>3SE52...-0LK5.</p> |
| ¹⁾ Cannot be ordered as complete unit | | | |

- Direction of actuation
- Contact element closed
- Contact element open
- ≤ Maximum actuator travel

4.3 Mechanical position switches

Rod lever made of plastic 3SE5000-0AH00 / 3SE5000-0AJ00 + 3SE5000-0AA80/82

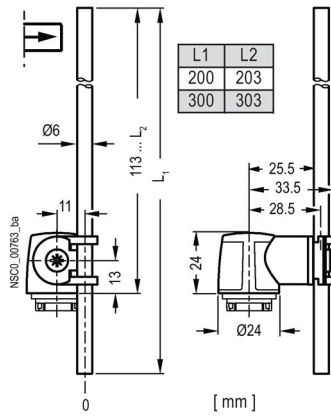



$v_{(plast)} \leq 1.0$ m/s (maximum actuating speed)

$M \geq 0.25$ Nm (minimum torque in actuation direction)

Lever adjustable in increments of 10°, maximum deflection 90°

No positive opening operation

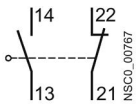
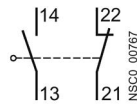
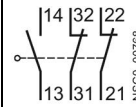
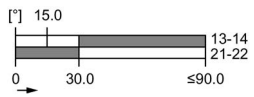
| Slow-action contacts | | | With make-before-break |
|--|--|--|--|
| <p>1 NO + 1 NC</p> <p>Code number 11</p> | <p>1 NO + 2 NC</p> <p>Code number 12</p> | <p>2 NO + 1 NC</p> <p>Code number 21</p> | <p>1 NO + 2 NC</p> <p>Code number 12</p> |
| Deflection in direction of rotation | | | |
| <p>3SE51...-0BH8. ¹⁾ 3SE51...-0BJ8. ¹⁾</p> | <p>3SE51...-0KH8. ¹⁾ 3SE51...-0KJ8. ¹⁾</p> | <p>3SE51...-0PH8. ¹⁾ 3SE51...-0PJ8. ¹⁾</p> | <p>3SE51...-0MH8. ¹⁾ 3SE51...-0MJ8. ¹⁾</p> |
| <p>¹⁾ Cannot be ordered as complete unit</p> | | | |

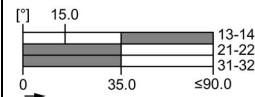
| Snap-action contacts | | |
|--|--|--|
| <p>1 NO + 1 NC</p>  <p>Code number 11</p> | <p>1 NO + 1 NC</p>  <p>Code number 11</p> | <p>1 NO + 2 NC</p>  <p>Code number 12</p> |
| Deflection in direction of rotation | | |
| <p>3SE51..-0CH8. 3SE51..-0CJ8.</p>  | <p>3SE51..-0NH8. ¹⁾ 3SE51..-0NJ8. ¹⁾</p>  <p>Short stroke</p> | <p>3SE51..-0LH8. 3SE51..-0LJ8. ¹⁾</p>  |
| <p>¹⁾ Cannot be ordered as complete unit</p> | | |

4.3 Mechanical position switches

Rod lever made of metal 3SE5000-0AK00 + 3SE5000-0AA80/82

$V_{(met)} \leq 1.5$ m/s (maximum actuating speed)

| Slow-action contacts | | | With make-before-break |
|---|--|--|--|
| <p>1 NO + 1 NC</p> <p>Code number 11</p> | <p>1 NO + 2 NC</p> <p>Code number 12</p> | <p>2 NO + 1 NC</p> <p>Code number 21</p> | <p>1 NO + 2 NC</p> <p>Code number 12</p> |
| Deflection in direction of rotation | | | |
| <p>3SE52...-0BK8. ¹⁾</p> | <p>3SE52...-0KK8. ¹⁾</p> | <p>3SE52...-0PK8. ¹⁾</p> | <p>3SE52...-0MK8. ¹⁾</p> |
| <p>¹⁾ Cannot be ordered as complete unit</p> | | | |

| Snap-action contacts | | | |
|---|--|--|--|
| <p>1 NO + 1 NC</p> <p>Code number 11</p> | <p>1 NO + 1 NC</p> <p>Code number 11</p> | <p>1 NO + 1 NC</p> <p>Code number 11</p> | <p>1 NO + 2 NC</p> <p>Code number 12</p> |
| Deflection in direction of rotation | | | |
| <p>3SE52...-0CK8. ¹⁾ 3SE52...-0HK8.</p> | <p>3SE52...-0GK8. ¹⁾</p> <p>Operating distance 2 x 2 mm</p> | <p>3SE52...-0FK8. ¹⁾</p> <p>Short stroke integrated</p> | <p>3SE52...-0LK8.</p> |
| <p>¹⁾ Cannot be ordered as complete unit</p> | | | |

- Direction of actuation
- Contact element closed
- Contact element open
- ≤ Maximum actuator travel

Fork lever

3SE5000-0AT1. + 3SE5000-0AT0.

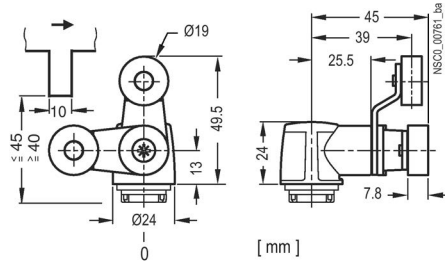

$v \leq 1.5$ m/s (maximum actuating speed)

$M \geq 0.25$ Nm (minimum torque in actuation direction)

Lever adjustable in increments of 10° , maximum deflection 90°

The fork levers can only be used with snap-action contacts.

| Snap-action contacts | |
|---|--|
| <p>1 NO + 1 NC</p> <p>Code number 11</p> | <p>1 NO + 2 NC</p> <p>Code number 12</p> |
| Deflection in direction of rotation | |
| <p>3SE51..-0CT1.</p> | <p>3SE51..-0LT1. ¹⁾</p> |
| <p>¹⁾ Cannot be ordered as complete unit</p> | |

- ⊕ Positive opening operation according to EN 60947-5-1
- Direction of actuation
- Contact element closed
- Contact element open
- ≤ Maximum actuator travel

4.3 Mechanical position switches

4.3.12 Accessories and spare parts

To enable fast replacement of highly-utilized devices with standard enclosure, e.g., in automatic manufacturing lines, a quick-release device and plug connector are offered.

4.3.12.1 Quick-release device for enclosure width 40 mm

3SY3110 - Intermediate plate with screws



3SY3027 - Base plate with locking lever



4.3.12.2 Plug-in connections for connecting thread M20 x 1.5

3SY3131 - Plug connector (6-pin + PE), for M20 x 1.5



For maximum 250 V, 10 A
with connecting cable 0.75 mm², plastic, degree of protection IP65, ambient temperature -40 to +90 °C

3SY3136 - Cable box (6-pin + PE)



With connection compartment (can be pre-assembled), plastic, degree of protection IP65

3SY3127 - Plug connector (4-pin), M12 for M20 x 1.5, fixed



For maximum 250 V, 4 A, $U_{imp} = 2500$ V

With 4 connecting cables 0.25 mm², plastic, degree of protection IP67, ambient temperature -40 to +85 °C

4.3 Mechanical position switches

3SY3128 - Plug connector (5-pin), M12 for M20 × 1.5, fixed



For maximum 125 V, 4 A, $U_{imp} = 1500$ V
with 5 connecting cables 0.25 mm², plastic, degree of protection IP67,
ambient temperature –40 to +85 °C

3SY3134 - Plug connector (8-pin), M12 for M20 × 1.5, fixed, metal version



For maximum 30 V, 2 A, $U_{imp} = 800$ V
with 8 connecting cables 0.25 mm², metal, degree of protection IP67,
ambient temperature –40 to +85 °C

4.3.12.3 Cable gland

The following cable gland can be used:

Cable gland M20 x 1.5





Plastic
3SX9926 (IP67) / 3SX5601-1A (IP69)

NOTICE

Use a seal.

The seal that comes with the cable gland must be used.

4.3.12.4 Adapters

For NPT ½" thread, a cable entry adapter (M20 x 1.5 to NPT ½") made of metal or plastic according to , , and  is available.



Metal
3SX9917



Plastic
3SX9918

4.3.12.5 Protective cover made of plastic



3SE5000-0AC30

Optional accessory for 3SE5 for rounded plunger according to EN 50047

4.4 Mechanical safety switches

4.4.1 Application examples

Different switch types can be used depending on the application.

Position switches with tumbler

Position switches with a tumbler are used when additional locking is required, e.g. in the work zone of a robot system or for monitoring protective doors.

Hinge switches

Hinge switches are used for monitoring hinged doors and flaps, with a fixed positively-locking connection between the switch and door hinge.

4.4.2 Actuator head and actuators

Actuator head

- The actuator head is included in the scope of delivery.
- For actuation from four directions, it can be offset by $4 \times 90^\circ$ (applies only to position switches with separate actuator).
- The switches can also be approached from above.

Actuator

- The actuator is not included in the scope of delivery of the position switches and must be ordered separately.
- You can choose from six variants, depending on the application.
- The actuator is coded. This prevents simple tampering by hand or with tools.

Axial and lateral actuation ($4 \times 90^\circ$)

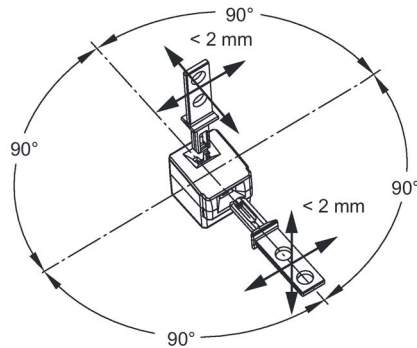

Minimum force requirement in direction of actuation 30 N (when withdrawing)

4.4.3 Operating travel diagrams for mechanical safety switches

The operating travel diagrams for position switches with separate actuator with and without tumbler are identical.

| Slow-action contacts | |
|--|--|
| <p>1 NO + 1 NC</p> <p>Code number 11</p> | <p>1 NO + 1 NC</p> <p>Code number 12</p> |
| With lateral/axial actuation | |
| <p>3SE5...-RV..</p> | <p>3SE5...-QV..</p> |

- ⊕ Positive opening operation according to EN 60947-5-1
 - Direction of actuation
 - Contact element closed
 - Contact element open
 - ≥ Minimum actuator travel
- Actuator in actuator head = Normally closed contact is closed

4.4 Mechanical safety switches

4.4.4 Combinations

Actuator

The actuators for position switches with separate actuator with and without tumbler are identical. The actuator 3SE5000-0AW11 must not be used on a position switch with a separate actuator with tumbler.

| Minimum actuation radius without tumbler | Minimum actuation radius with tumbler |
|--|---------------------------------------|
| | |
| Article number of actuator | R _{min} [mm] |
| 3SE5000-0AV01 | 400 |
| 3SE5000-0AV02 | 400 |
| 3SE5000-0AV03 | 400 |
| 3SE5000-0AW11 | 400 |
| 3SE5000-0AW42 | 400 |
| 3SE5000-0AW43 | 400 |
| 3SE5000-0AW51 | 400 |
| 3SE5000-0AW52 | 400 |
| 3SE5000-0AW53 | 400 |
| 3SE5000-0AV04 | 150 |
| 3SE5000-0AV05 | 150 |
| 3SE5000-0AV06 | 150 |
| 3SE5000-0AV07 | 150 |
| 3SE5000-0AV07-1AK2 | 150 |

4.4.5 Actuator accessories

The accessories for safety switches with separate actuator with and without tumbler are identical.

NOTICE

Risk of property damage.

The position switch can be damaged.

To maintain the level of safety, the actuators are permitted to be used only in combination with the associated safety switch. The actuators must be ordered separately.

Assemble the position switch and actuator in such a way that the actuator can move into the actuator head within the insertion tolerances < 2 mm (see Actuator head and actuators (Page 134)).

Standard actuator

3SE5000-0AV01

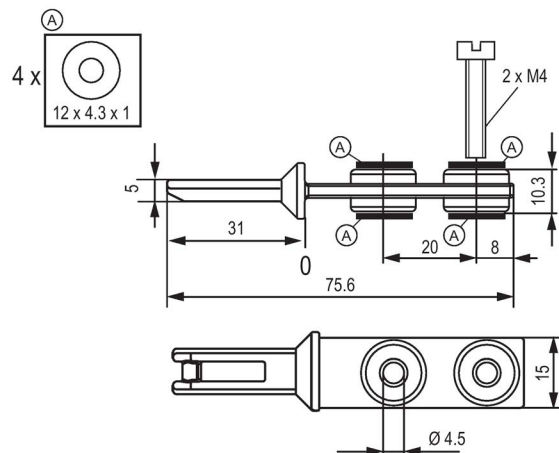

4.4 Mechanical safety switches

3SE5000-0AW51

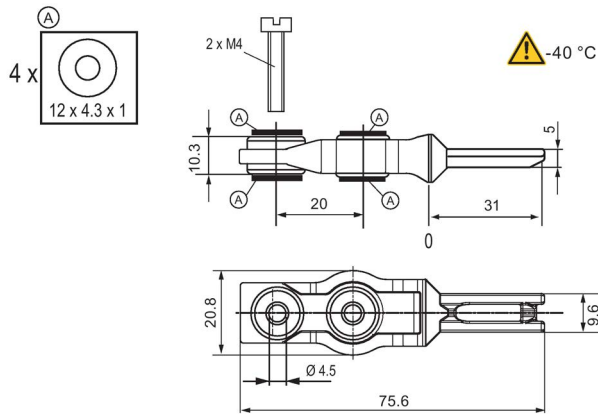

NOTICE

Risk of damage to the actuator and switch.

When mounting the actuator, use the four washers included on the upper and lower sides of the rubber sleeves.

Never remove the barrels that are located inside the rubber sleeves.

Actuators with vertical and horizontal mounting

Actuator with vertical mounting 3SE5000-0AV02

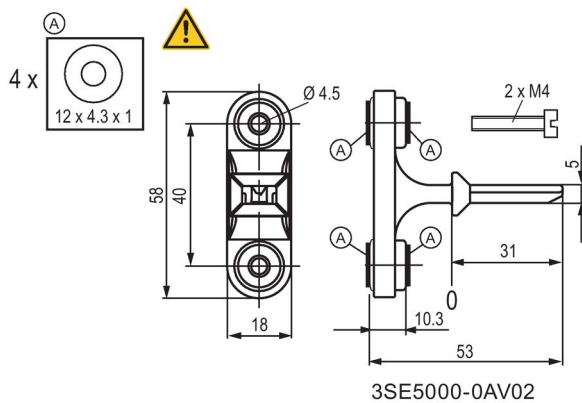

3SE5000-0AW52

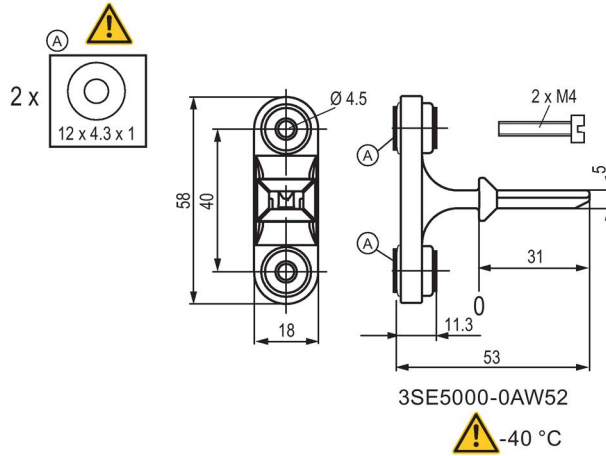

Actuator with vertical mounting with flanged sockets 3SE5000-0AW42

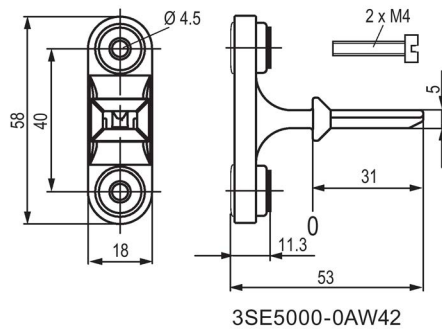

Actuator with horizontal mounting 3SE5000-0AV03

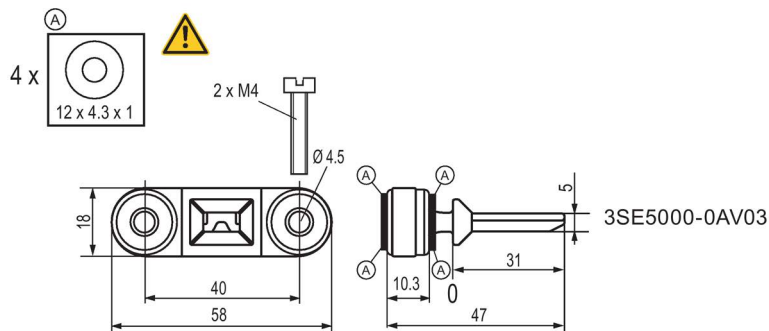

4.4 Mechanical safety switches

3SE5000-0AW53

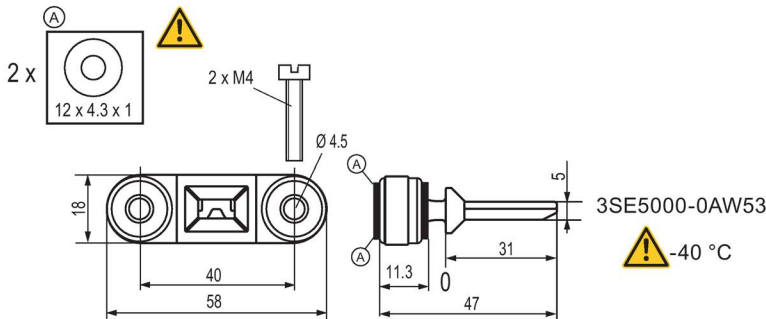

NOTICE

Risk of damage to the actuator and switch.

When mounting the actuator, use the two washers included on the upper side of the rubber sleeves.

Never remove the barrels that are located inside the rubber sleeves.

Actuator with horizontal mounting with flanged sockets 3SE5000-0AW43

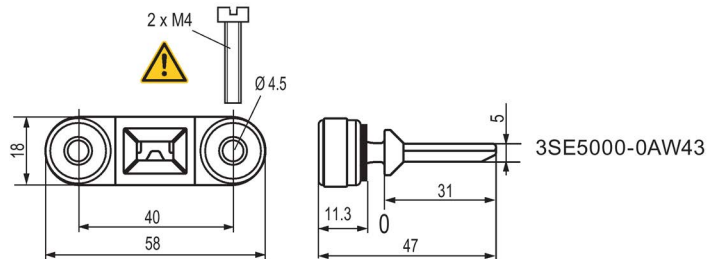

NOTICE

Risk of damage to the actuator and switch.

No washers need to be used for the actuators with flanged sockets.

Never remove the integrated flanged sockets.

Plastic standard actuators 3SE5000-0AW11

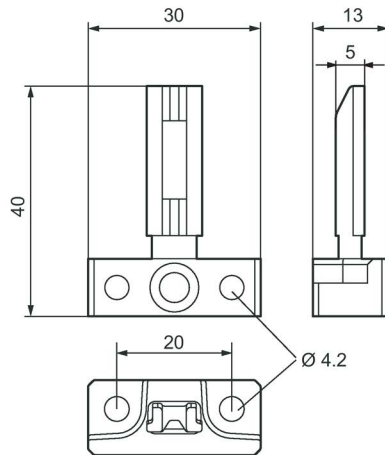

⚠ WARNING

Improper use may cause a risk of death.

Do not use the 3SE5000-0AW11 actuator for the following position switches with tumbler:
3SE5322-..... / 3SE5312-.... and 3SF1324-.... / 3SF1314-....

4.4 Mechanical safety switches

Radius actuator

The position switches with radius actuator are especially well-suited for rotatable protective devices. The movable operating key enables the switch to approach even in the case of small actuating radii. Damage to the switch and actuator as a result of imprecise approaching is avoided.

- Approach from left 3SE5000-0AV04

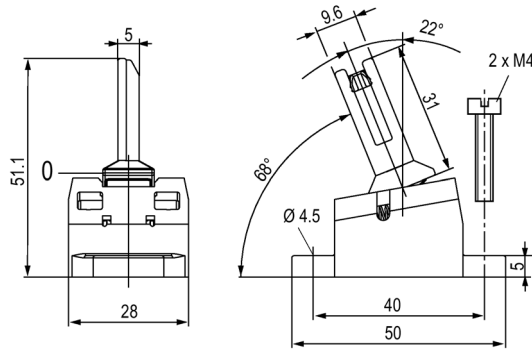

- Approach from right 3SE5000-0AV06

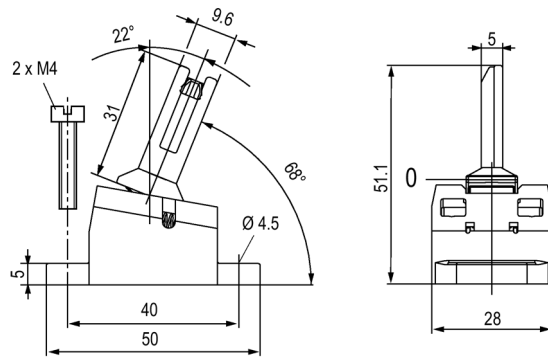

Note

Observe settings.

Observe the radii (R) and suitable distances (X) from the following table.

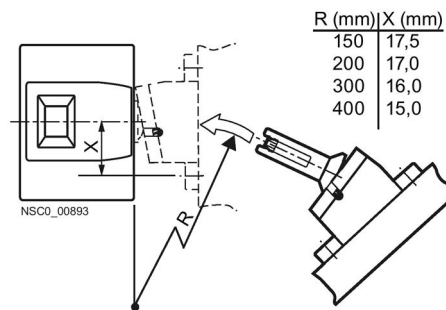

Radius actuator

Setting the radius actuator

1. Release the actuator's screws.
2. Insert the actuator at the required angle.
3. Fix the actuator in place by tightening the screw.

Note

Pay attention to the torque.

When setting the actuation angle, you must tighten the fixing screw to at least 1.5 Nm.

Universal radius actuator

3SE5000-0AV05

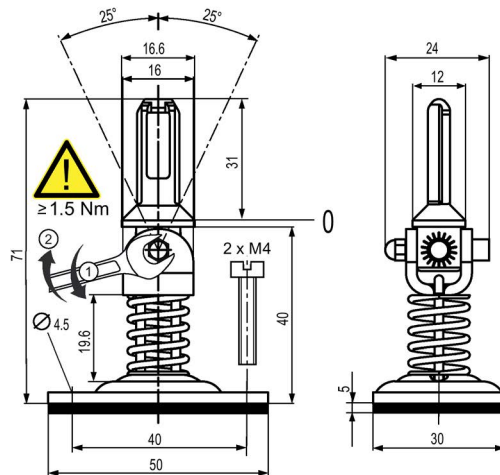

4.4 Mechanical safety switches

3SE5000-0AV05-1AA6

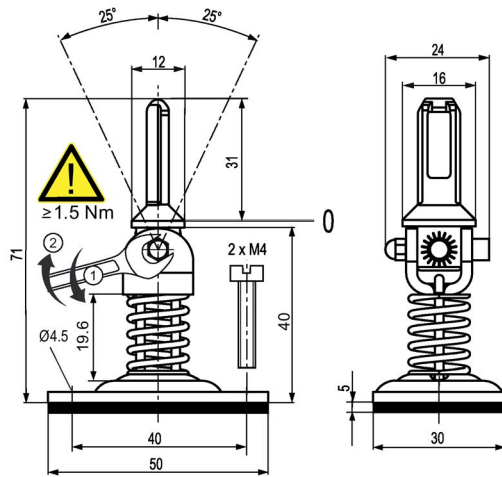

Heavy Duty 3SE5000-0AV07

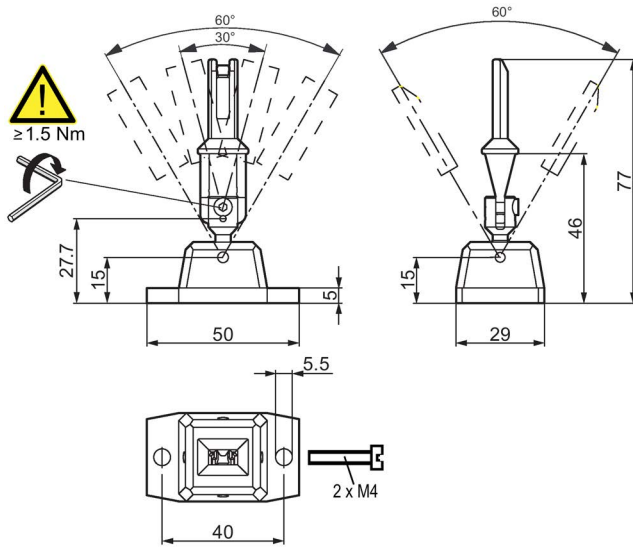

Heavy Duty 3SE5000-0AV07-1AK2

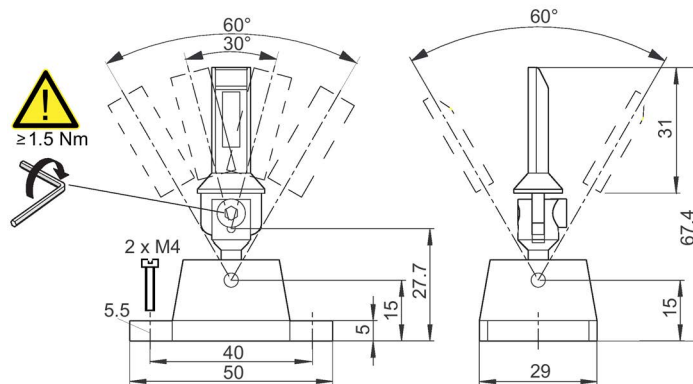

Locking device 3SE5000-0AV08-1AA3

To ensure safety of several persons in the work zone (prevention of unauthorized commissioning), a stainless steel lock insert that accommodates up to eight padlocks is offered.

The lock is not included in the scope of delivery.

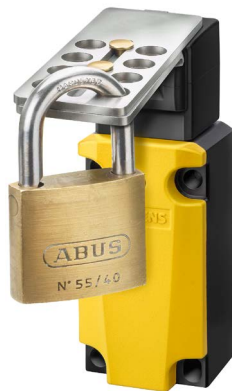

Lock insert with padlock



Lock insert, open

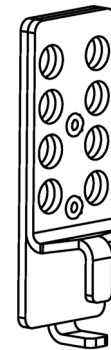

Lock insert, closed

4.4 Mechanical safety switches

Dust cap 3SE5000-0AV08-1AA2

For use in dusty environments, a protective cap is offered that protects the actuator entries of the actuator head from dirt.

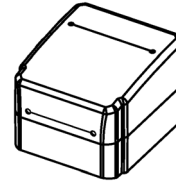

Note

Proper attachment of dust cap.

Make sure when attaching the dust cap that its slots are located at the top and front of the actuator head.



Note

You cannot use the dust cap for plastic enclosures.

4.5 Mechanical safety switches with separate actuation

The mechanical safety switches with separate actuator without tumbler are used for applications where the position of doors, covers, or protective grilles must be monitored for safety reasons. The 3SE5 position switches with separate actuator have the same enclosure as the 3SE5 mechanical position switches (modular system).



You will find additional information on applications in Chapter Application example of safety switch without tumbler (Page 253)

4.5.1 3SE22 safety switches with separate actuation



Application areas of 3SE2257 and 3SE2243 safety switches

3SE2257 and 3SE2243 safety switches are used on protective grilles, covers and doors that have to be closed to warrant the required operational safety.

4.5 Mechanical safety switches with separate actuation

4.5.2 Mounting instructions for safety switches with separate actuation

Please observe the following installation notes when installing 3SE2243 / 3SE2257 position switches:

Mounting with fixing bolts

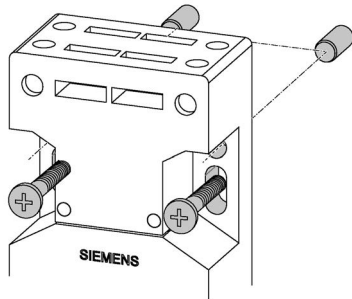

To avoid shifting on approach from above, optional fixing bolts can be used for precise adjustment.

When the device is replaced, an exact position is kept to and readjustment is not necessary.

The switch must be additionally fastened with two screws.

Possible approach directions of actuators

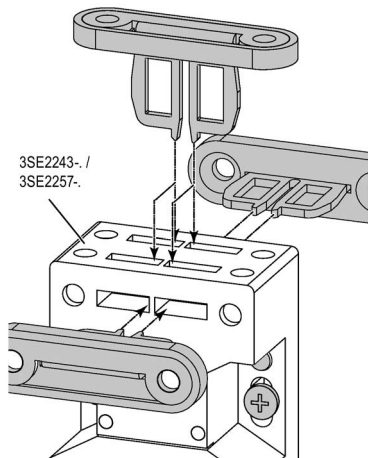

Radius actuator

Lateral (a) and vertical (b) presetting are possible for the radius actuator.

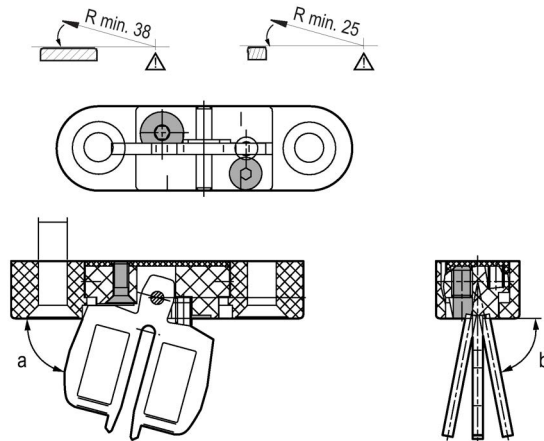

4.5.3 Technical data for mechanical safety switches with separate actuation

4.5.3.1 Technical data in Siemens Industry Online Support

Technical data sheet

You can also find the technical data of the product at Siemens Industry Online Support (<https://support.industry.siemens.com/cs/ww/en/ps/>).

1. Enter the full article number of the desired device in the "Product" field, and confirm with the Enter key.
2. Click the "Technical data link."

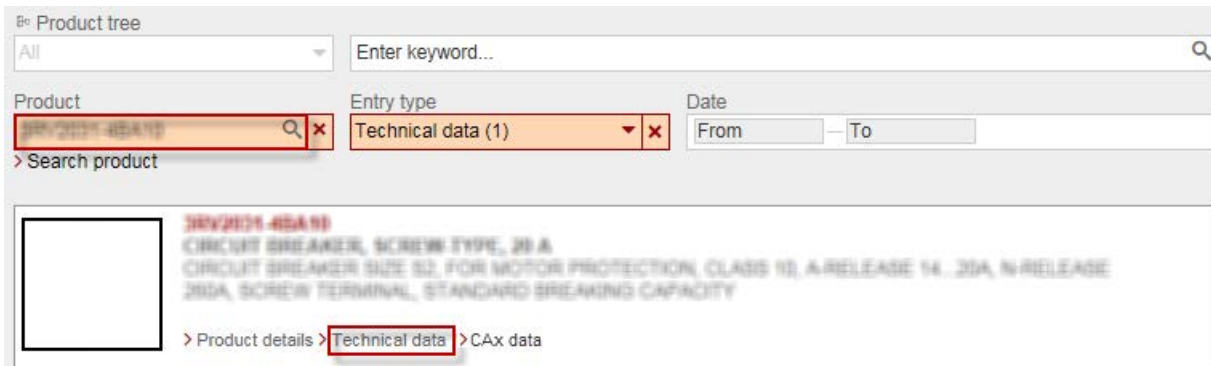

4.5 Mechanical safety switches with separate actuation

4.5.4 Dimension drawings and operating travel diagrams

4.5.4.1 3SE5 mechanical safety switches with separate actuation

Complete units

| | |
|---|---|
| Enclosure according to EN 50047 | |
| Enclosure width 31 mm 3SE523.-.QV40, 3SE523.-.RV40 (plastic) 3SE521.-.QV40, 3SE521.-.RV40 (metal) | Enclosure width 50 mm 3SE524.-.QV40, 3SE524.-.RV40 (plastic) |
| | |
| Enclosure acc. to EN 50041 | |
| Enclosure width 40 mm 3SE511.-.QV10, 3SE511.-.RV10 (metal) 3SE5132-0QV20 (plastic) | Enclosure width 56 mm 3SE512.-.QV10, 3SE512.-.RV10 (metal) |
| | |

4.5.4.2 3SE22 safety switches with separate actuation

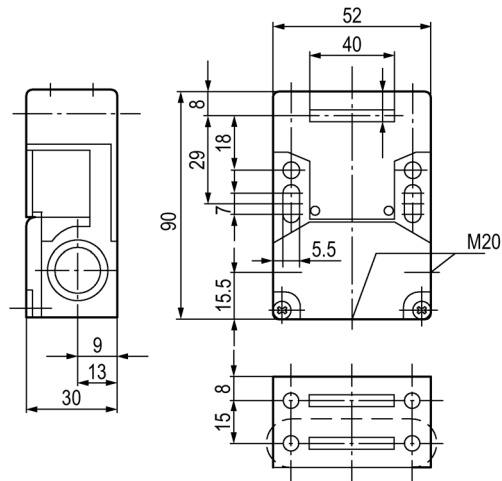

Figure 4-4 3SE2243 safety position switch with separate actuator with lateral and front actuation

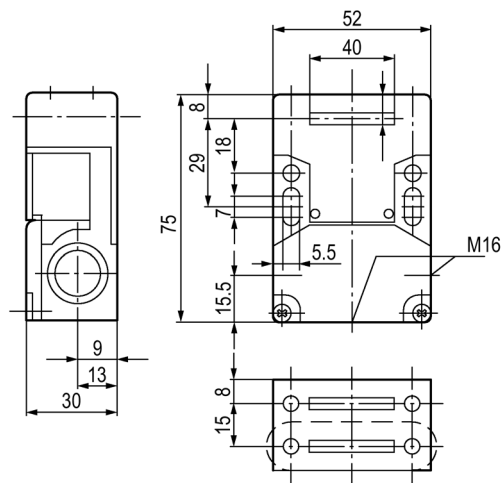

Figure 4-5 3SE2257 safety position switch with separate actuator with lateral and front actuation

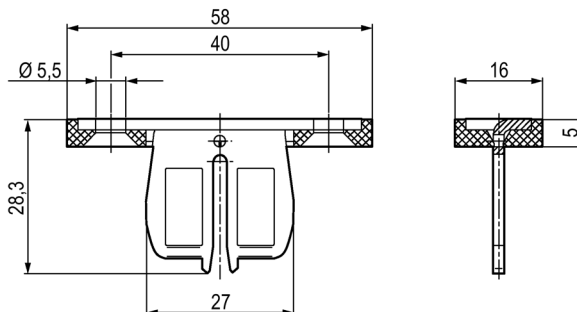

Figure 4-6 3SX3218 standard actuator

4.5 Mechanical safety switches with separate actuation

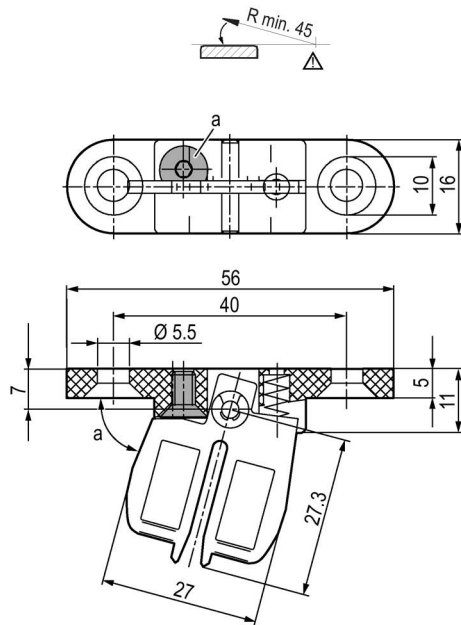

Figure 4-7 3SX3256 radius actuator, radius adjustable

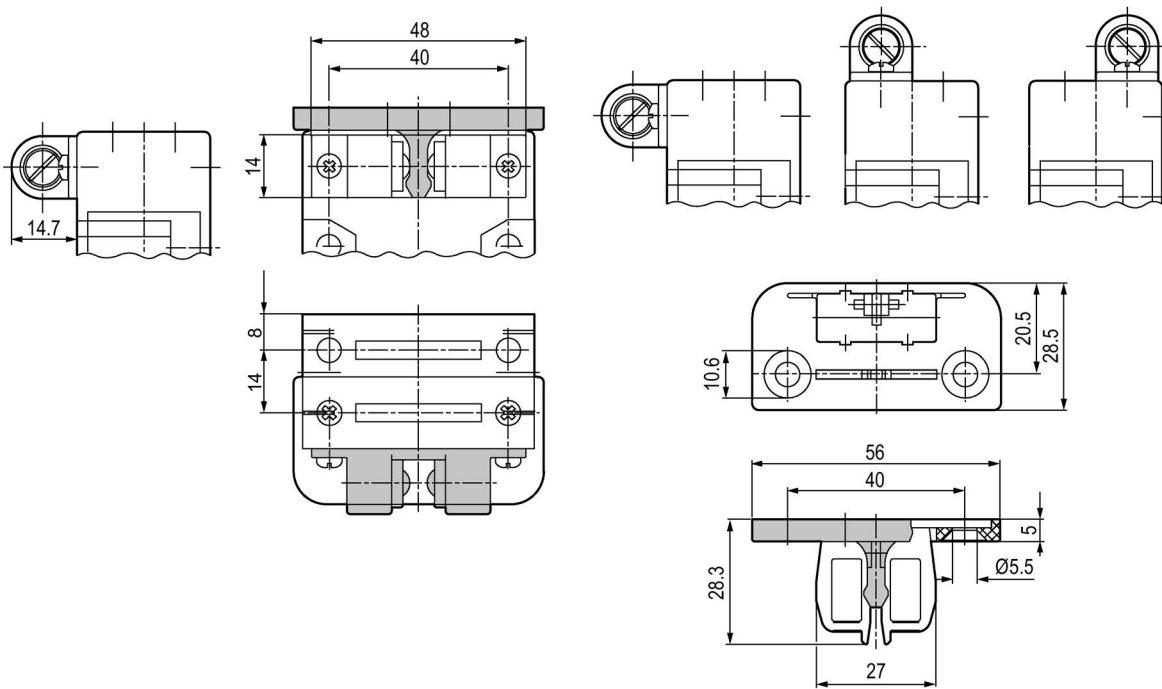

Figure 4-8 3SX3217 separate actuator with ball locating

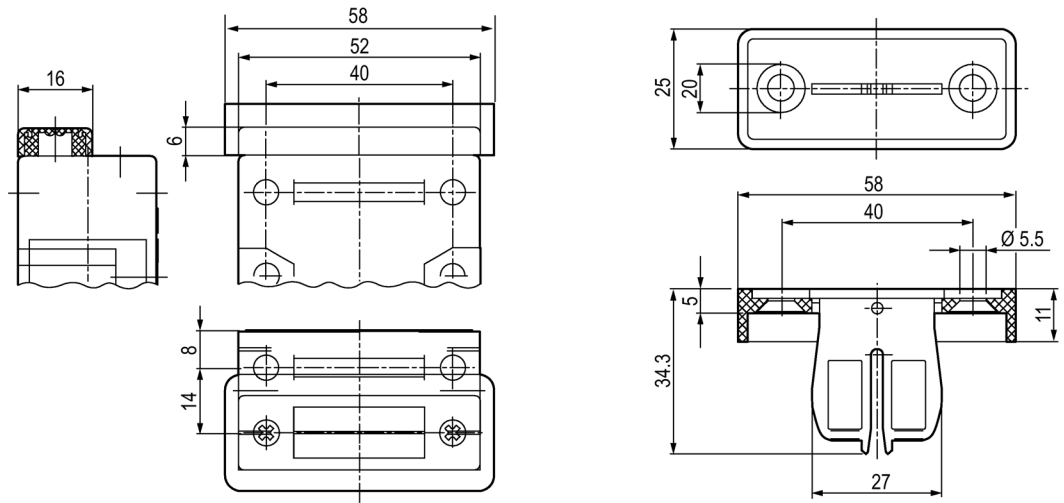

Figure 4-9 3SX3234 separate actuator with dust protection and slit covers

4.5 Mechanical safety switches with separate actuation

4.5.4.3 Operating travel diagrams of position switches with separate actuation

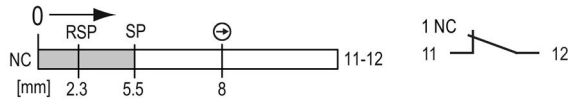

Figure 4-10 3SE2257-6XX

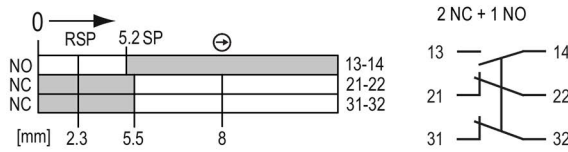

Figure 4-11 3SE2243-0XX

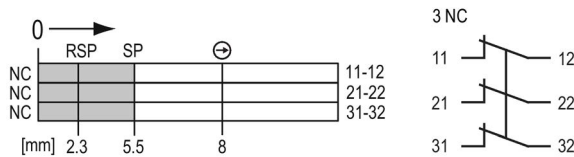





Figure 4-12 3SE2243-6XX

| | |
|---|----------------------------|
| NC | NC contact |
| NO | NO contact |
| ⊕ | Positive opening operation |
| BW | Actuator travel |
| SP | Switching point |
| RSP | Switching-back point |
|  | Contact element closed |
|  | Contact element open |

4.5.5 Accessories for 3SE22 safety switches

3SE22 safety switches can be supplied without actuators. The following actuators are available as accessories:

Actuators for 3SE22 safety switches

| 3SX3218 | 3SX3228 | 3SX3256 | 3SX3217 | 3SX3234 |
|---|---|---|--|---|
|  |  |  |  |  |
| Standard actuator | Universal radius actuator | Radius actuator | Separate actuator with ball locating | Actuator |
| $r_{\min} = 150 \text{ mm}$, length 28 mm | $r_{\min} = 45 \text{ mm}$, length 34 mm | Radius adjustable, length 34 mm | Force adjustable up to max. 100 N by 2 screws, length 28 mm | with dust protection and slit cover, length 34 mm |

4.6 Mechanical safety switches with tumbler

Safety switches with separate actuator and additional electromagnetic tumbler are used when the shutdown of machines calls for closed protective doors. For example, this is the case when protecting the work zone of a robot system.

An integrated auxiliary magnet keeps the protective door locked until a specific signal is received. The actuator cannot be withdrawn with a pulling force of 2600 N for metal variants and 1300 N for plastic variants. A safety locking mechanism also ensures that the normally closed contacts of the magnet are never closed while the door is open. The switch can be released manually using an auxiliary release mechanism if, for example, access is required following a power failure or during installation.

Properties

- Integrated tumbler with 24 V, 115 V, or 230 V coil voltage
- Default assembly with 6 switching contacts (actuator 1 NO + 2 NC; magnet 1 NO + 2 NC)
- Separate evaluation of the magnet position and the protective door position
- Optical signaling devices enable reliable status monitoring

Safety switches with tumbler are special safety-related devices that prevent accidental or intentional opening of protective doors, protective grilles, or other covers as long as dangerous conditions exist, e.g., follow-on motions of shut-down machines.

4.6 Mechanical safety switches with tumbler



Safety switches with tumbler consist of a switch part with electromechanical tumbler and a mechanical actuator, which must be ordered separately. These rugged protective devices provide the greatest possible safety for humans and machines. The safety switches with tumbler are offered with a plastic or metal enclosure.

Dimensions (W × H × D)

- 3SE53: 54 mm × 185 mm × 43.5 mm

Safety function in accordance with DIN EN ISO 14119

In accordance with DIN EN ISO 14119, the safety switches with tumbler are type 2 devices with a low coding level. The position switch can only be switched with the associated triple-coded actuator.

Safety function A: interlock

Position monitoring for a guard on a machine. The mechanical actuator is mounted on the guard. When the guard is opened, the mechanical actuator is pulled out of the safety switch and the safety contacts of the actuator contact block (11-12 and 21-22) are positively opened. These safety contacts are monitored in the subsequent controller or evaluation unit. Simple overruling by hand or auxiliary devices is impossible.

Safety function B: tumbler

The guard is held shut during a hazardous machine function. During this time, the actuator cannot be removed from the safety switch until the controller has issued the enabling signal (to operate the magnet). The position of the tumbler is monitored via the contacts of the magnet contact block (41-42, 51-52, 63-64). The position of the tumbler's contacts should be fed back to the controller, where they should be compared with the magnet's control signal for plausibility.

Protection from manipulation

Mechanical safety switches with separate actuator offer "Protection against easy bypassing". Actuation with a simple tool (e.g., screwdriver) and other aids (e.g., wires, pencils, adhesive tape) is not possible.

Exception

Removal of components of the position switch or separate actuator, as well as jumpering of the switching contacts, is regarded as a deliberate action and not as "easy bypassing".

Coding

The separate actuator is triple-coded and acts like a key. Once an actuator and switch are functionally joined together (protective device closed), a machine or plant can begin operation. When the protective device is opened, a positively-locking, positive-opening operation of the normally closed contacts becomes operative. The switching contact remains positively opened until the actuator is inserted again. Additional expenses for, e.g., an approach rod or switching cam, as is necessary for conventional position switches, as well as shielding measures for tamper protection, do not apply in the case of the switches. Installing the switch on the machine at a location that is as concealed and inaccessible as possible provides additional protection against manipulation.

| |
|--|
|  WARNING |
| Improper use may cause a risk of death. |
| You must not use the 3SE5000-0AW11 actuator for position switches with tumbler. |

The actuator head is included in the scope of delivery. It can be offset by $4 \times 90^\circ$ to allow actuation from four directions. The 3SE5 3 switches can also be approached from above.

The actuator is not included in the scope of delivery of the position switches and must be ordered separately. There are six variants to choose from, depending on the application.

Actuation data:

- Maximum actuating speed $v_{\max} = 1.5 \text{ m/s}$
- Minimum actuating speed $v_{\min} = 0.4 \text{ mm/s}$
- Minimum force in direction of actuation $F_{\min} = 30 \text{ N}$

Operation

Safety switches with tumbler can only be switched with the associated triple-coded actuator. This prevents simple tampering by hand or with tools.

The normally closed contact is positively opened and the normally open contact is closed by pulling the actuator.

Insertion guides

For large doors, insertion funnels/guides for positioning of switches must be used.

4.6 Mechanical safety switches with tumbler

Contact block

Two contacts with two positive-opening normally closed contacts and one normally open contact are used (terminal markings according to EN 50013).

Note

The safety switches with tumbler have one contact block each for the following:

- Monitoring the actuator or position of the protective door
- Monitoring the position of the magnet

The mechanical design of the switches corresponds to the requirements of the fail-safe principle according to DIN EN ISO 14119.

4.6.1 Interlock types

There are two versions for interlocking the actuator:

- **Spring-locked** (closed-circuit principle): Actuator inserted and mechanically interlocked. Actuator is released by applying voltage to the magnet or, in the case of voltage drop, by means of a manual or key-operated auxiliary release mechanism (version-dependent).
Release variants:
 - Auxiliary release
 - Key-operated release
 - Emergency release
 - Escape release
- **Solenoid-locked** (open-circuit principle): Actuator released. Actuator is interlocked by applying voltage to the magnet. Actuator is released by switching off the voltage applied to the magnet.















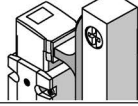

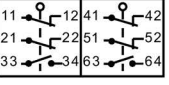



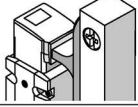

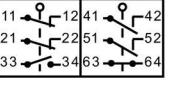
Note

Risk analysis

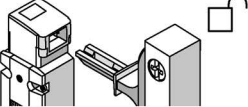
Tumblers based on the open-circuit principle may only be used if the application's risk analysis shows that use of closed-circuit current variants is not possible. An identical safety level must be established by suitable measures.

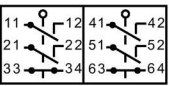
Meaning of switch positions and LED indications

The switches have a display with four LEDs:

| |  |  | 3SE53.2-.S...  | 3SE53.2-.SB..  | | |
|---|---|---|---|--|---|---|
| ① |  |  |  |  |  | LED  |
| ② |  |  |  |  |  | LED  |
| ③ |  |  |  |  |  | LED  |

| | | Switch position | Switch with spring lock (closed-circuit principle) | Switch with solenoid lock (open-circuit principle) | LED display |
|---|--|---|--|--|---|
| ① | The actuator is inserted. The protective device is interlocked. | 11/12, 21/22, 41/42, 51/52 closed; 33/34, 63/64 open | Magnet not energized. | Magnet energized. | LED 1 = off LED 2 = off LED 3 = off LED 4 = lit green |
| ② | The actuator is inserted. The protective device is not interlocked. | 11/12, 21/22, 63/64 closed; 41/42, 51/52, 33/34 open | Magnet energized. | Magnet not energized. | LED 1 = off LED 2 = off LED 3 = lit yellow LED 4 = lit green |
| ③ | The actuator is withdrawn. The protective device is not interlocked. | 33/34, 63/64 closed; 11/12, 21/22, 41/42, 51/52 open | Magnet energized. | Magnet not energized. | LED 1 = off LED 2 = off LED 3 = lit yellow LED 4 = off |

4.6 Mechanical safety switches with tumbler

| |
|--|
| ! WARNING |
| Releasing the solenoid-locked switch |
| The tumbler of the solenoid-locked switches is released by deactivating the current. Do not use these switches if there is a hazard due to releasing in the event of voltage failure. Carry out a risk analysis with regard to the safety level. |

For emergency situations or for setup mode, the spring-locked switch is equipped with an auxiliary release. The following variants are available as options (3SE5 only):

- An escape release, or
- An emergency release

Auxiliary release



3SE53.2-0SD2.

Note

The auxiliary release may only be used when the tumbler fails.

| |
|--|
| ! DANGER |
| Risk of death. Possibility of unauthorized use. |
| The switch can be manipulated. |
| Seal the access point of the auxiliary release following installation. |

Auxiliary release with lock

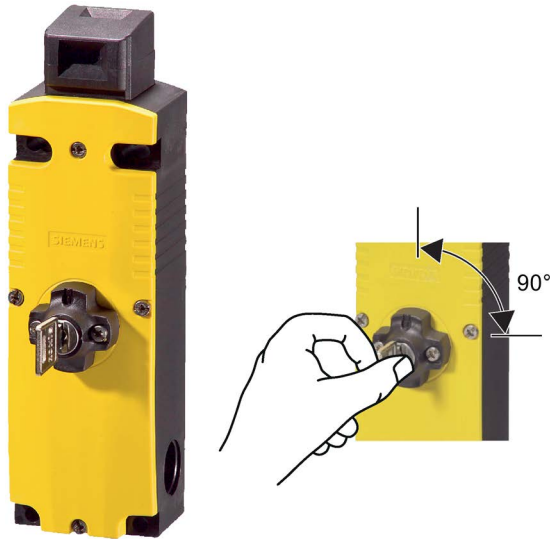

3SE53.2-0SE2.

Rotation of the key of the key-operated auxiliary release by an authorized person releases the tumbler. The actuator is released for withdrawal.

Eliminate the dangerous situation. An authorized person resets the device to operating mode by turning the key (clockwise). The key can be withdrawn.

Front escape release

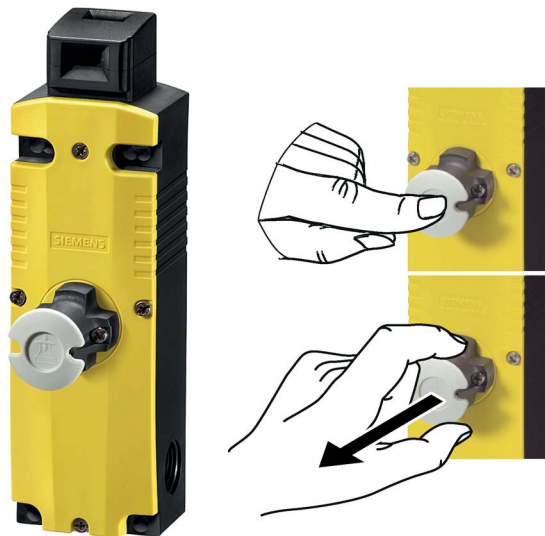

3SE53.2-0SF2.

Rear escape release and front auxiliary release

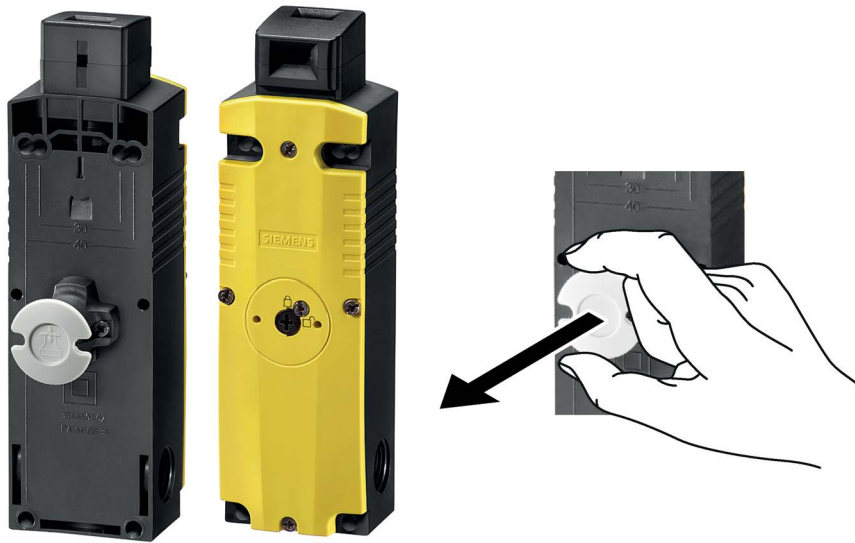

3SE53.2-0SG2.

The escape release is intended for use cases in which the possibility for escape or rescue of persons is required. Its purpose is to release the safety interlock without an auxiliary tool in dangerous situations.

A deliberate action on the device is required to cancel the block and restore the ready-to-operate condition.

Rear emergency release and front auxiliary release

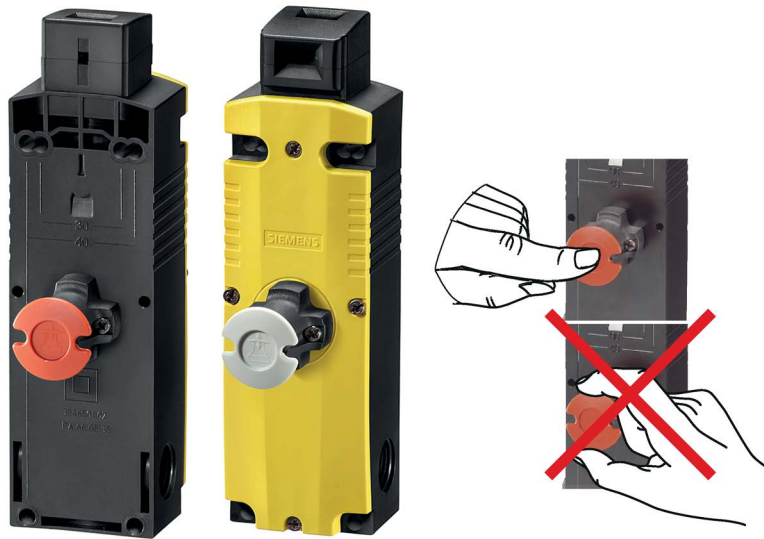

3SE53.2-0SJ1.

Manual activation of the emergency pushbutton by any person in the danger zone releases the tumbler. The actuator is released for withdrawal.

Safety switches equipped with the escape release option must be installed within the danger zone. The escape release may only be operated to allow a person to exit the danger zone in the event of a system failure.

Emergency release

The emergency release enables someone in an emergency situation to manually release a position switch with tumbler and thus to open a protective device without tools from the access side (of the hazardous area). The transport lock (T, Fig. 1) must be removed before commissioning! Pressing the emergency release (red pushbutton D, Fig. 1) causes mechanical release of the tumbler and also actuation of the contacts for monitoring the interlocking magnet.

4.6 Mechanical safety switches with tumbler

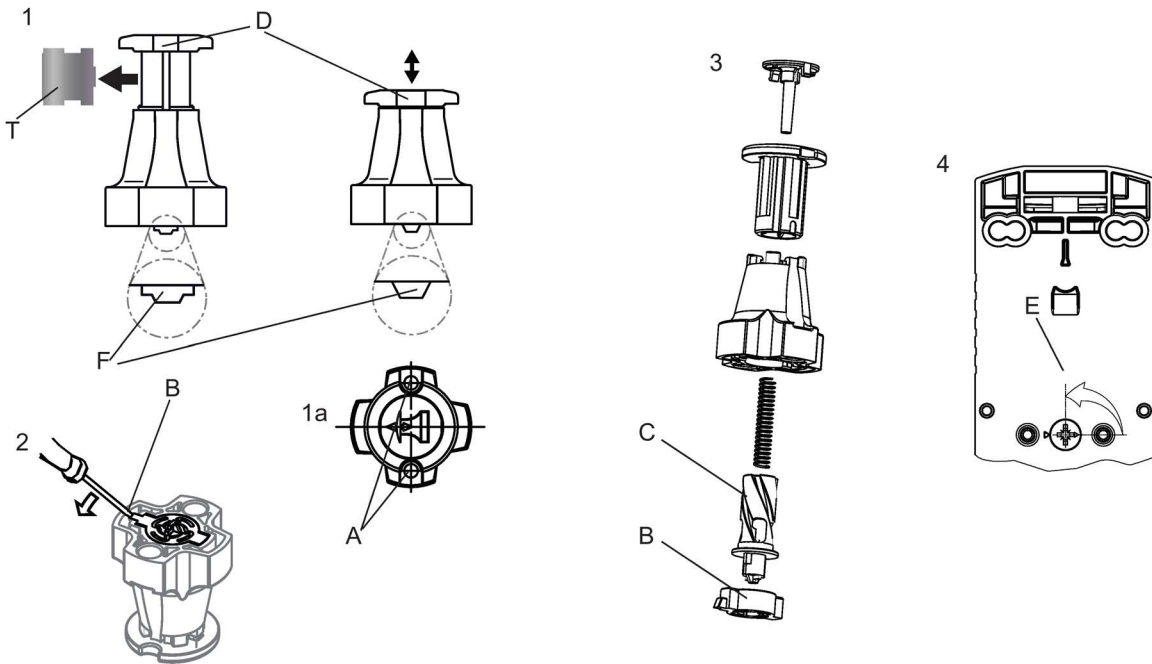

Note

Resetting the emergency release

Only authorized persons may reset the emergency release.

It is imperative to adhere to the following work steps and resetting must be done according to the mounting position (Fig. 3):

1. Release the screws (A) (Fig. 1a).
2. NOTICE: Turn the release (E) on the position switch (Fig. 4) by 90° to the left (reset).
3. Lever out the locking ring (B) (Fig. 2).
4. Press the plunger (C) into the emergency release (Fig. 3) and turn it to the right (90°). The plunger is released (do not pull it out fully).
5. Pull out the pushbutton (D) completely up to the endstop (Fig. 1).
6. Push the plunger (C) back in again and press in the locking ring (B) down to the endstop (Fig. 2).
7. NOTICE: Note the key position (F).
8. Screw on the emergency release again.

4.6.2 Typical circuit diagram with evaluation unit in accordance with SIL2

Note

The control signal of the tumbler must be checked for consistency (cross-check of the tumbler contact block and the control signal for solenoid operation).

| Function | Safety category |
|-----------|-----------------|
| Interlock | max. PLe/Cat. 3 |
| Tumbler | max. PLd/Cat. 2 |

4.6 Mechanical safety switches with tumbler

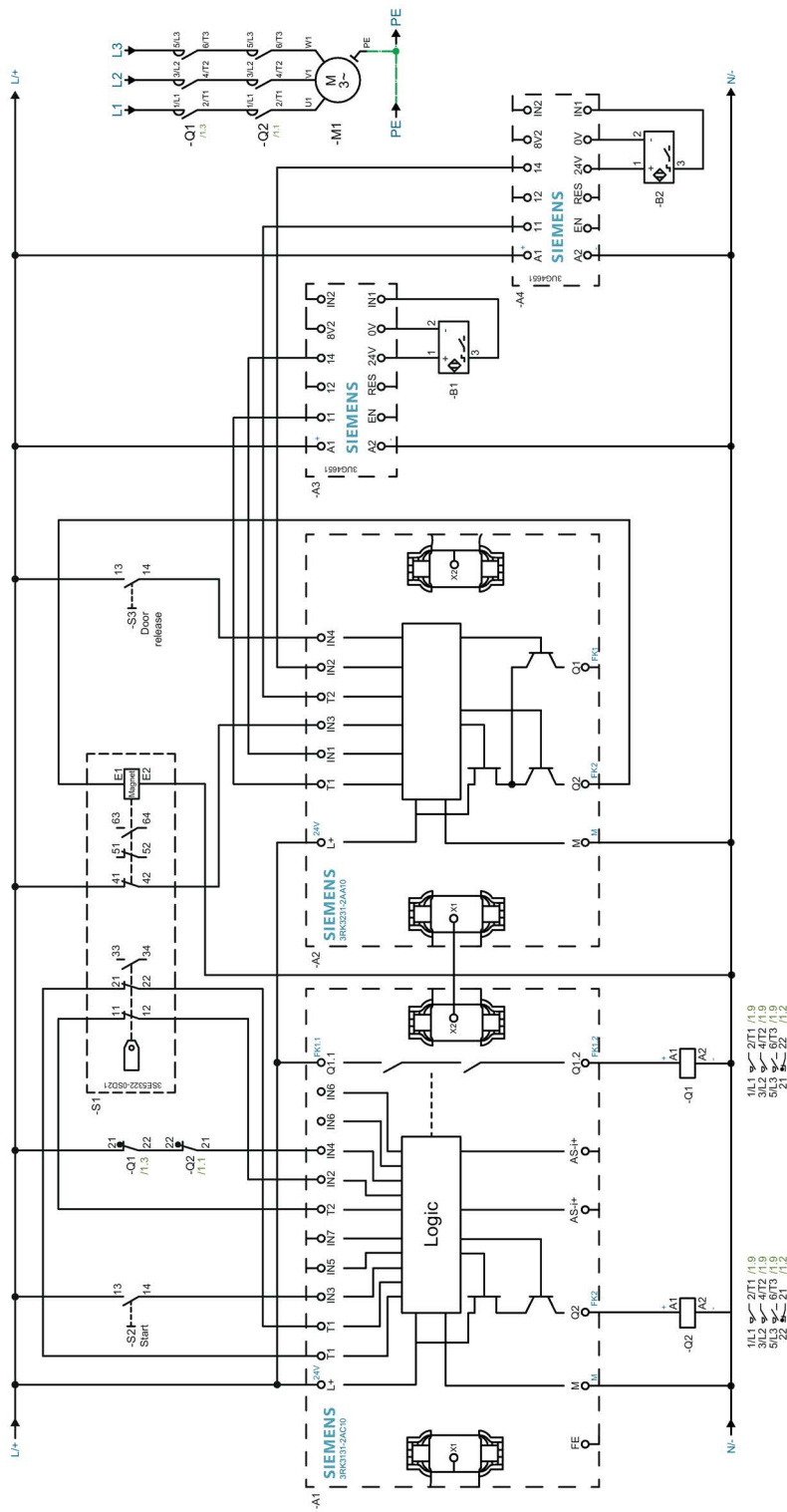

4.6.3 Installing and securing the actuator head

Installing/removing the actuator head

Note

Please observe misalignment!

Any misalignment when inserting the actuator must be less than 2 mm. The actuator head can be rotated in 90-degree steps.

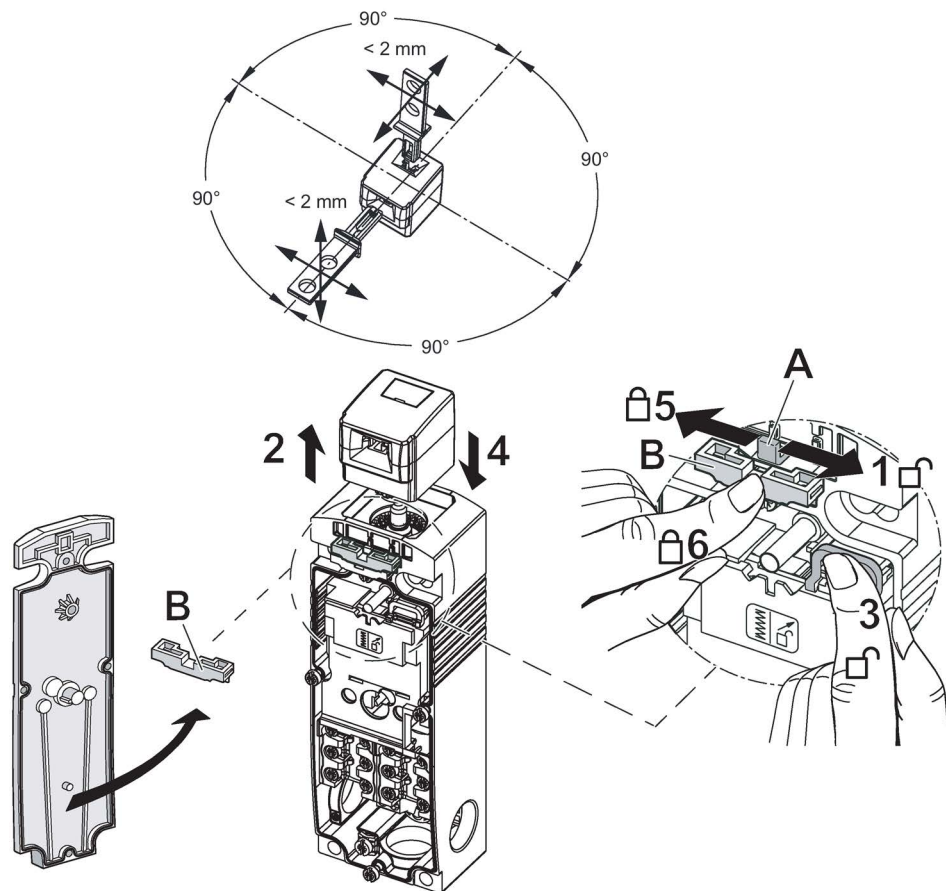

1. Release the actuator head by sliding the locking plate (A) to the right.
2. Pull the actuator head out upwards.
3. Press the auxiliary release lever.
4. Reinsert the actuator head.
5. Lock the actuator head back into place by sliding the locking plate to the left into the middle position. The actuator head is locked in place.
6. To secure the locking plate, push in the filler (B) (mounted on the inside of the cover) while the actuator head is locked in place. This secures the closed locking plate (A) against unauthorized opening. The actuator head can no longer be rotated.

4.6 Mechanical safety switches with tumbler

Note

Do not use the position switch as an endstop, as this may influence the way it functions.

4.6.4 Notes on installation

Position switch with tumbler

 **WARNING**

Repair and maintenance

The components of existing tumbler systems, such as switches, actuator heads or actuators, may not be replaced individually. To maintain the safety level, the whole tumbler system, consisting of the switch, actuator head and actuator, must always be replaced in its entirety.

 **WARNING**

Protection against damage

Protect the routed cables against unintentional damage, in order to avoid discontinuities or cross-circuits in the signal path or in the voltage supply of the solenoid.

Route the connecting cable in a cable duct, for example.

Do not pull on the wiring or connecting cable in order to avoid damage.

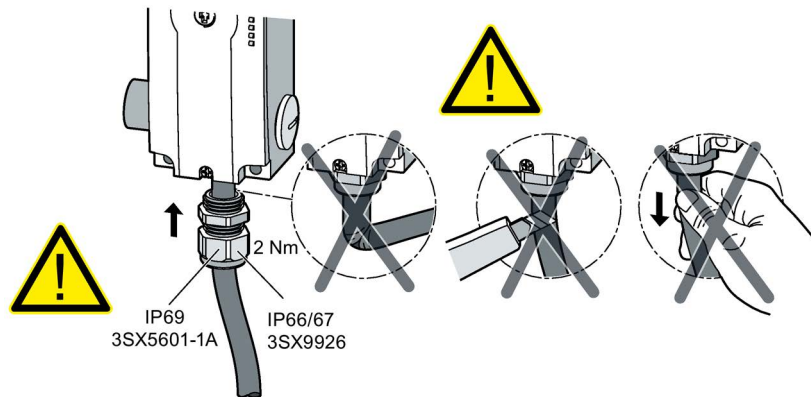
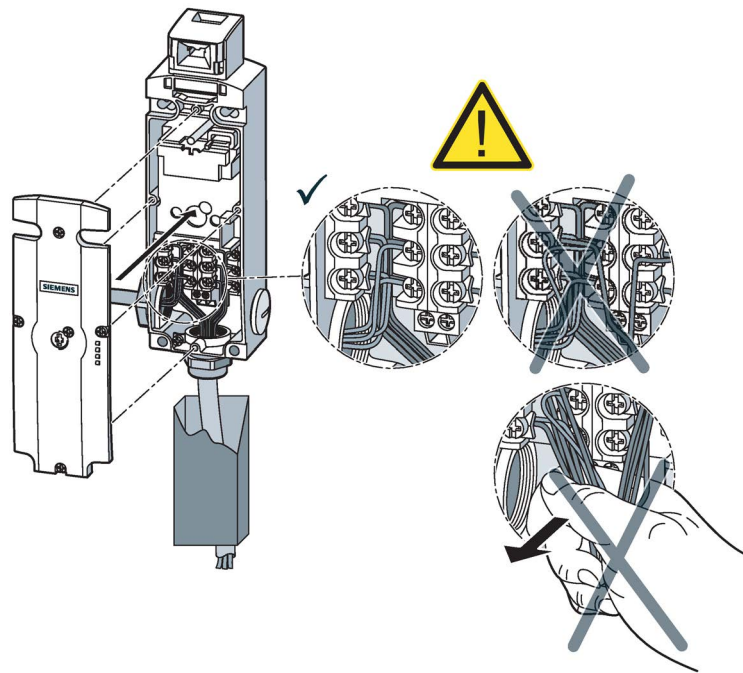

Note

Regularly check correct functioning.

Check correct functioning of the switch once a year.

4.6 Mechanical safety switches with tumbler

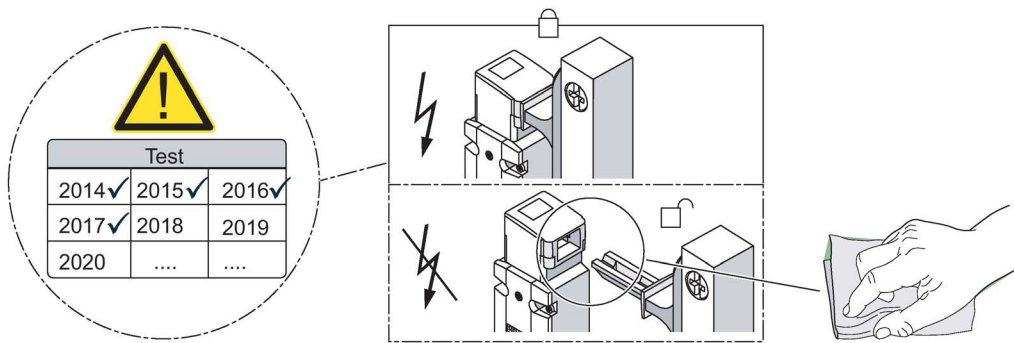

Note

Observe the following note from the DIN EN ISO 14119 standard:

Environmental conditions considerations (e.g. hygiene, temperature, dust, humidity, etc.)
 Dirt must be regularly cleaned from the switch. You can obtain further information from
 Technical Assistance (see Latest information (Page 13)).

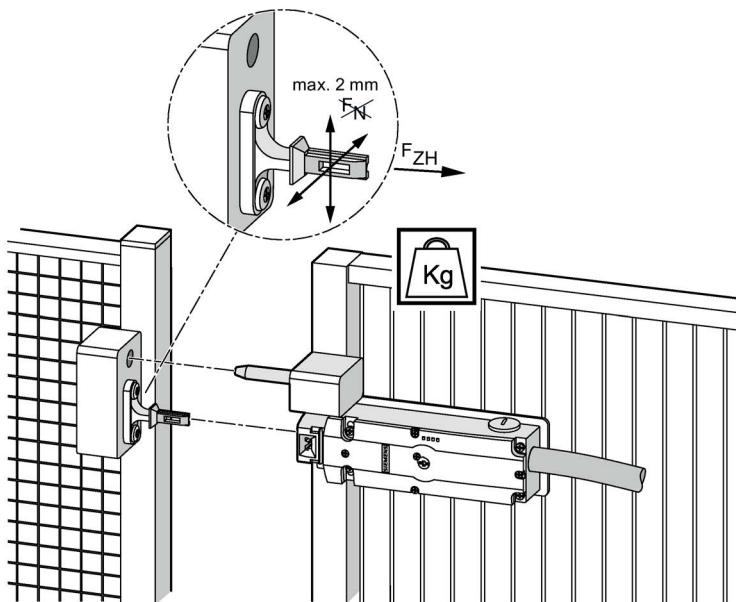

! WARNING

Use actuators only with the associated safety switch

To maintain the level of safety, the actuators should only be purchased and used in combination with the associated safety switch. Assemble the position switch and actuator in such a way that the actuator can move into the actuator head within the insertion tolerance. Do not use position switches as an endstop.

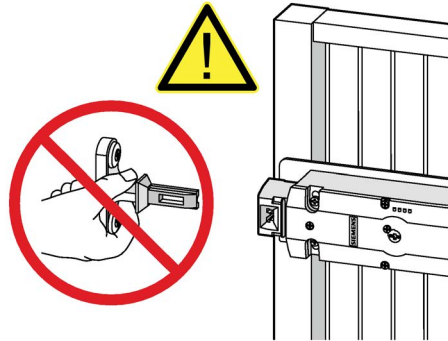

Note

Notes on interlocking devices in accordance with the DIN EN ISO 14119 standard

Observe the following notes from standard DIN EN ISO 14119 - 7.2:

Interlocking devices must be selected and/or installed so as to minimize defeat possibilities in a reasonably foreseeable way.

Measures for minimizing defeat possibilities of interlocking devices

- a) Prevent accessibility to the elements of the interlocking device
- b) Prevent substitute actuation of the interlocking device by means of easily available objects
- c) Prevent disassembly or position changing of elements of the interlocking device by means of non-removable fasteners (e.g. by welding, bonding, disposable screws, rivets, etc.)
- d) Prevent circumvention

! WARNING

Use of grounding bushings and jumper wires

Non-metallic enclosures do not provide an electrical connection between conduit unions. Proper grounding between metallic conduit unions must be established by using grounding bushings and jumper wires.

4.6 Mechanical safety switches with tumbler

Mechanical safety switches with tumbler and LED display

The safety switches with tumbler are available with an optional LED display. 2 LEDs on the front panel indicate the switch position of the interlock and the protective device.



Connection and LED display

NOTICE

Risk of property damage.

The voltage of the LEDs at the monitored contacts must match the operating voltage of the magnet (same potential).

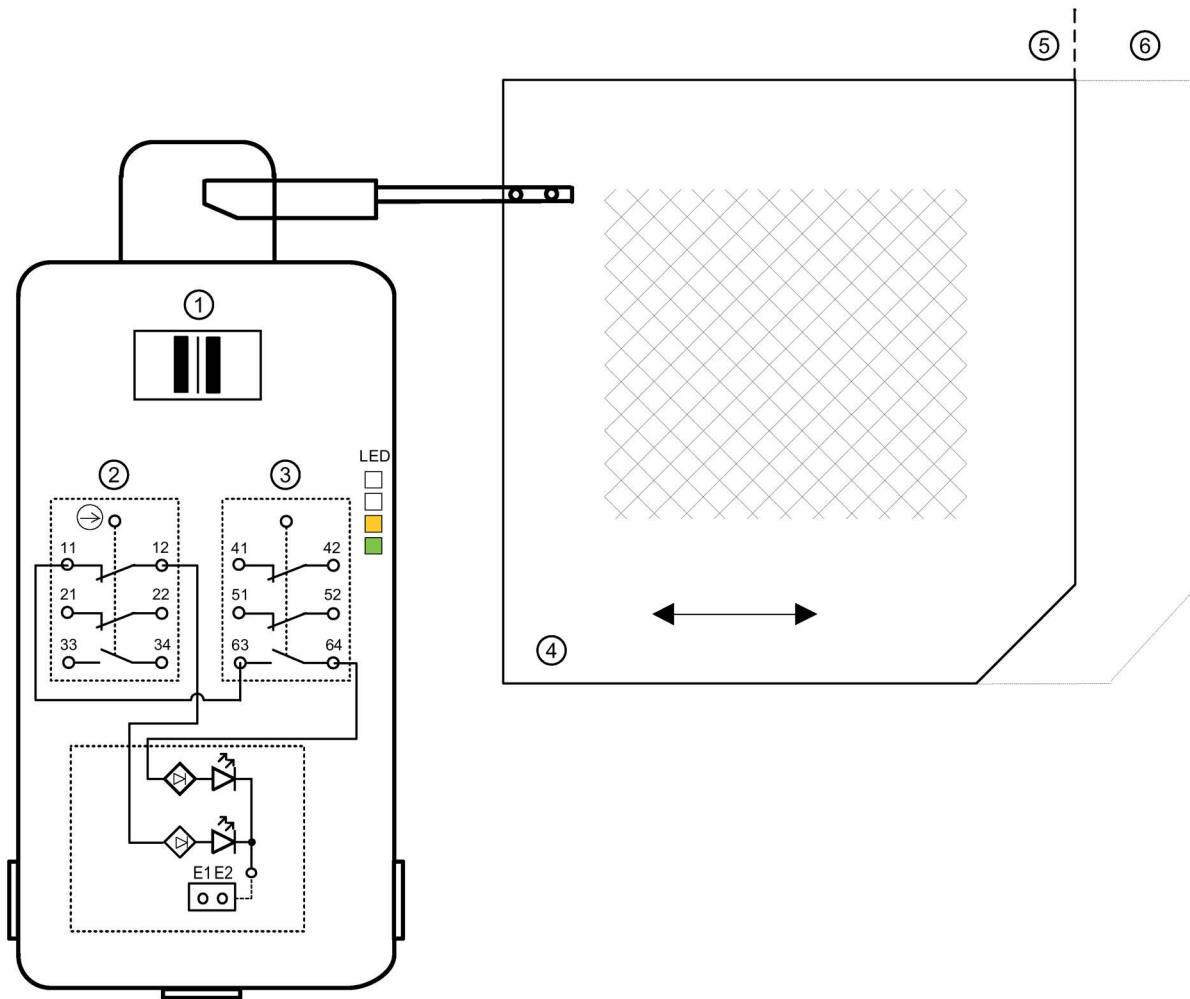

- ① Magnet
- ② Actuator monitoring
- ③ Magnet monitoring
- ④ Protective door
- ⑤ Protective door closed
- ⑥ Protective door open

Note

Internal wiring

- Stranded wires (red, green and yellow) are factory-wired.
- The voltage for LED actuation must be connected on site to terminal 11.
- The LED voltage must match the solenoid voltage.
- LED ground is wired internally to E2.

4.6 Mechanical safety switches with tumbler

| Protective device | Tumbler | Display | Meaning |
|-------------------|-------------|----------------------------|------------------------------|
| Closed | Released | ☀ yellow (A) + 🟢 green (B) | Actuator free for withdrawal |
| Closed | Interlocked | 🟢 green | Actuator interlocked |
| Open | Released | ☀ yellow | Actuator withdrawn |

4.6.5 Technical data for mechanical safety switches with tumbler

4.6.5.1 Technical data in Siemens Industry Online Support

Technical data sheet

You can also find the technical data of the product at Siemens Industry Online Support (<https://support.industry.siemens.com/cs/ww/en/ps/>).

1. Enter the full article number of the desired device in the "Product" field, and confirm with the Enter key.
2. Click the "Technical data link.

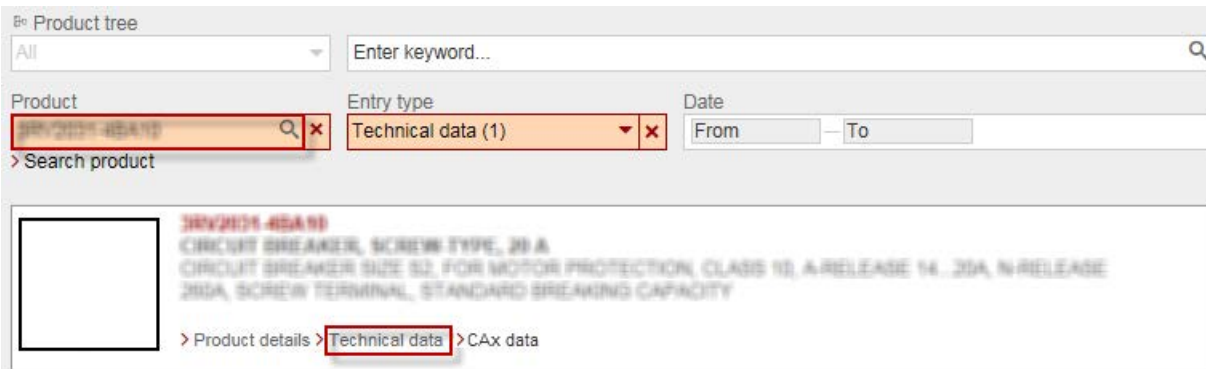

4.6.6 Maximum achievable safety category

| Function | Safety category |
|-----------|-----------------|
| Interlock | max. PLe/Cat. 3 |
| Tumbler | max. PLd/Cat. 2 |

4.6.7 Dimension drawings for mechanical safety switches with tumbler

| | |
|--|---|
| <p>Spring-locked, with front auxiliary release 3SE5322-.SD2., 3SE5322-.SG2., 3SE5322-.SJ2., 3SE5312-.SD1., 3SE5312-.SG1., 3SE5312-.SJ1.,</p> | <p>Spring-locked, with auxiliary release with lock 3SE5322-.SE2., 3SE5312-.SE1.</p> |
| | |
| <p>Spring-locked, with escape release 3SE5322-.SF2., 3SE5312-.SF1.</p> | <p>Solenoid-locked 3SE5322-.SB2., 3SE5312-.SB1.</p> |
| | |

4.6 Mechanical safety switches with tumbler

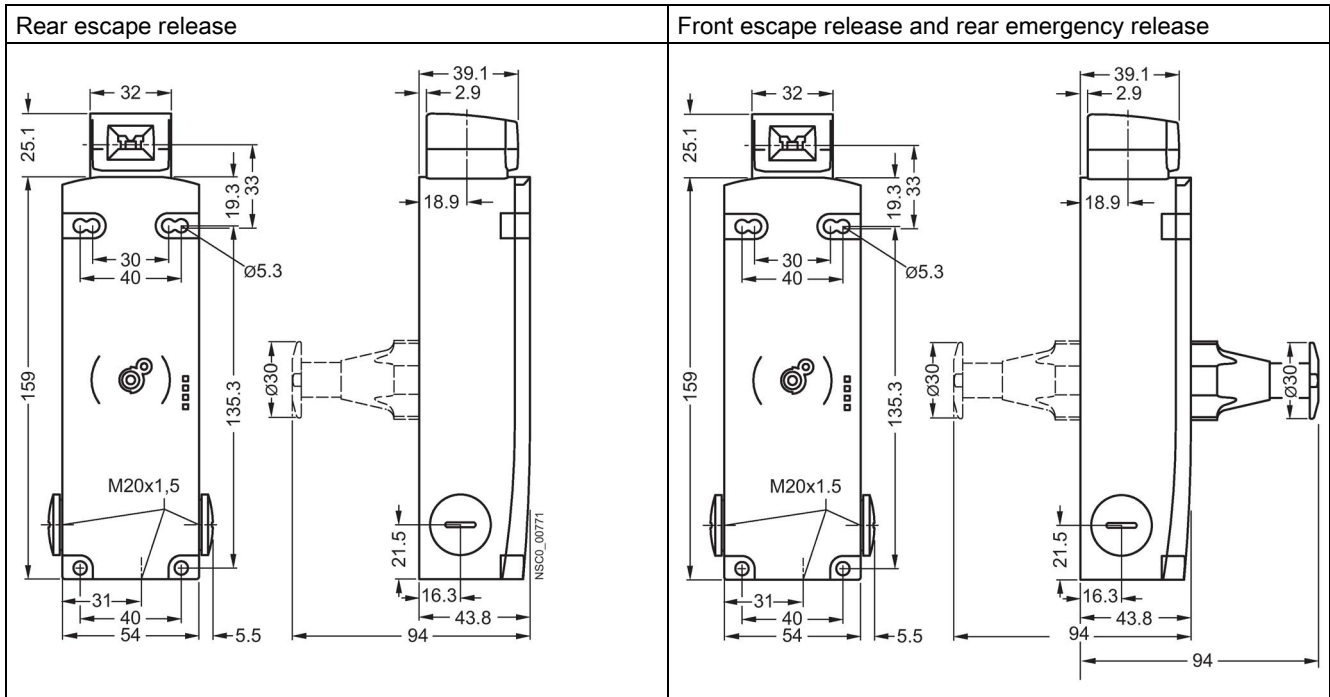

Note

The plastic enclosures have knock-outs behind the connecting thread; therefore, blind caps are not included in the scope of delivery.

4.7 Hinge switches



3SE5232-0.U21 3SE5232-0.U22 3SE5132-0LU21 3SE5132-0LU22 3SE2283

Application areas and features

- Used for hinged protective devices, such as doors or flaps, for which the position must be monitored for safety reasons.
- The position of the doors and flaps is converted to electrical signals with the hinge switch.
- With their low profile, the hinge switches can be fastened directly on a fixed frame.
- The hinge switches have snap-action contacts with an actuating angle of 10° and enable shutdown and signaling without delay at a small opening angle.

The 3SE5 hinge switches have the same enclosure as mechanical position switches (modular system).

The 3SE2283 hinge switches with built-in hinge are particularly suitable for use in doors and flaps of machines.

Benefits

- Fixed and positively-locking connections between the switch and protective door hinge directly at the pivot point of the protective device provide maximum protection from tampering and manipulation.
- Hinge switches in a standard enclosure according to EN 50047 and EN 50041 provide a small actuating angle of only 10°.
- The 1 NO/1 NC snap-action contacts enable simultaneous shutdown and signaling.
- 3SE2283 variants with a small operating angle of 4° or 8°.
- Protection against personal injury provided by positively driven NC contacts according to IEC 60947-5-1
- Simultaneous shutdown and reporting by 1 NO + 2 NC contacts

WARNING

Damage or wear. Functioning of the hinge switch may be detrimentally affected if this is not observed.

The complete switch must be replaced in the event of damage or wear. Replacement of individual parts or modules is not permitted.

4.7 Hinge switches

Enclosure sizes

The 3SE5 hinge switches are available as complete units in two enclosure sizes:

- Metal enclosure/plastic enclosure according to EN 50047, 31 mm wide, 1 cable entry
- Metal enclosure/plastic enclosure according to EN 50041, 40 mm wide, 1 cable entry

Enclosure versions

With the enclosures, you can choose from a variety of basic switches:

- Available with two-pole contact blocks, designed as snap-action contacts only.
- Available with three-pole contact blocks, designed as snap-action contacts only.

Actuator

The hinge switches are intended for mounting on hinges. The actuator head is included in the scope of delivery. There are two variants:

- Actuator with hollow shaft, inside diameter 8 mm, outside diameter 12 mm
- Actuator with solid shaft, diameter 10 mm

4.7.1 Notes on installation

4.7.1.1 Mounting 3SE5 hinge switches

Pay attention to the mounting instructions in chapter "Mechanical safety switches with tumbler" > "Notes on installation (Page 168)".

4.7.1.2 Mounting 3SE2283 hinge switches

1. / 2. Unscrew the cover of the plastic enclosure.
3. Use a hammer and a screwdriver to remove the pre-punched opening from the plastic enclosure of the hinge switch.
4. Screw the cable gland 3SX9926 onto the opening in the enclosure.

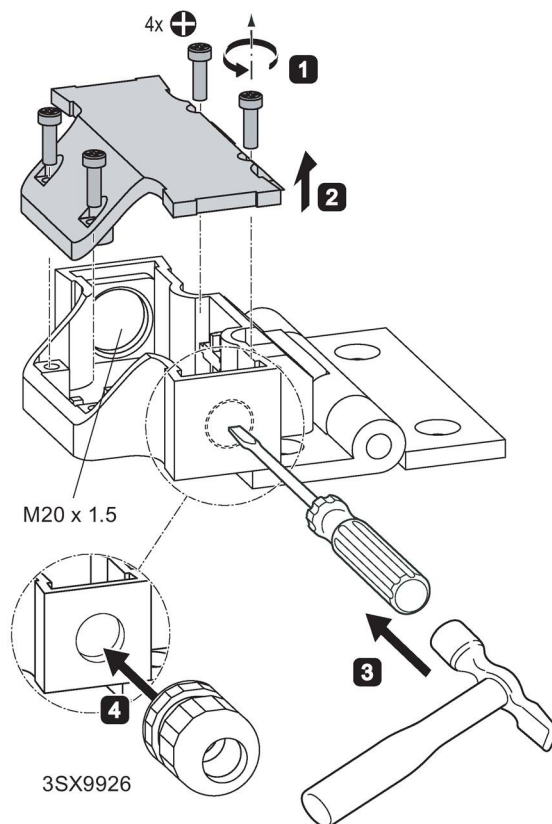

5. / 6. As illustrated, snap the contact block into the enclosure.
7. Fit the cover of the enclosure.
8. Fasten the cover of the enclosure with 4 cross-recessed screws.

4.7 Hinge switches

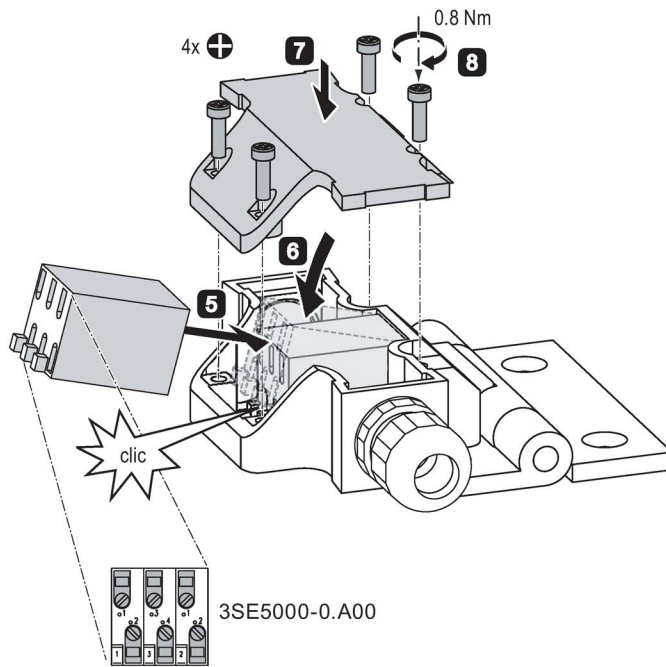

! WARNING
 Damage or wear. Functioning of the hinge switch may be detrimentally affected if this is not observed.
 The complete switch must be replaced in the event of damage or wear. Replacement of individual parts or modules is not permitted.

Mounting instructions

NOTICE
 Observe the operating angle.
 On installation, make sure that the hinge of the hinge switch has an operating angle of 4 ° to 8 °.

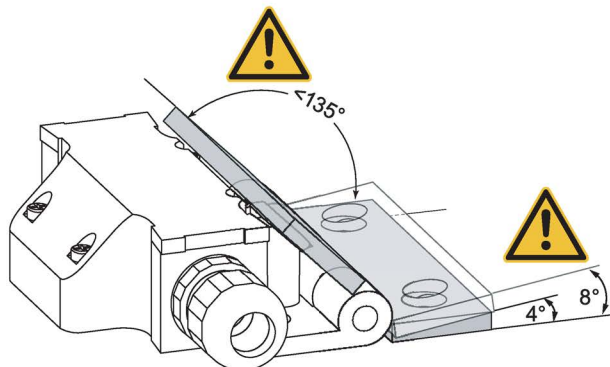

| 4° | 8° |
|---------------|---------------|
| 3SE2283-0GA43 | 3SE2283-0GA53 |
| 3SE2283-6GA43 | 3SE2283-6GA53 |
| 3SE2283-6GA44 | |
| 3SE2283-6GA44 | |

4.7.2 Technical data for hinge switches

4.7.2.1 Technical data in Siemens Industry Online Support

Technical data sheet

You can also find the technical data of the product at Siemens Industry Online Support (<https://support.industry.siemens.com/cs/ww/en/ps/>).

1. Enter the full article number of the desired device in the "Product" field, and confirm with the Enter key.
2. Click the "Technical data link."

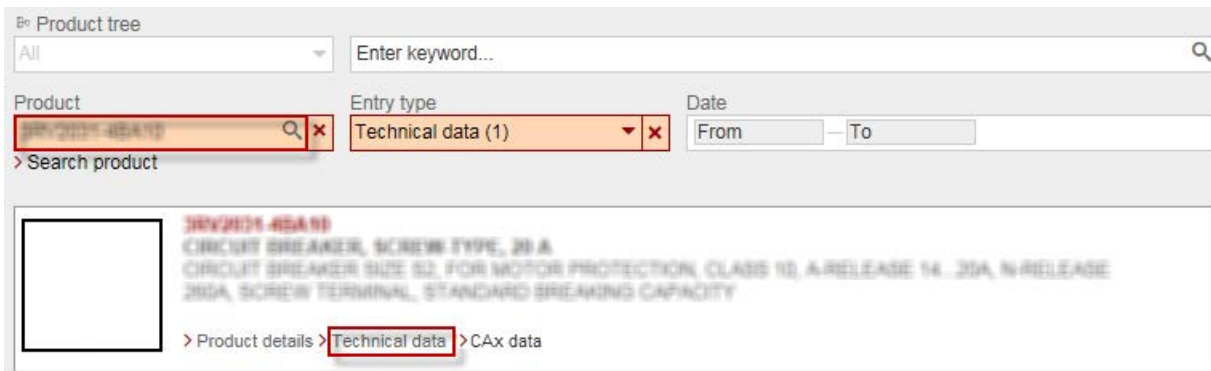

4.7.3 Dimension drawings and operating travel diagrams

Dimension drawings for 3SE5 hinge switches

| Enclosure width 31 mm with hollow shaft 3SE5212-0.U21 3SE5232-0.U21 | Enclosure width 31 mm with solid shaft 3SE5212-0.U22 3SE5232-0.U22 |
|---|--|
| | |

4.7 Hinge switches

| | |
|---|--|
| Enclosure width 40 mm with hollow shaft 3SE5112-0.U21 3SE5132-0.U21 | Enclosure width 40 mm with solid shaft 3SE5122-0.U22 3SE5132-0.U22 |
| | |

Operating travel diagrams for 3SE5 hinge switches

| Snap-action contacts | |
|-----------------------------------|-----------------------------------|
| 1 NO + 1 NC Code number 11 | 1 NO + 2 NC Code number 12 |
| 3SE5...-0HU2. | 3SE5...-0LU2. |

- ⊕ → Positive opening operation according to EN 60947-5-1
- Direction of actuation
- Contact element closed
- Contact element open

Dimension drawings for 3SE2 hinge switches

| | |
|---|--|
| <p>Hinge switch, molded-plastic enclosure with hinge 3SE2283-.GA4 /-.GA5.</p> | <p>Additional hinge for 40 mm profile for hinge switch 3SX3225 / 3SX3231</p> |
| | |

4.7 Hinge switches

Operating travel diagrams for 3SE2283

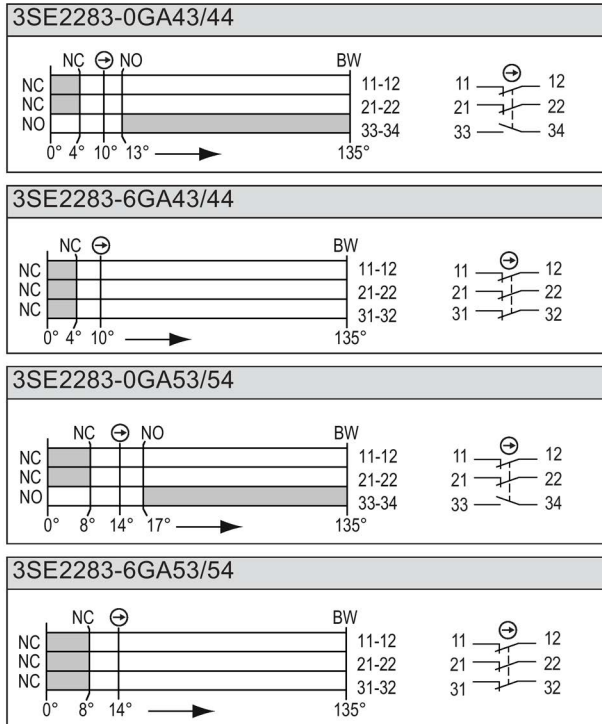

- NC NC contact
- NO NO contact
- ⊕ Positive opening operation according to EN 60947-5-1
- BW Actuator travel
- Contact element closed
- Contact element open

4.8 Magnetically operated switches

4.8.1 3SE66/3SE67 non-contact magnetically operated safety switches



A magnetically operated switch comprises a coded switching magnet and a contact block (sensor unit). Evaluation requires a safety relay or connection to a bus system.

A magnetic monitoring system comprises one or more magnetically operated switches and an evaluation unit, e. g. a safety relay (3SE6806-2CD00, 3SK1) (see Chapter Safety relays (Page 224)).

Application areas and features

- On movable protective guards (hoods, hinge switches, doors, etc.)
- The closed design with IP67 degree of protection is particularly suitable therefore for areas exposed to contamination, cleaning or disinfecting.
- When magnetically operated switches with 1 NO + 1 NC / 2 NC contact blocks are used, the safety relays provide a high level of protection against manipulation and can be installed in safety circuits up to SIL 3 according to EN ISO 13849-1.

4.8 Magnetically operated switches

4.8.1.1 Mounting position for 3SE66 magnetically operated switches

Adjustment

Only 3SE67 coded magnets can be used to operate the 3SE66 contact blocks.

Note

Function check

Please always check proper operation of the magnetic monitoring system with the connected monitoring unit.

Use the specified diagrams to perform adjustment. When the center marking of the magnet is within the depicted basic setting zone, the connected monitoring unit will provide an enable signal. The specified operating distances refer to switches and magnets mounted opposite. In principle, other arrangements are possible, but they may lead to different operating distances.

| |
|---|
| NOTICE |
| Keep to the mounting distance. |
| When fitting two systems, pay attention to a mounting distance of at least 50 mm. |

Round contact block, 3SE6605-1BA

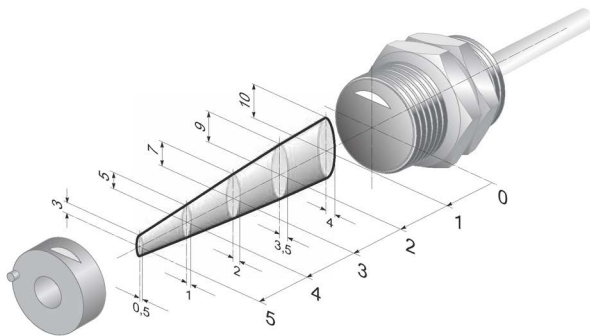

$s_{ao} = 5 \text{ mm}$
 $s_{ar} = 15 \text{ mm}$

s_{ao} = safe operating distance ON
 s_{ar} = safe operating distance OFF

Rectangular contact block, 25 x 88 mm, 3SE6604-2BA/3SE6605-2BA

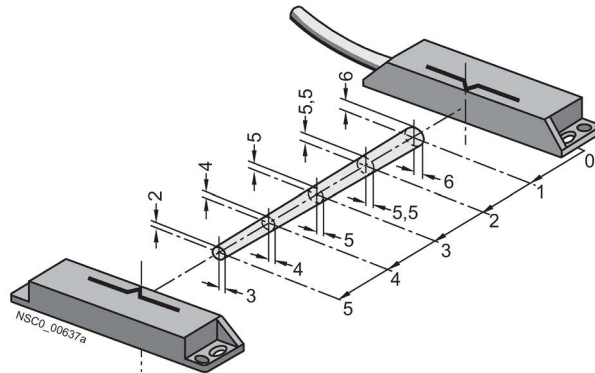

Rectangular contact block, 25 x 33 mm, 3SE6605-3BA/3SE6606-3BA

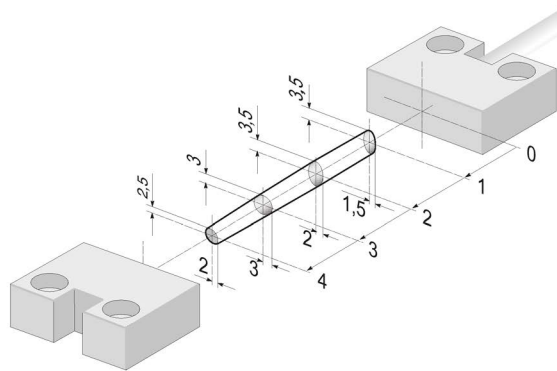

$s_{ao} = 4 \text{ mm}$
 $s_{ar} = 14 \text{ mm}$

s_{ao} = safe operating distance ON

s_{ar} = safe operating distance OFF

Note

EN 60947-5-3

The EN 60947-5-3 standard is fulfilled only by a complete system comprising the contact block, the coded switching magnet, the monitoring unit (electronics; e.g. 3SK) or AS-i Safe and SIMATIC S7300F.







Note

Lateral actuation

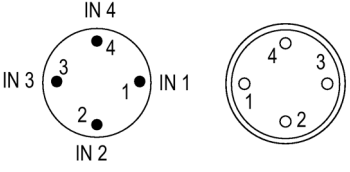
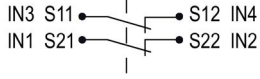
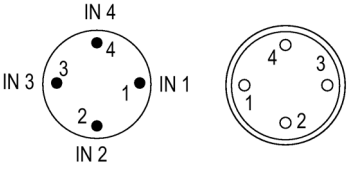
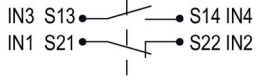
Lateral actuation of the safety sensor (sliding door) via the longitudinal side of the safety sensor is allowed only from the direction opposite the cable outlet.

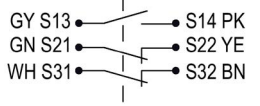
4.8 Magnetically operated switches

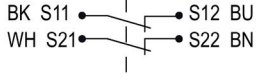
4.8.1.2 3SE660 pin assignments

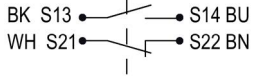
| | | |
|---|--|--|
| <p>4-pole with plug (2 NC)</p>  | <p>3SE6604-2BA01</p> |  |
| <p>4-pole with plug (1 NO + 1 NC)</p>  | <p>3SE6605-1BA02 / 3SE6605-2BA01</p> |  |
| <p>6-pole with cable (1 NO + 2 NC)</p>  | <p>3SE6606-2BA04 / 3SE6606-3BA</p> |  |
| <p>4-pole with cable (2 NC)</p>  | <p>3SE6604-2BA / 3SE6604-2BA10</p> |  |
| <p>4-pole with cable (1 NO + 1 NC)</p>  | <p>3SE6605-1BA / 3SE6605-1BA25 / 3SE6605-2BA / 3SE6605-2BA10 / 3SE6605-3BA / 3SE6606-3BA05 / 3SE6605-3BA10 / 3SE6605-3BA15 / 3SE6605-3BA25</p> |  |

| | |
|------------|-------------|
| GY = gray | PK = pink |
| GN = green | YE = yellow |
| WH = white | BN = brown |
| BK = black | BU = blue |

Connection of 3SE6606-3BA

| | 3SE6606-3BA |
|--------------------|---|
| Safety contacts | S21-S22 and S13-S14 |
| Signaling contacts | S31-S32 |
| NO contact | S13-S14 at the NO contact input of the safety evaluation unit |
| NC contact | S21-S22 at the NC contact input of the safety evaluation unit |
| | S31-S32 is exclusively a signaling contact |

4.8.1.3 Notes on installation

Installation

By laying the cables between the magnetically-operated switch and the evaluation unit in a manner that protects them against short-circuit, the occurrence of a cross-circuit fault can be excluded.

Note the following for installation of the magnetically-operated switch:

- When using the magnetically-operated switches on the following Siemens evaluation units, no protected laying of cables or fuse protection is required:
 - Magnetically-operated switch evaluation unit 3SE6806-2CD00
 - 3SK112 Advanced safety relays as well as 3SK122 input expansions
 - 3SK2 safety relays
 - 3RK3 Modular Safety System MSS
- If none of the evaluation units listed above is used, the cables between the magnetically-operated switch and the evaluation unit must be laid such that they are short-circuit and cross-circuit-proof in order to prevent contact welding in the event of a cross circuit.
- If the protected laying of cables is not possible, then every channel in the sensor circuit must be protected:
 - G fuse links: 0.25 A 250 V/AC very-fast-acting (FF) 5 x 20 mm for Standard 3SE66 magnetically-operated switches.
 - Magnetically operated switches with LED display (3SE66..-4....) are not able to be used in this case due to the reduced operating current.
 - Use the fuse terminal with plug-in connection 8WH6000-1GG08, with cover 8WH9003-1GA00, or the fuse terminal with screw connection 8WA1011-1SF12 to secure the fuse on a DIN rail.

Regular technical tests

Perform regular checks to ensure fault-free and reliable operation.

Test the safe functioning of the protective equipment in the following cases:

- after every commissioning operation
- every time a component is replaced
- after an extended period of non-operation or standstill
- after every fault

Test the safe function of the protective equipment at suitable intervals, such as during maintenance activities. Refer to the EN ISO 14119 standard for examples of possible intervals.

4.8 Magnetically operated switches

4.8.1.4 Technical data for 3SE660 magnetically-operated switches

Technical data in Siemens Industry Online Support

Technical data sheet

You can also find the technical data of the product at Siemens Industry Online Support (<https://support.industry.siemens.com/cs/ww/en/ps/>).

1. Enter the full article number of the desired device in the "Product" field, and confirm with the Enter key.
2. Click the "Technical data link."

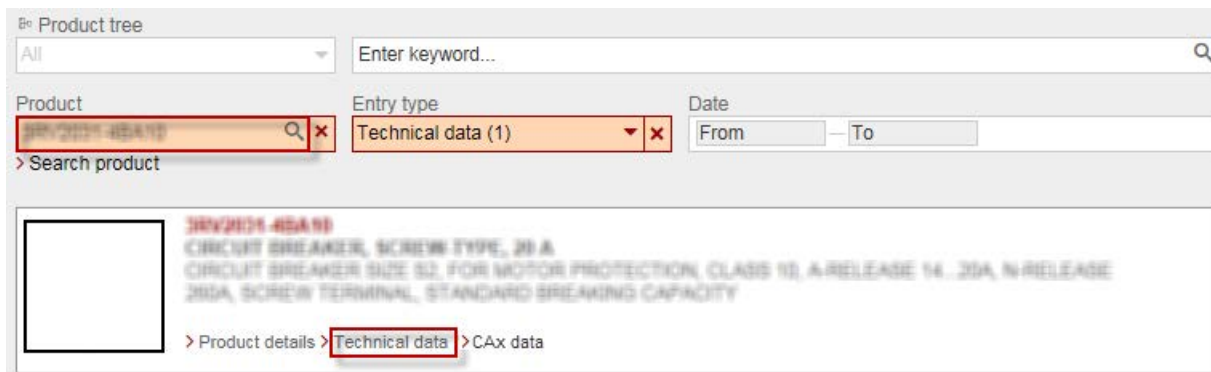

4.8.1.5 Dimension drawings for magnetically operated switches and contact blocks

Round contact block with cable, 3SE6605-1BA / 3SE6605-1BA25

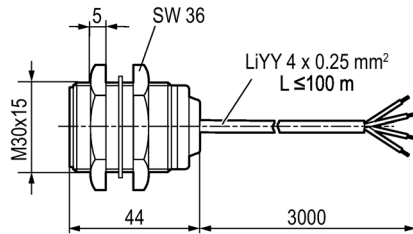

Round contact block with M12 plug, 3SE6605-1BA02

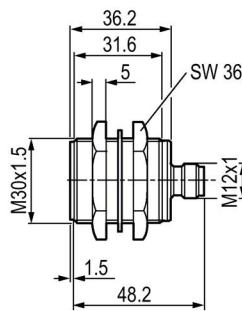

Rectangular contact block, 25 x 88 mm, with cable, 3SE6604-2BA / 3SE6605-2BA, 3SE6604-2BA10 / 3SE6605-2BA10, 3SE6605-2BA05

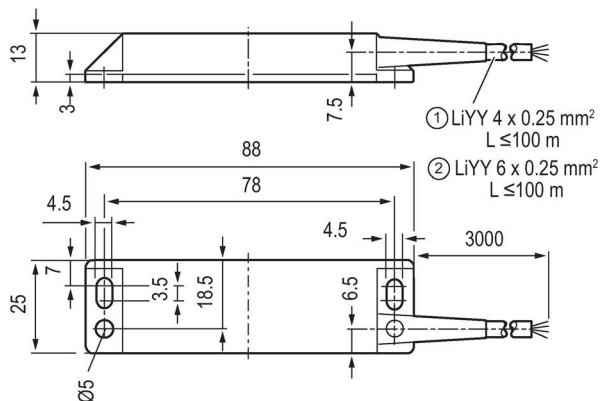

Rectangular contact block, 25 x 88 mm, with M12 plug, 3SE6604-2BA01 / 3SE6605-2BA01

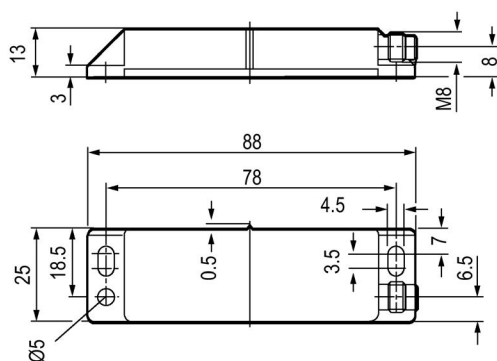

Rectangular contact block, 25 x 33 mm, with cable, 3SE6605-3BA / 3SE6606-3BA

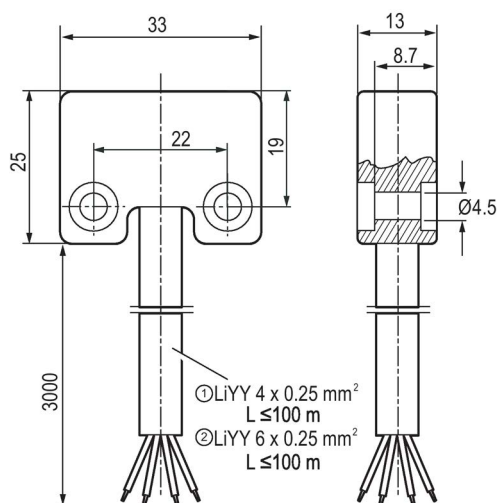

Rectangular contact block,, 25 x 33 mm with M12 plug, 3SE6605-3BA03

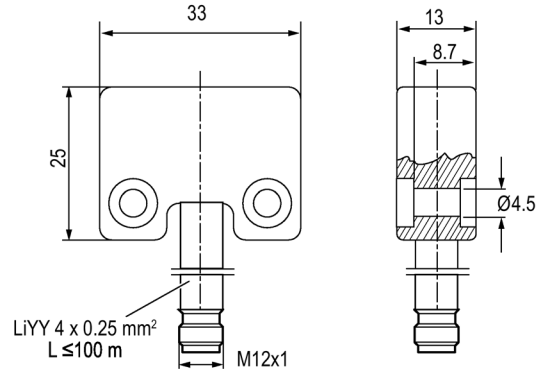

4.8.1.6 Dimension drawings of switching magnets

Round switching magnet, 3SE6704-1BA

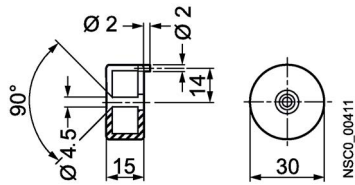

Rectangular switching magnet, 3SE6704-2BA

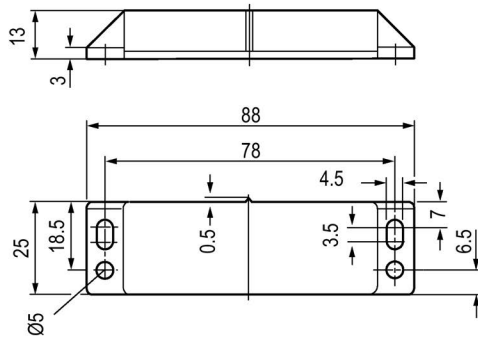

4.8 Magnetically operated switches

Rectangular switching magnet, 3SE6704-3BA

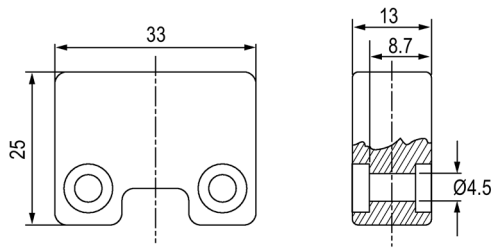

4.8.1.7 Dimension drawings of spacers

Spacer accessory, 3SX3260

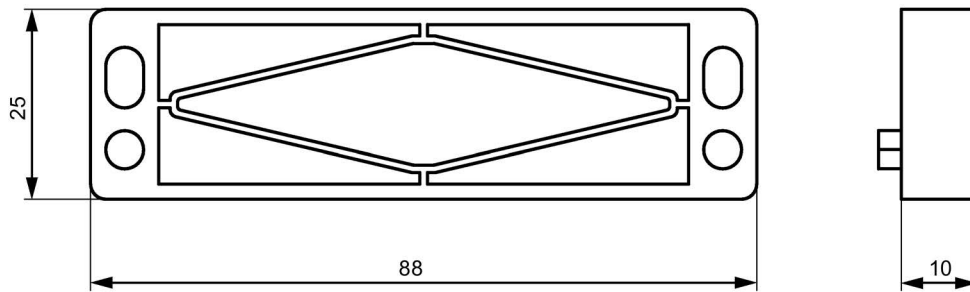

Spacer accessory, 3SX3261

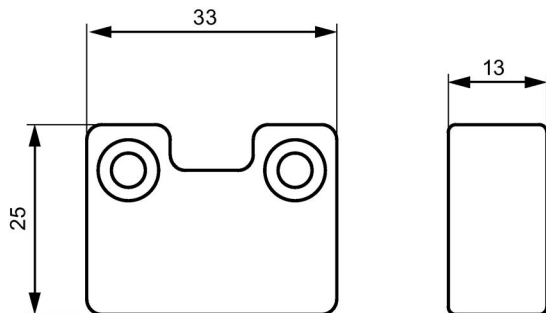

4.8.1.8 Example circuits

Example circuit 3SE6604 with SIRIUS 3SK11 safety relay

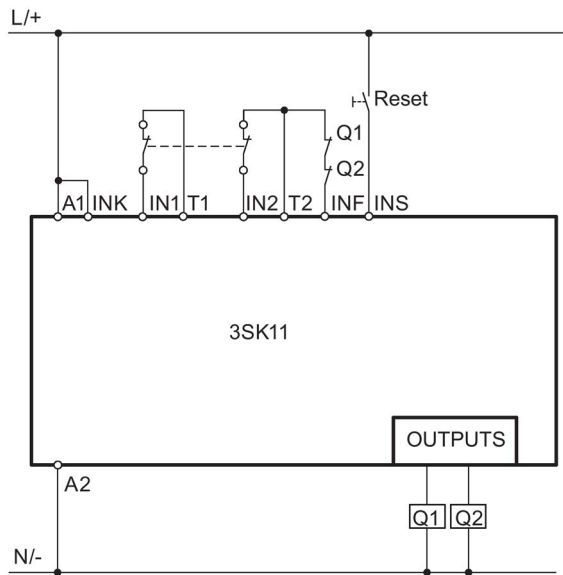

Achievable safety level: PLe (DIN EN ISO 13849-1), SIL3 (EN 62061)

Example circuit 3SE6605 / 3SE6606 with SIRIUS 3SK112 safety relay

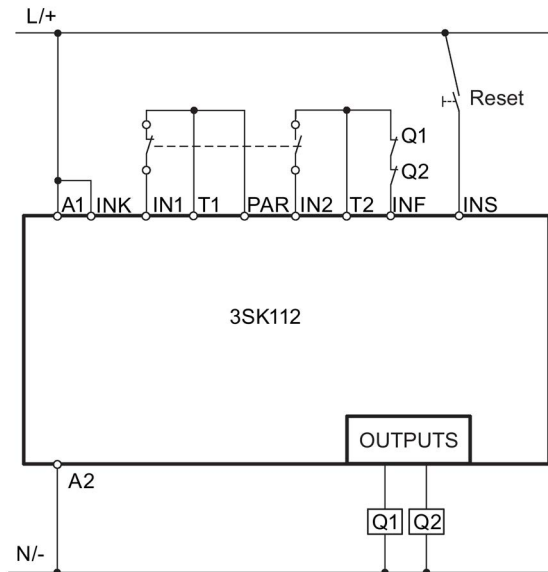

Achievable safety level: PLe (DIN EN ISO 13849-1), SIL3 (EN 62061)

4.8 Magnetically operated switches

4.8.2 3SE661 / 3SE662 non-contact magnetically operated safety switches



Application areas and features

- The 3SE66 safety sensors for use in safety circuits serve to monitor the positions of movable protective devices in compliance with DIN EN ISO 14119 and IEC 60947-5-3.
- Only 3SE67 actuators may be used to operate the 3SE66 safety sensors.
- The closed design with IP67 degree of protection is particularly suitable therefore for areas exposed to contamination, cleaning or disinfecting.
- When magnetically operated switches with 1 NO + 1 NC (+ 1 NC = signaling contact) / 2 NC (+ 1 NC = signaling contact) contact blocks are used, the 3SE6806 and 3SK safety relays provide a high level of protection against manipulation and can be installed in safety circuits up to SIL 3 according to EN ISO 13849-1.

Note





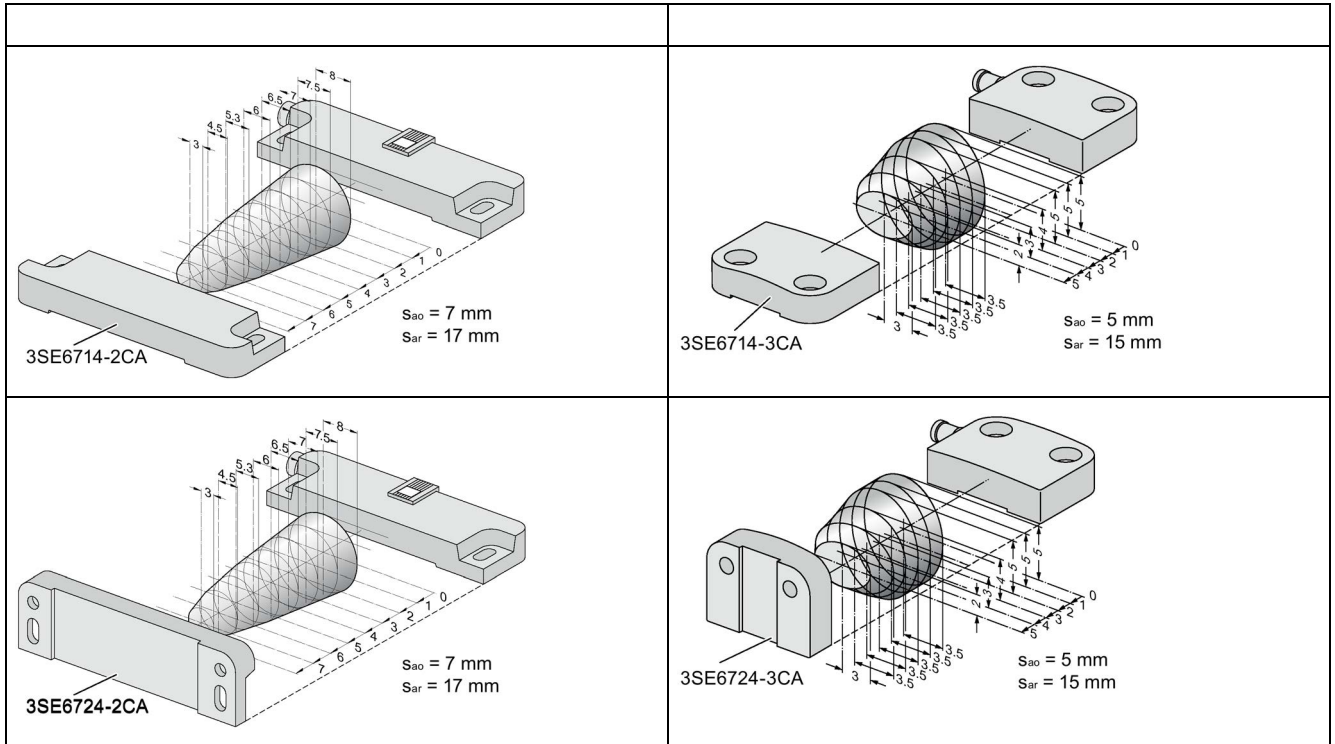





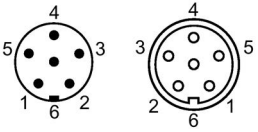

The safety sensors are used in applications in which the hazardous state is ended without delay when the protective device is opened.

4.8.2.1 Mounting position

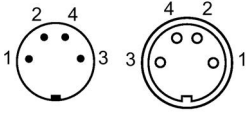

4.8 Magnetically operated switches

4.8.2.2 Pin assignments

| | | |
|---|---|---|
| <p>6-pole with plug</p>  | <p>3SE6617-2CA01 / 3SE6627-2CA01 3SE6617-3CA01 / 3SE6627-3CA01</p> <hr/> <p>3SE6616-3CA01 / 3SE6626-3CA01</p> | <p>(3) S11  S12 (4) (1) S21  S22 (2) (5) S31  S32 (6)</p> <hr/> <p>(3) S13  S14 (4) (1) S21  S22 (2) (5) S31  S32 (6)</p> |
| <p>4-pole with plug</p>  | <p>3SE6614-4CA01 / 3SE6624-4CA01</p> | <p>(3) S11  S12 (4) (1) S21  S22 (2)</p> |
| <p>6-pole with cable</p>  | <p>3SE6617-2CA04 / 3SE6627-2CA04 3SE6617-3CA04 / 3SE6627-3CA04</p> | <p>(GY) S11  S12 (PK) (GN) S21  S22 (YE) (WH) S31  S32 (BN)</p> |

GY = gray PK = pink S11/12, S13/14, S21/22 = safety contact
 GN = green YE = yellow S31/32 = signaling contact
 WH = white BN = brown

4.8.2.3 Technical data for 3SE661 / 3SE662 magnetically-operated switches

Technical data in Siemens Industry Online Support

Technical data sheet

You can also find the technical data of the product at Siemens Industry Online Support (<https://support.industry.siemens.com/cs/ww/en/ps/>).

1. Enter the full article number of the desired device in the "Product" field, and confirm with the Enter key.
2. Click the "Technical data link."

The screenshot shows the Siemens Industry Online Support search interface. At the top, there is a search bar with the text "Enter keyword...". Below the search bar, there are three filters: "Product" with the value "3RV2015-4BA10", "Entry type" with the value "Technical data (1)", and "Date" with "From" and "To" fields. Below the filters, there is a search button labeled "> Search product". The search results are displayed in a table with one entry for the product "3RV2015-4BA10". The entry includes a small image of the product and the following text: "CIRCUIT BREAKER, SCREW TYPE, 20 A, CIRCUIT BREAKER SIZE S2, FOR MOTOR PROTECTION, CLASS 10, A-RELEASE 14, 20A, N-RELEASE 20SA, SCREW TERMINAL, STANDARD BREAKING CAPACITY". Below the text, there are three links: "> Product details", "> Technical data", and "> CAx data".

Note

LED status display

In the version with the LED display, the LED lights up when the protective door is closed.

4.8 Magnetically operated switches

4.8.2.4 Dimension drawings

| Contact blocks and switching magnets, 25 x 88 mm | |
|---|--|
| <p>Contact block 3SE6614-4CA01, door hinge left</p> | <p>Contact block 3SE6624-4CA01, door hinge right</p> |
| | <p>Contact block 3SE6627-2CA01, door hinge right</p> |

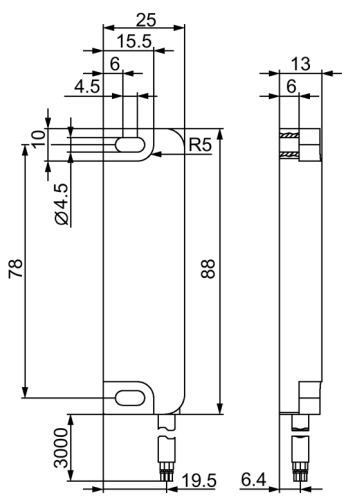
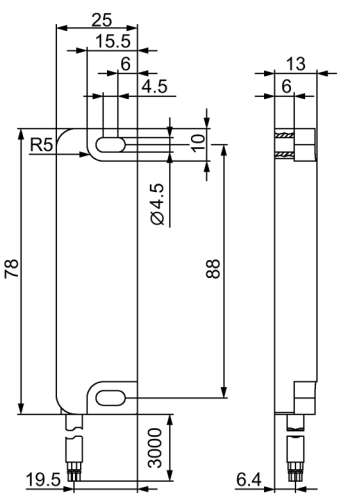
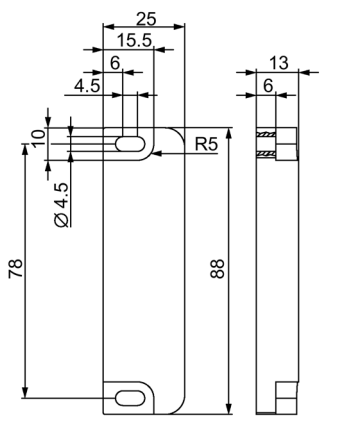
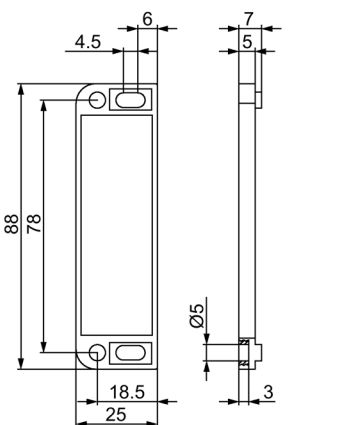
| Contact blocks and switching magnets, 25 x 88 mm | |
|---|---|
|  <p>Contact block 3SE6617-2CA04, door hinge left</p> |  <p>Contact block 3SE6627-2CA04, door hinge right</p> |
|  <p>Switching magnet 3SE6714-2CA, position with contact block in one mounting plane</p> |  <p>Spacer 3SX5600-2GA02</p> |

4.8 Magnetically operated switches

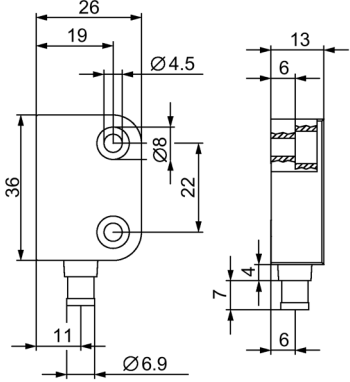
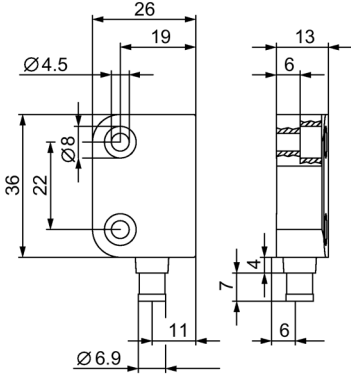
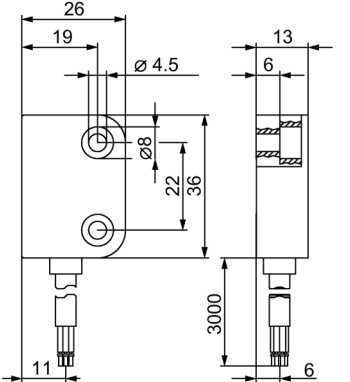
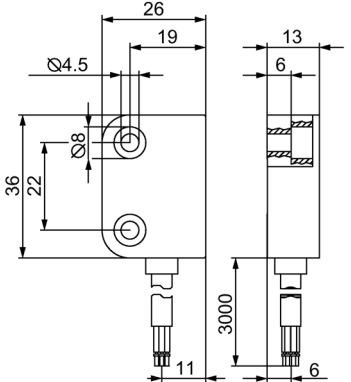
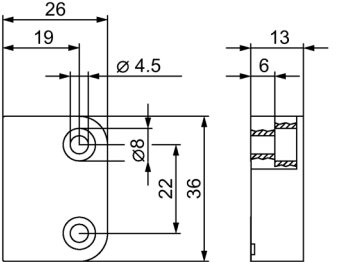
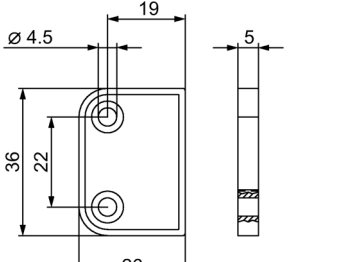
| | |
|--|--|
| <p>Contact blocks and switching magnets, 26 x 36 mm</p>  <p>Contact block 3SE6617-3CA01, door hinge left</p> |  <p>Contact block 3SE6626-3CA01, door hinge right</p> |
|  <p>Contact block 3SE6617-3CA04, door hinge left</p> |  <p>Contact block 3SE6627-3CA04, door hinge right</p> |
|  <p>Switching magnet 3SE6714-3CA, position with contact block in one mounting plane</p> |  <p>Spacer 3SX5600-2GA01</p> |

4.8.3 Notes on installation

Installation position

Any installation position is possible, but the actuation surfaces must be parallel with one another.

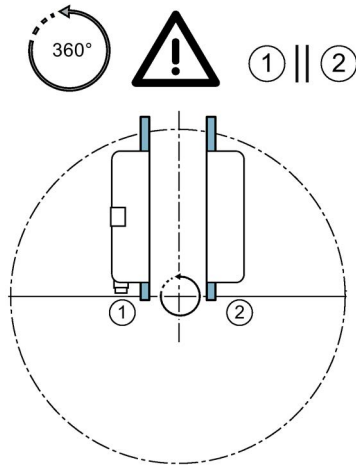

Mounting distance

The mounting distance between two systems is at least 50 mm.

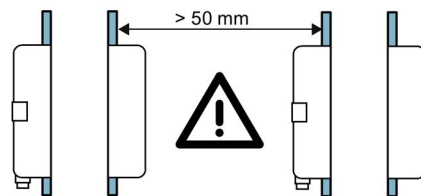

Ambient conditions

Do not subject the safety sensor and the actuator to extreme vibrations and impacts.

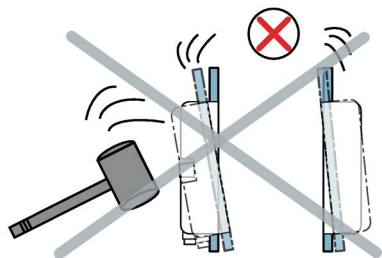

Be sure to keep the safety sensor and the actuator free from iron swarf.

Installation

Do not use the safety sensor and the actuator as endstops.

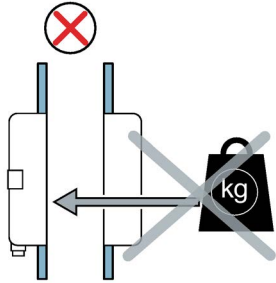

Mounting and checking

The safety sensor may only be mounted onto flat surfaces because distortion can otherwise occur that is capable of destroying the sensor or changing the minimum distances.

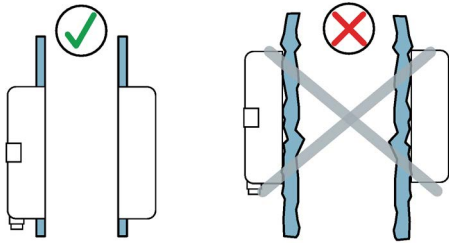

The safety sensor and the actuator must be mounted inseparably on the protective device.

Check the operating capability of the safety sensor and the actuator once a year.

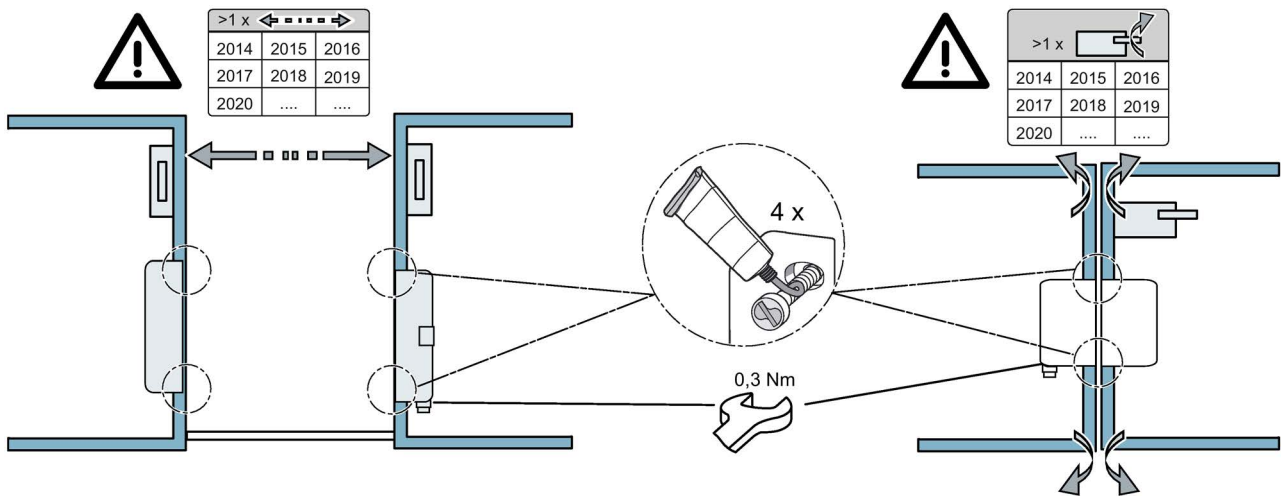

Magnetic influences

Note

The safety sensor and the actuator must not be fitted in strong magnetic fields in order to ensure their proper function.

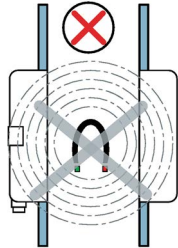

If the safety sensor and the actuator are to be fitted on magnetic material, a 5 mm thick non-magnetic adapter or the original spacer must be used.

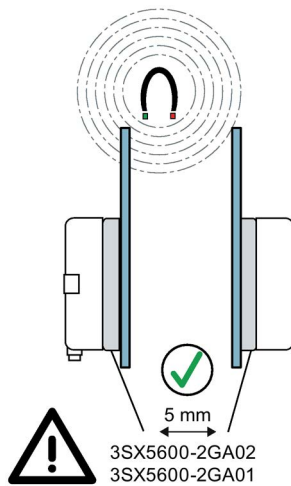

Use non-magnetic screws for mounting only.

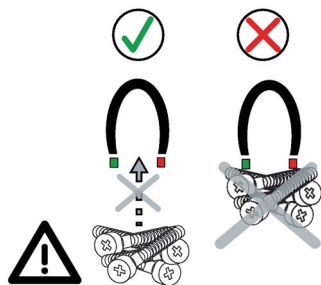

4.8 Magnetically operated switches

4.8.4 Magnetically operated switch - monitoring unit combination

| Monitoring units | | Magnetically operated switches (contact block + switching magnet) | | | Achievable SIL (IEC 61508, IEC 62061) Performance Level (EN ISO 13849-1) |
|--------------------------------------|-------------------|--|--|---|--|
| | | 1 NO + 1 NC 3SE6605-.BA.. 1 NO + 1 NC (+ 1 NC signaling contact) 3SE6606-3BA 3SE6704-.BA | 2 NC 3SE6604-2BA.. 1 NO + 2 NC 3SE6606-2BA04 3SE6704-2BA | – | |
| Relay outputs | | | | | |
| SIRIUS safety relays | 3SK1111 | -- | ✓ | ✓ | SIL 3/PL e |
| | 3SK1121, 3TK2826 | ✓ | ✓ | ✓ | SIL 3/PL e |
| Solid-state output | | | | | |
| SIRIUS safety relays | 3SK1112, 3SK1122 | ✓ | ✓ | ✓ | SIL 3/PL e |
| | 3SK2112, 3SK2122 | ✓ | ✓ | ✓ | SIL 3/PL e |
| | 3TK2845 | -- | ✓ | ✓ | SIL 3/PL e |
| ASIsafe compact safety modules | 3RK1205, 3RK1405 | -- | ✓ | ✓ | SIL 3/PL e |
| Modular Safety System (MSS) | 3RK3 | ✓ | ✓ | ✓ | SIL 3/PL e |
| SIMATIC S7-1200F or SIMATIC S7-1500F | F-DI 16 x 24 V DC | ✓ | ✓ | ✓ | SIL 3/PL e |
| SIMATIC ET 200SP PROFIsafe | 4/8 F-DI, 24 V DC | ✓ | ✓ | ✓ | SIL 3/PL e |

| Monitoring units | | Magnetically operated switches (contact block + switching magnet) | | | Achievable SIL (IEC 61508, IEC 62061) Performance Level (EN ISO 13849-1) |
|-------------------|---|--|--|----|--|
| | | 1 NO + 1 NC 3SE6605-.BA.. 1 NO + 1 NC (+ 1 NC signaling contact) 3SE6606-3BA 3SE6704-.BA | 2 NC 3SE6604-2BA.. 1 NO + 2 NC 3SE6606-2BA04 3SE6704-2BA | -- | |
| SIMATIC ET 200eco | 4/8 F-DI, 24 V DC | ✓ | ✓ | ✓ | SIL 3/PL e |
| SIMATIC ET 200pro | 8/16 F-DI, 24 V DC, 4/8 F-DI / 4 F-DO 2 A, 24 V DC, F-Switch | ✓ | ✓ | ✓ | SIL 3/PL e |

✓ Suitable magnetically operated switch

-- Not available

4.9 3SF1 mechanical safety switches for AS-Interface

SIRIUS detection devices are ideally suited as the basis for networked systems within a plant.

The individual components can be integrated into the AS-Interface system.

They are fully compatible according to IEC 62026-2 with the well-known AS-Interface components, e.g., master, slaves, power supply unit, etc., and can be connected to the same yellow AS-Interface cable. We supply all components for configuring a safe AS-Interface network.

- The entire range of 3SE5 position switches is available with integrated ASIsafe electronics:
 - Mechanical position switches
 - Mechanical safety switches with separate actuator
 - Mechanical safety switches with tumbler
- The connection to the AS-Interface system is made via an M12 connector
- Because the safety switches with tumbler are directly integrated into the AS-i network, the load on the data cable is very low. The maximum current consumption of the magnet is 170 mA.

4.9.1 Overview

The SIRIUS 3SF1 mechanical safety switches with safety-related communication can be directly connected via the AS-Interface bus system. As a result, the safety functions no longer have to be conventionally wired.

The ASIsafe electronics are integrated within the switch enclosure in 3SF1 safety switches.





Figure 4-13 Examples of possible selections in the modular system

4.9.2 Modular system

The safety switches of the 3SF11.4 and 3SF12.4 series are configured as a modular system, consisting of the basic enclosure in different variants and an actuator, which must be ordered separately. The modular switch design allows the end user to choose the appropriate solution from a wide selection of variants and to quickly assemble it himself. The 3SF1 safety switches have the same enclosure as the mechanical position switches.

4.9.3 LED display

The switches have a display with three LEDs:

| Status display (operating status) | | | |
|-----------------------------------|--|--|---|
| LED | LED 1 (F-IN1) | LED 2 (F-IN2) | LED 3 AS-i/Fault |
| |  yellow |  yellow |  green/red |

4.9 3SF1 mechanical safety switches for AS-Interface

4.9.4 Plug connection

The connection to the AS-Interface is made via a 4-pin M12 plug connector (plastic version) to the yellow AS-Interface bus cable.

The 50 mm and 56 mm-wide enclosures also have an M12 socket for connecting a second position switch. As a result, category 4 according to ISO 13849-1 (EN 954-1) or SIL2/SIL3 according to IEC 61508 is achieved.

4.9.5 Mounting

Pay attention to the mounting instructions in chapter Mechanical safety switches with tumbler > Notes on installation (Page 168).

4.9.6 Technical data for safety switches for AS-Interface

4.9.6.1 Technical data in Siemens Industry Online Support

Technical data sheet

You can also find the technical data of the product at Siemens Industry Online Support (<https://support.industry.siemens.com/cs/ww/en/ps/>).

1. Enter the full article number of the desired device in the "Product" field, and confirm with the Enter key.
2. Click the "Technical data link."

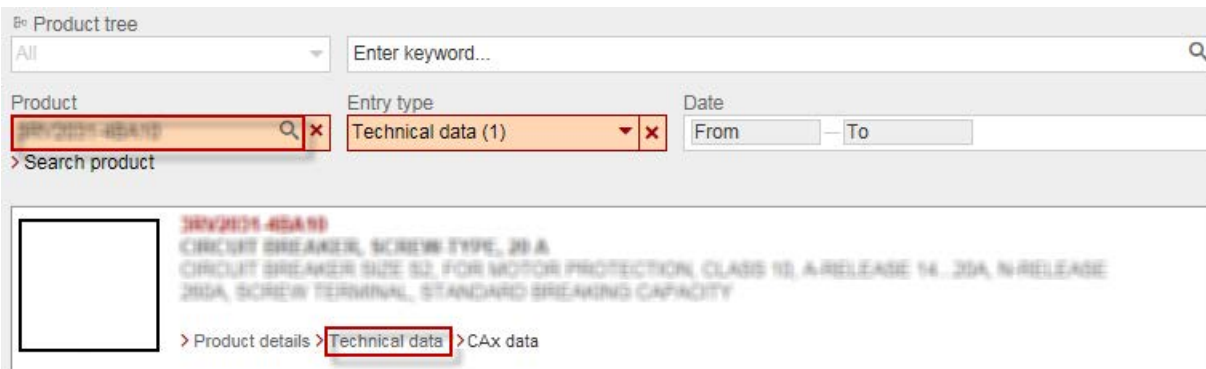

| | |
|---|----------------------|
| Data according to AS-Interface Specification | 3SF11 / 3SF12 |
| I/O configuration | 7 / B |
| ID1 code/ID2 code (hex) | F / F |

4.9.7 Dimension drawings for safety switches for AS-Interface

Basic switches (without actuator)

Enclosure width 31 mm, EN 50047
3SF1234

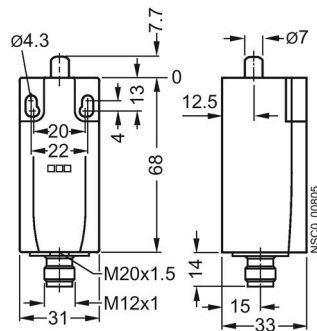

Enclosure width 50 mm
3SF1244

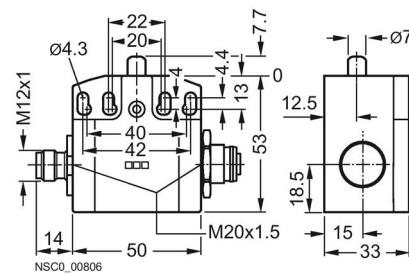

Enclosure width 40 mm, EN 50041
3SF1114

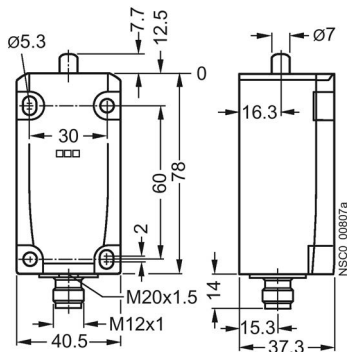

Enclosure width 56 mm
3SF1124

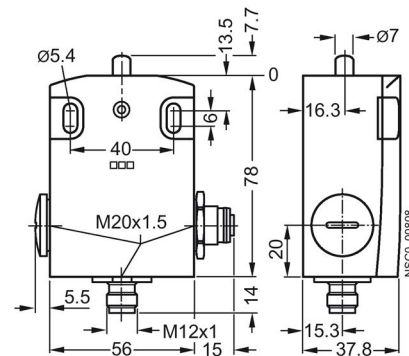

You will find further information under:

Actuators and their actuation (Page 71)

Mechanical safety switches with separate actuation (Page 147)

4.9.8 Safety switches for AS-Interface with separate actuation

4.9.8.1 Overview

The 3SF1 safety switches with safety-related communication are directly connected via the AS-Interface bus system. As a result, the safety functions are no longer conventionally wired. The ASIsafe electronics are integrated within the switch enclosure in 3SF1 safety switches.



Figure 4-14 3SF1 safety switches for AS-Interface with separate actuator

The 3SF1 safety switches with separate actuator have the same enclosure as the mechanical position switches.

4.9.8.2 Actuators

The actuator head is included in the scope of delivery. It can be offset by $4 \times 90^\circ$ to allow actuation from four directions. The switches can also be approached from above.

The actuator is not included in the scope of delivery of the position switch and must be ordered separately. There are six variants to choose from, depending on the application.



The actuator is coded. This prevents simple tampering by hand or with tools.

For additional security, a stainless steel lock insert that accommodates up to eight padlocks is offered (see Actuator accessories (Page 137)).

For use in dusty environments, a dust cap is offered for safety switch 3SF1...-..V10 that protects the actuator entries of the actuator head from dirt (see Actuator accessories (Page 137)).

4.9.8.3 LED display

The switches have a display with three LEDs:

| Status display (operating status) | | | |
|-----------------------------------|--|--|---|
| LED | LED 1 (F-IN1) | LED 2 (F-IN2) | LED 3 AS-i/Fault |
| |  yellow |  yellow |  green/red |

4.9.8.4 Connection with separate actuation

The connection to the AS-Interface is made via a 4-pin M12 plug connector (plastic version) to the yellow AS-Interface bus cable.

The 50 mm and 56 mm-wide enclosures also have an M12 socket for connecting a second position switch. As a result, category 4 according to ISO 13849-1 (EN 954-1) or SIL2/SIL3 according to IEC 61508 is achieved.

4.9.8.5 Technical data for safety switches for AS-Interface with separate actuation with tumbler

Technical data in Siemens Industry Online Support

Technical data sheet

You can also find the technical data of the product at Siemens Industry Online Support (<https://support.industry.siemens.com/cs/ww/en/ps/>).

1. Enter the full article number of the desired device in the "Product" field, and confirm with the Enter key.
2. Click the "Technical data link.

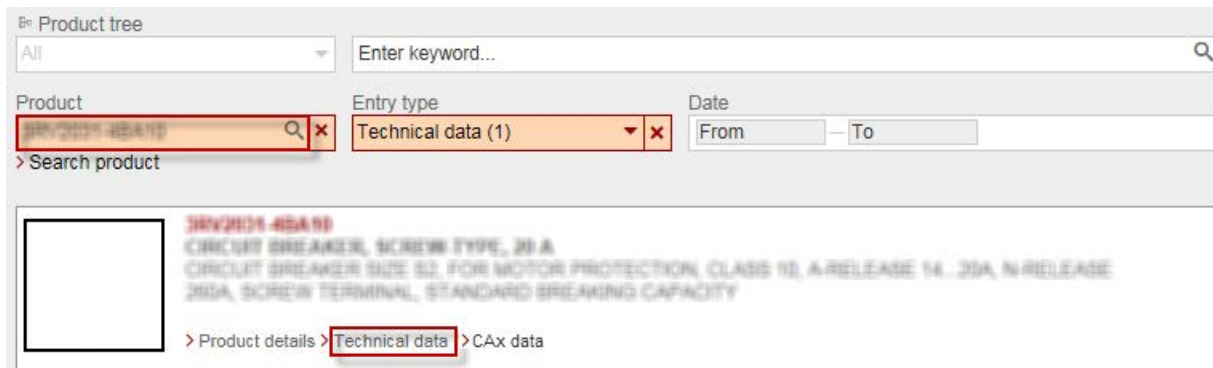

Product tree

All

Product: Entry type: Date: -

> Search product

3RV2015-4BA10
 CIRCUIT BREAKER, SCREW TYPE, 20 A
 CIRCUIT BREAKER SIZE S2 FOR MOTOR PROTECTION, CLASS 10, A-RELEASE 14, 20A, N-RELEASE 20A, SCREW TERMINAL, STANDARD BREAKING CAPACITY

> Product details > **Technical data** > CAx data

4.9 3SF1 mechanical safety switches for AS-Interface

4.9.8.6 Dimension drawings for safety switches for AS-Interface with separate actuation

Enclosure width 31 mm, EN 50047
3SF1234-..V..

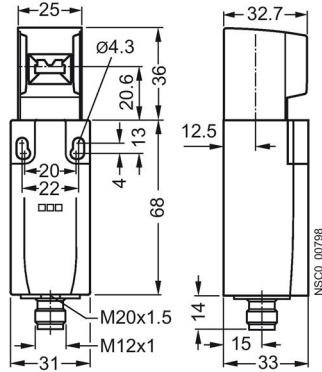

Enclosure width 50 mm
3SF1244-..V..

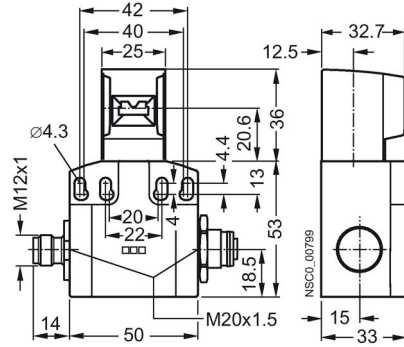

Enclosure width 40 mm, EN 50041
3SF1114-..V..

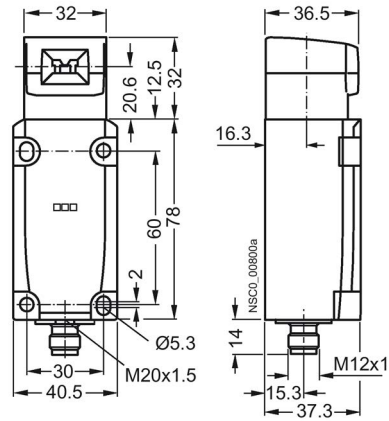

Enclosure width 56 mm
3SF1124-..V..

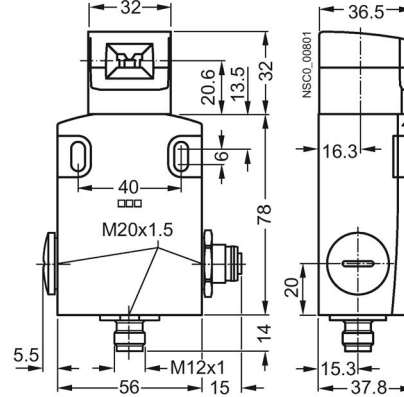

4.9.9 Pin assignment

Plug connector M12, 4-pin



- 1 ASi+
- 2 Not used
- 3 ASi-
- 4 Not used

Socket M12, 4-pin

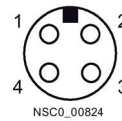

- 1 Channel 2
- 2 Not used
- 3 Channel 2
- 4 Not used

4.9.10 Safety switches for AS-Interface with separate actuation with tumbler

4.9.10.1 Overview

The mechanical safety switches for AS-Interface with tumbler are special safety-related devices that prevent accidental or intentional opening of protective doors, protective grilles, or other covers as long as dangerous conditions exist, e.g., follow-on motions of shut-down machines.

The 3SF1 safety switches with safety-related communication can be directly connected via the AS-Interface bus system. As a result, the safety functions no longer have to be conventionally wired.

The ASIsafe electronics are integrated within the switch enclosure in 3SF1 safety switches.



Figure 4-15 3SF13 safety switches with tumbler and with integrated ASIsafe electronics

4.9.10.2 Actuation

Actuators

The actuator head is included in the scope of delivery. It can be offset by $4 \times 90^\circ$ to allow actuation from four directions. The switches can also be approached from above.

The actuator is not included in the scope of delivery of the position switch and must be ordered separately. There are six variants to choose from, depending on the application.

The actuator is coded. This prevents simple tampering by hand or with tools.

For additional security, a stainless steel lock insert that accommodates up to eight padlocks is offered.

For use in dusty environments, a rubber cap is offered that protects the actuator entries of the actuator head from dirt.

4.9.10.3 3SF13..-....-1BA1

The protective door is closed when the machine is running. The actuator is located in the safety switch and is interlocked there. The positive-opening contacts of the safety switch are closed in this state. An 8 x 4 bit code table is transferred via the closed contacts (channel 1 - actuator monitoring; channel 2 - magnet monitoring) and is passed from the AS-Interface module to the AS-i bus cable. The safety monitor connected to the AS-i bus cable evaluates the transferred code table. For maintenance purposes, there is a need to manually intervene behind the protective grille. The operator switches off the machine for this purpose. The user must ensure that the protective grille can only be opened after the machine has come to a standstill. It is not possible to restart the machine until the protective door is closed and the actuator is interlocked. The contacts used for monitoring the protective door are connected with positive locking by the actuator such that the position of the protective door is detected immediately. The contacts used for monitoring the blocking means are connected with positive locking to the blocking element such that a failure of the tumbler device is detected by the safety monitor. An integrated protection against incorrect closing prevents the blocking element from being in the blocking position even though the actuator is still outside the safety switch.

With the monitoring of channel 1 (actuator) and channel 2 (magnet) of position switches 3SF13..-....-1BA1, PL d according to ISO 13849-1 and SIL2 according to IEC 61508 are achieved for the corresponding operation. The PFH_D value of the entire loop according to IEC 61508 must be calculated by the user. The PFH_D value of the position switch can be calculated from failure rate λ_D . Calculation of the failure rate is described in Chapter Failure rates (Page 19).

- Channel 1: 1-channel actuator monitoring
- Channel 2: 1-channel tumbler safety function

SIL 1/PL c with setting in the AS-Interface Monitor:

2-channel conditionally dependent:

- Feedback from magnet available
- Reclosing condition: Door must not be opened

SIL 2/PL d with setting in the AS-Interface Monitor:

2-channel dependent:

- Feedback from magnet available
- Reclosing condition: Door must be opened

4.9.10.4 3SF13...-1BA4

The protective door is closed when the machine is running. The actuator is located in the safety switch and is interlocked there. The positive-opening contacts of the position switch are closed in this state. An 8 x 4 bit code table is transferred via the closed contacts (channel 1: 2-channel actuator monitoring; channel 2: 1-channel magnet monitoring) and is passed from the AS-Interface module to the AS-i bus cable. The "Safety at Work" evaluation unit, such as an ASIsafe 3RK1 safety monitor, which is connected to the AS-i bus cable, evaluates the transferred code table. For maintenance purposes, there is a need to manually intervene behind the protective door. The operator switches off the machine for this purpose. The user must ensure that the protective door can only be opened after the machine has come to a standstill. It is not possible to restart the machine until the protective door is closed and the actuator is interlocked. The contacts used for monitoring the protective door are connected with positive locking by the actuator such that the position of the protective door is detected immediately. The contacts used for monitoring the blocking means are connected with positive locking to the blocking element such that a failure of the tumbler device is detected, e.g., by an ASIsafe 3RK1 safety monitor. An integrated protection against incorrect closing prevents the blocking element from being in the blocking position even though the actuator is still outside the safety switch.

With the channel monitoring (channel 1: 2-channel actuator monitoring; channel 2: 1-channel magnet monitoring) of position switches 3SF13...-1BA4, PL d according to ISO 13849-1 and SIL2 according to IEC 61508 are achieved for the corresponding operation. The PFH_D value of the entire loop according to IEC 61508 must be calculated by the user. The PFH_D value of the position switch can be calculated from failure rate λ_D . Calculation of the failure rate is described in Chapter Failure rates (Page 19).

- Channel 1: 2-channel actuator monitoring
- Channel 2: 1-channel tumbler safety function

Category 2/SIL 2/PL d when set in the AS-Interface Monitor:

2-channel conditionally dependent:

- Feedback from magnet available
- Reclosing condition: Door must not be opened

Note

Note on 3SF13..-1B.4

Due to combination of two-channel querying of the actuator (position monitoring of the guard) with one-channel querying of monitoring of the blocking means, in the event of corresponding operation safety category 3 and performance level d in compliance with EN ISO 13849-1 or SIL 2/IEC 61508 are also achieved in the "conditionally dependent" mode of operation for the "interlock" safety function.

The PFD value of the entire loop must be calculated by the user.

The PFD value of the tumbler is listed in the technical data.

4.9.10.5 Direct connection of safety monitor, Category 3/SIL 2/PL d

- Spring-locked position switch with tumbler
- Direct connection to AS-Interface
- Unsafe release
- The position switch transfers the information of the two actuator contacts on a transfer channel because the discrepancy of the actuator contacts is already evaluated in the switch. The second transfer channel is therefore available for the magnet monitoring (for the standard process evaluation).

Configuring

Protective door monitoring with ASIMON monitoring block, type "conditionally dependent":

Category 3 according to EN 954-1 or SIL2 according to IEC 62061 or PL d according to ISO 13849-1

The safety monitor monitors the actuator and the magnet ("conditionally dependent" monitoring). When you activate the "Independent In -1" parameter, you can release the protective door without having to open it afterwards.

The standard output integrated in the position switch is used to release the protective door.

4.9.10.6 Interlock types

There are two versions for interlocking the actuator:

- **Spring-locked** (closed-circuit principle): Actuator inserted and mechanically interlocked. Actuator is released by applying voltage to the magnet or, in the case of voltage drop, by means of a manual or key-operated auxiliary release mechanism (version-dependent).
Release variants:
 - Auxiliary release
 - Key-operated release
 - Emergency release
 - Escape release
- **Solenoid-locked** (open-circuit principle): Actuator released. Actuator is interlocked by applying voltage to the magnet. Actuator is released by switching off the voltage applied to the magnet.

Note

Risk analysis

Tumblers based on the open-circuit principle may only be used if the application's risk analysis shows that use of closed-circuit current variants is not possible. An identical safety level must be established by suitable measures.

4.9.10.7 LED display

Meaning of switch positions and LED indications

The switches have a display with four LEDs:

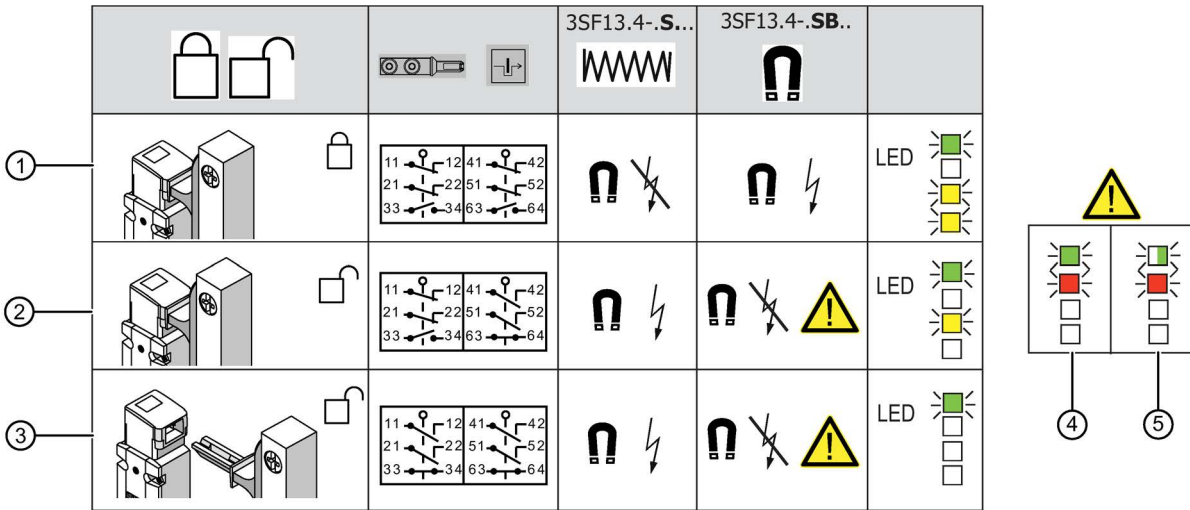













| | | Switch position | Switch with spring lock (closed-circuit principle) | Switch with solenoid lock (open-circuit principle) | LED display |
|---|--|--|--|--|--|
| ① | The actuator is inserted. The protective device is interlocked. | 11/12, 21/22, 41/42, 51/52 closed; 33/34, 63/64 open | Magnet not energized. | Magnet energized. | LED 1 = lit green LED 2 = off LED 3 = lit yellow LED 4 = lit yellow |
| ② | The actuator is inserted. The protective device is not interlocked. | 11/12, 21/22, 63/64 closed; 41/42, 51/52, 33/34 open | Magnet energized. | Magnet not energized. | LED 1 = lit green LED 2 = off LED 3 = lit yellow LED 4 = off |
| ③ | The actuator is withdrawn. The protective device is not interlocked. | 33/34, 63/64 closed; 11/12, 21/22, 41/42, 51/52 open | Magnet energized. | Magnet not energized. | LED 1 = lit green LED 2 = off LED 3 = off LED 4 = off |

| | Error case | LED display |
|---|---|---|
| ④ | Communication has failed. | LED 1 = lit green LED 2 = lit red LED 3 = off LED 4 = off |
| ⑤ | Device not addressed. Slave address 0. | LED 1 = green flashing LED 2 = lit red LED 3 = off LED 4 = off |

 **WARNING**

Releasing the solenoid-locked switch

The tumbler of the solenoid-locked switches is released by deactivating the current. Do not use these switches if there is a hazard due to releasing in the event of voltage failure. Carry out a risk analysis with regard to the safety level.

| Status display (operating state) | LED combinations | | | |
|-------------------------------------|--|--|--|---|
| LED 1 (AS-I) |  green Communication OK |  flashes green |  green |  green Communication OK |
| LED 2 (FAULT) | Off |  red Slave has the address "0" |  red Communication failure | Off |
| LED 3 (F-IN1) |  yellow Actuator inserted |  yellow Actuator inserted |  yellow Actuator inserted | Off Actuator not inserted |
| LED 4 (F-IN2) |  yellow Actuator interlocked |  yellow Actuator interlocked |  yellow Actuator interlocked | Off Actuator not locked |

4.9.10.8 Connection with tumbler

The connection to the AS-Interface is made using a 4-pin M12 plug connector (plastic version) to the yellow AS-Interface bus cable (the low current consumption of the magnet, i.e., max. 170 mA, means that an additional auxiliary power feed is not necessary).

4.9.10.9 Technical data for safety switches for AS-Interface with tumbler

Technical data in Siemens Industry Online Support

Technical data sheet

You can also find the technical data of the product at Siemens Industry Online Support (<https://support.industry.siemens.com/cs/ww/en/ps/>).

1. Enter the full article number of the desired device in the "Product" field, and confirm with the Enter key.
2. Click the "Technical data link."

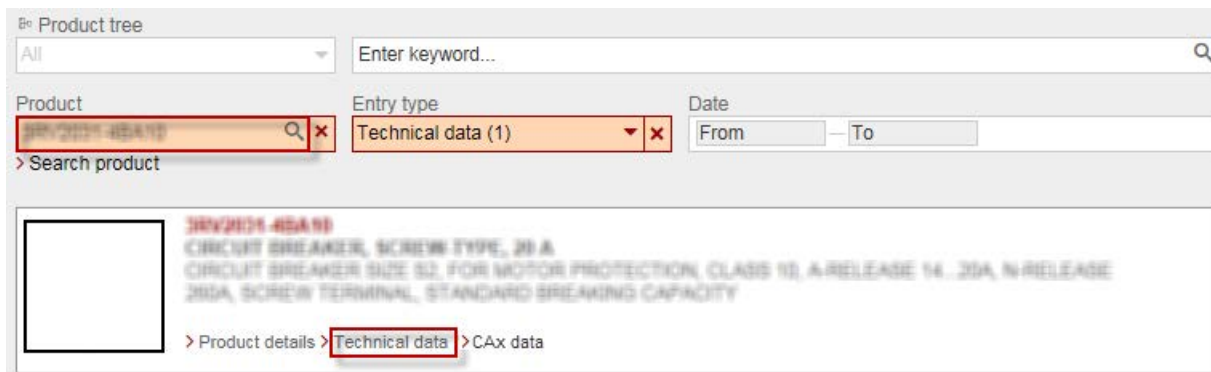

Note

Position switch with high degree of protection IP69

Position switches with article number 3SF1324-1S.21-1BK4 fulfil degree of protection IP69.

4.9.10.10 Maximum achievable safety category

| Function | Safety category |
|-----------|-----------------|
| Interlock | max. PLe/Cat. 3 |
| Tumbler | max. PLd/Cat. 2 |

4.9.10.11 Dimension drawings for safety switches for AS-Interface with tumbler

| | |
|--|---|
| <p>Spring-locked, with auxiliary release, front 3SF1324-.SD1., 3SF1324-.SG1., 3SF1324-.SJ1., 3SF1314-.SD1., 3SF1314-.SG1., 3SF1314-.SJ1.</p> | <p>Spring-locked, with auxiliary release with lock 3SF1324-.SE1., 3SF1314-.SE1.</p> |
| | |
| <p>Spring-locked, with escape release 3SF1324-.SF1., 3SF1314-.SF1.</p> | <p>Solenoid-locked 3SF1324-.SB1., 3SF1314-.SB1</p> |
| | |

You can find further information at: Combinations (Page 136)

4.10 Safety relays

4.10 Safety relays



4.10.1 Overview of safety relays

Note

It is possible to use different types of safety relays.

You can use SIRIUS 3SK safety relays to evaluate sensors. For further information, refer to the SIRIUS 3SK1 safety relays manual

(<https://support.industry.siemens.com/cs/ww/de/view/67585885>).

| Monitoring units | Number of encoders | Enabling/signaling circuits | Article No. | |
|--|---|-----------------------------|---------------|---------------|
|  3SK1111-1AB30 | 3SK1 safety relays, Standard or Advanced basic units | | | |
| | with 24 V DC relay output | 1 | 3 NO/1 NC | 3SK1111-1AB30 |
| | | 6 ¹⁾ | 3 NO/1 NC | 3SK1121-1AB40 |
| | with 24 V DC semiconductor output | 1 | 2x F-DQ/1 QM | 3SK1112-1BB40 |
|  3SK2112-1AA10 | 3SK2 safety relays, basic units | | | |
| | with 24 V DC semiconductor output | 4 | 2x F-DQ/1 QM | 3SK2112-1AA10 |
| | | 8 | 4 x F-DQ/2 QM | 3SK2122-1AA10 |
|  3SE6806-2CD00 | 3SE68 safety relay | | | |
| | with 24 V DC relay output | 6 | 2 NO/1 NC | 3SE6806-2CD00 |
| 1) Only when up to 5 3SK1220 expansion units are used | | | | |

4.10.2 3SE6806-2CD00 safety relay

Up to six protective devices (sensors) can be connected to the 3SE6806-2CD00 safety relay.

The device has six p-switching semiconductor outputs (Y1 ... Y6), which signal the status of the connected protective devices.

The 3SE6806-2CD00 safety relay has two floating enabling circuits (safe circuits) as normally open contact circuits and one floating signaling circuit as a normally closed contact circuit. The number of enabling circuits can be increased by adding one or more 3TK2830 expansion modules.

Note

Please observe the relevant standards and regulations.

The user must evaluate and dimension the safety chain according to the applicable standards and regulations for the particular level of safety required.

Note

Several safety components in series.

If several safety components are connected in series, in certain circumstances the performance level in accordance with EN ISO 13849-1 is diminished because of reduced error detection.

4.10 Safety relays

4.10.3 Achievable safety level in combination with safety relays

Position and door monitoring with SIRIUS 3SE5 mechanical safety switches including positive opening

The following table lists the maximum achievable safety level of a safety relay in combination with a position switch:

| | | Compact switches 3SE54 | Standard position switches 3SE51/52 | Hinge switches 3SE51/52 | Safety switches with separate actuator 3SE51/52 | Safety switches with optional tumbler function 3SE53 |
|--------------------------------|---|------------------------|-------------------------------------|-------------------------|---|--|
| Number of position switches | | 1 | 1 | 1 | 1 | 1 |
| + | safety relay (e.g. 3SK) with | | | | | |
| = Max. achievable safety level | Monitoring 1 x NC contact | SIL 1/PL c | | | | |
| | Monitoring 2 x NC contacts or 1 x NC contact 1 x NO contact | SIL 1/PL c | | SIL 2/PL d | | |

The following table lists the maximum achievable safety level of a safety relay in combination with two position switches:

| | | | Compact switches 3SE54 | Standard position switches 3SE51/52 | Hinge switches 3SE51/52 | Safety switches with separate actuator 3SE51/52 | 3SE53 safety switches with optional tumbler function |
|--------------------------------|--|---|------------------------|-------------------------------------|-------------------------|---|--|
| Number of position switches | | | 2 | 2 | 2 | 2 | 2 |
| | Safety relay (e.g. 3SK) + | | | | | | |
| = Max. achievable safety level | 3SE51/52 standard position switches | + | SIL 3/PL e | | | | |
| | 3SE51/52 safety switches hinge switches | + | | | | | |
| | 3SE51/52 safety switches with separate actuator | + | | | | | |
| | 3SE53 safety switches with optional tumbler function | + | | | | | |

Safe protective door tumbler with safety switches and separate 3SE5 actuator with positive opening

The following table lists the maximum achievable safety level of a safety relay in combination with one or two position switches:

| | Safety switches with tumbler | |
|-----------------------------------|------------------------------|-------------------|
| Number of safety switches + | 1 | 2 |
| safety relay (e.g. 3SK2) + | | |
| = Max. achievable safety level | SIL 2/PL d | SIL 3/PL e |

Position monitoring with 3SE6 magnetically operated switches

The following table lists the maximum achievable safety level of a safety relay in combination with a magnetically operated switch:

| | 3SE66/3SE67 magnetically operated switches | |
|--------------------------------|--|------|
| Magnetically operated switch + | 1 NO + 1 NC | 2 NC |
| safety relay (e.g. 3SK) | | |
| = Max. achievable safety level | SIL 3/PL e | |

4.10 Safety relays

4.10.4 Terminal assignments

The 3SE6806-2CD00 safety relay can be used in safety circuits in accordance with EN 60 204-1, e.g. for moving covers and protective doors. The device is suitable for the evaluation of 3SE6 magnetic monitoring systems, but only with a configuration of 1 NO contact and 1 NC contact. Depending on the external circuitry, the safety relay can achieve up to SIL 2 in accordance with DIN EN 61 508. The 3SE6806-2CD00 safety relay has two floating enabling circuits (safe circuits) as NO circuits, and one floating signaling circuit as an NC circuit. The number of enabling circuits can be increased by adding one or more 3TK2830 expansion blocks.

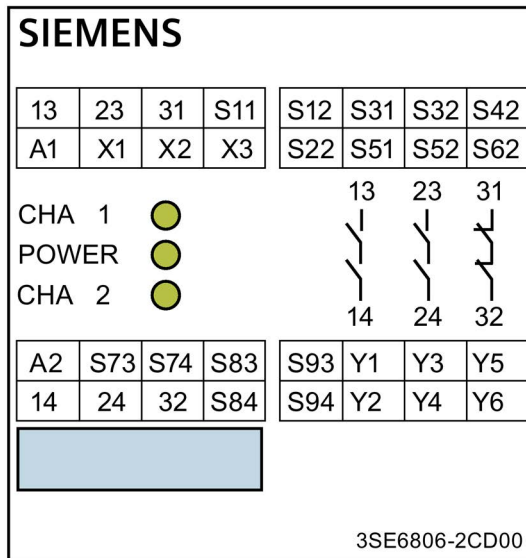

Figure 4-16 Front of the 3SE6806-2CD00 safety relay

| Terminal assignments | |
|----------------------|--|
| A1 | L/+ |
| A2 | L/- |
| S11, S12 | Channel 1, NC contact |
| S11, S22 | Channel 2, NC contact |
| S31, S32 | Channel 3, NC contact |
| S31, S42 | Channel 4, NC contact |
| S51, S52 | Channel 5, NC contact |
| S73, S74 | Channels 1 + 2, NO contacts (parallel) |
| S83, S84 | Channels 3 + 4, NO contacts (parallel) |
| S93, S94 | Channels 5 + 6, NO contacts (parallel) |
| X1, X2, X3 | ON button, feedback circuit |
| 13, 14 | Enabling circuit 1 (safe NO contact) |
| 23, 24 | Enabling circuit 2 (safe NO contact) |
| 31, 32 | Floating signaling circuit |
| Y1 to Y6 | Status message, channels 1 to 6 |

4.10.5 LED display, 3SE6806 safety relay

Refer to the following table for the meanings of the LED displays on the front of the safety relay:

| | | | | |
|---|--|--|--|--|
| CHA 1 | | | | |
| POWER | | | | |
| CHA 2 | | | | |
| S11/S12/S22 S31/S32/S42 S51/S52/S62 | | | | |
| S73/S74 S83/S84 S93/S94 | | | | |
| 13 - 14 23 - 24 | | | | |
| 31 - 32 | | | | |

4.10.6 Technical data for 3SE6806 safety relay

4.10.6.1 Technical data in Siemens Industry Online Support

Technical data sheet

You can also find the technical data of the product at Siemens Industry Online Support (<https://support.industry.siemens.com/cs/ww/en/ps/>).

1. Enter the full article number of the desired device in the "Product" field, and confirm with the Enter key.
2. Click the "Technical data link.

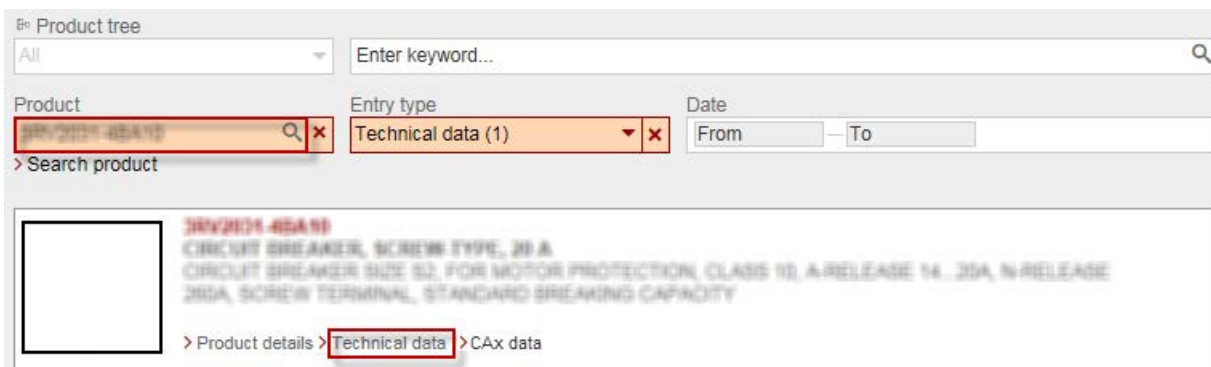

4.10.7 Typical circuit diagram with safety relay function

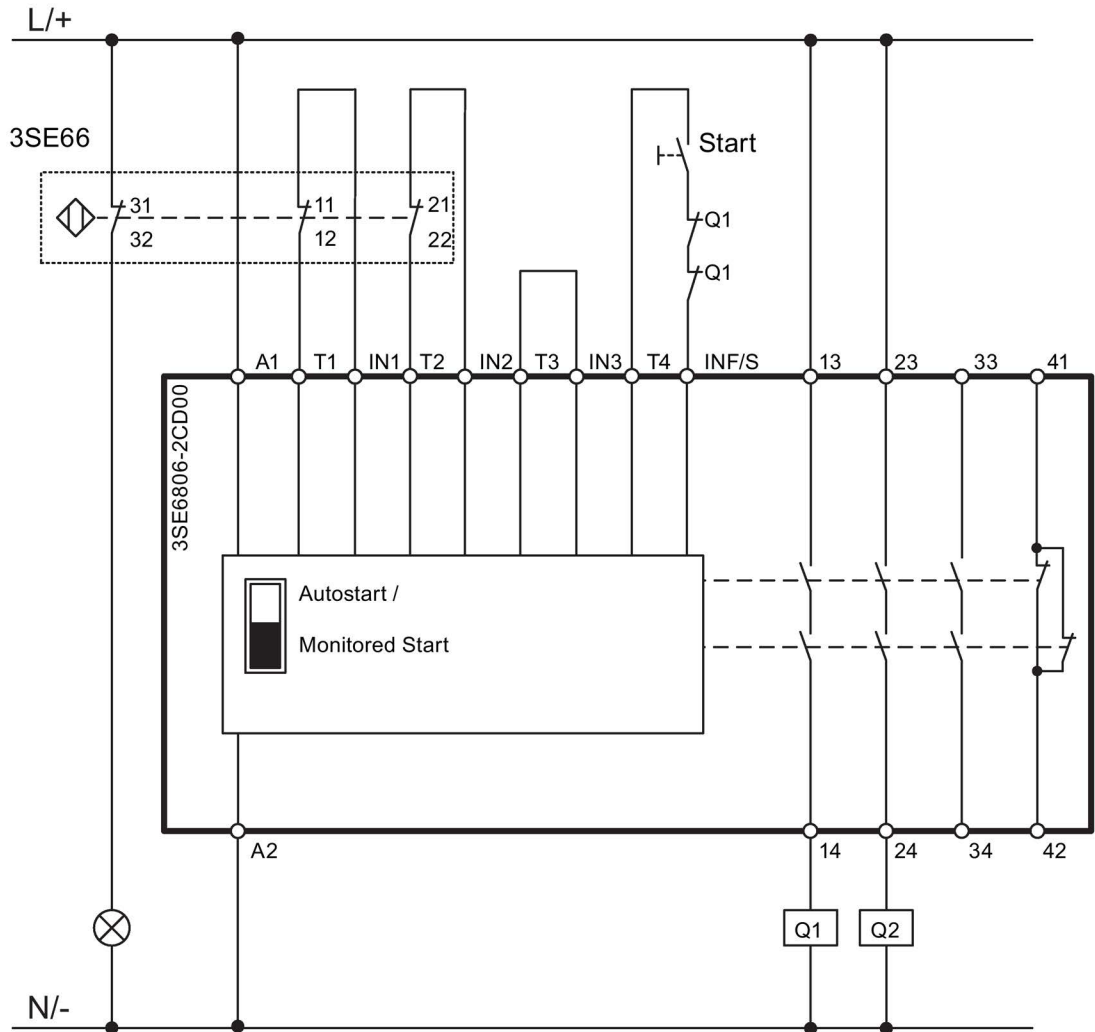

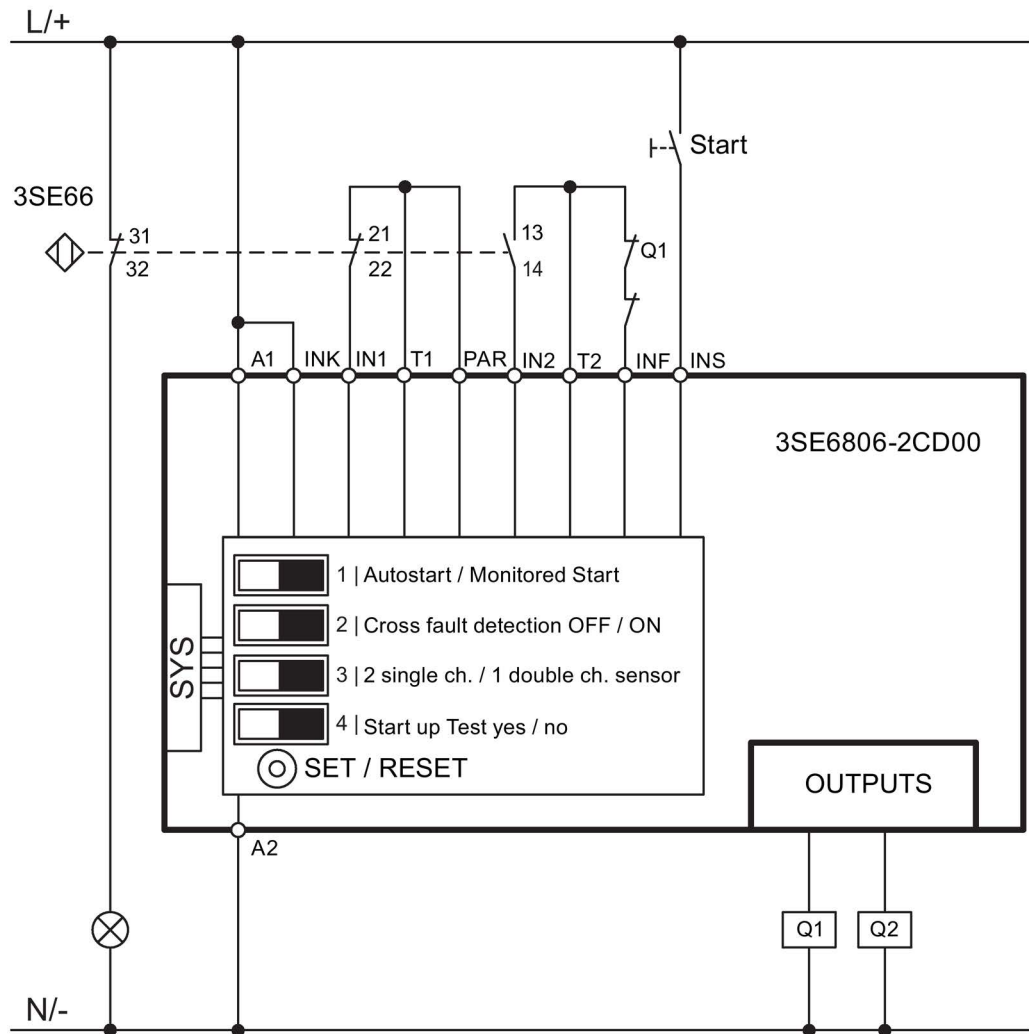

4.10 Safety relays

Application examples

5.1 Installation instructions

| |
|--|
| NOTICE |
| <p>Risk of property damage. Failure to observe this caution may result in damage to the switch.</p> <ul style="list-style-type: none"> • Make sure that the actuating element of any actuator with a roller can approach in such a way that no lateral forces occur. The actuating element should be moved on the roller in a flat manner. • The actuating element must be configured according to its purpose so that the position switch is not subjected to unnecessary stress on actuation. |

5.1.1 Protection against approach and overtravel

| |
|--|
| NOTICE |
| <p>Risk of property damage. Do not use position switches as a mechanical endstop.</p> <p>Place the position switches in such a position that they are not damaged during approach and overtravel. For this reason, it is not permissible to use them as a mechanical stop. Choose a height for the control rod or cam that is less than the total travel in the switch, so that no mechanical loading of the switch or its mounting occurs.</p> |

Installation instructions for rounded and roller plungers

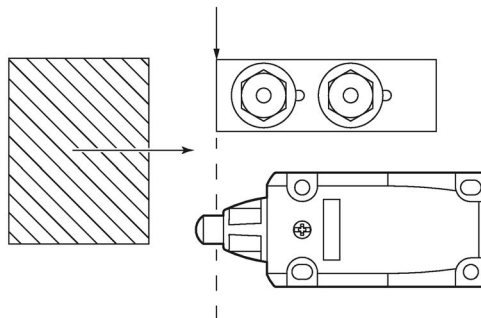

5.1 Installation instructions

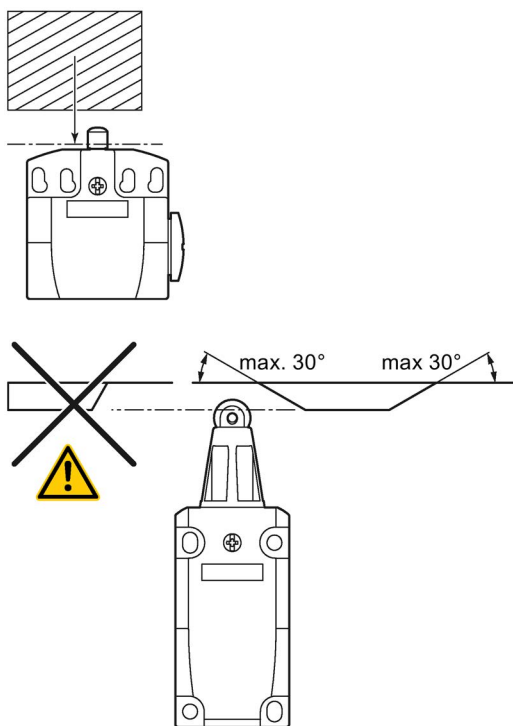

Installation instructions for position switches with roller lever, angular roller lever, twist lever, and rod lever

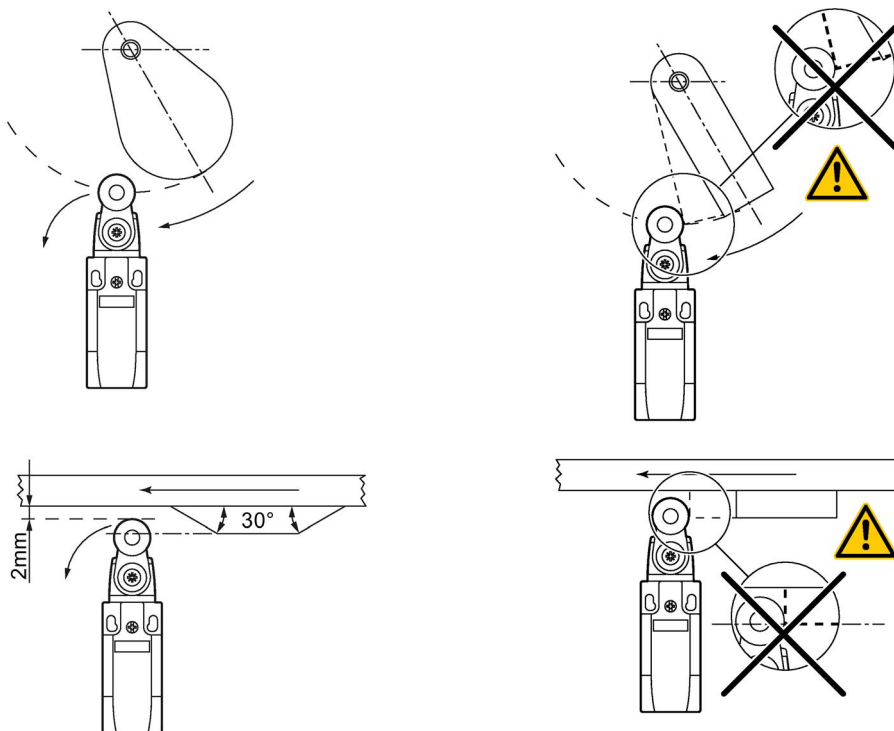

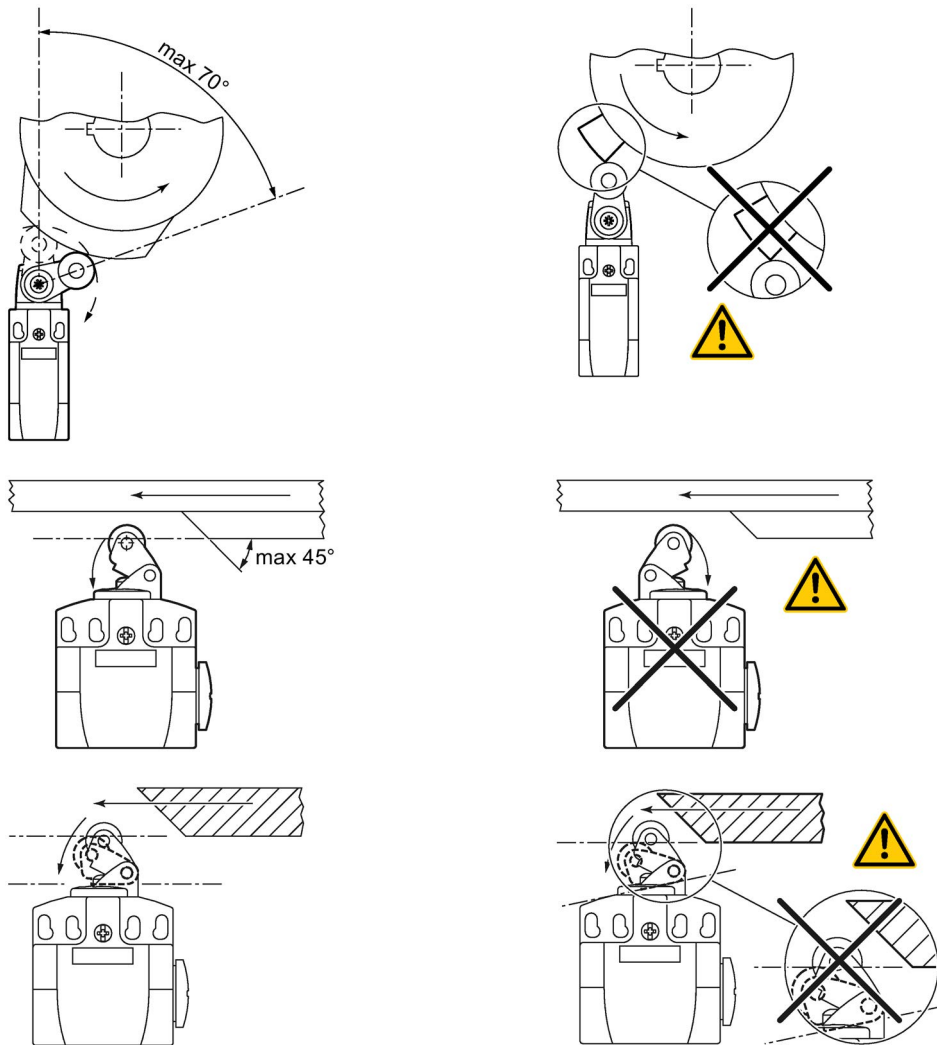

Position switches with cable

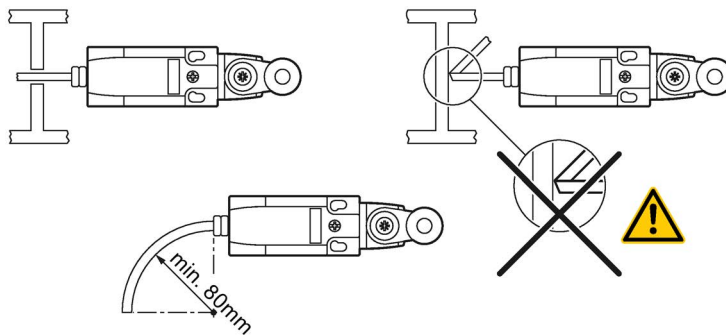

When moisture is present

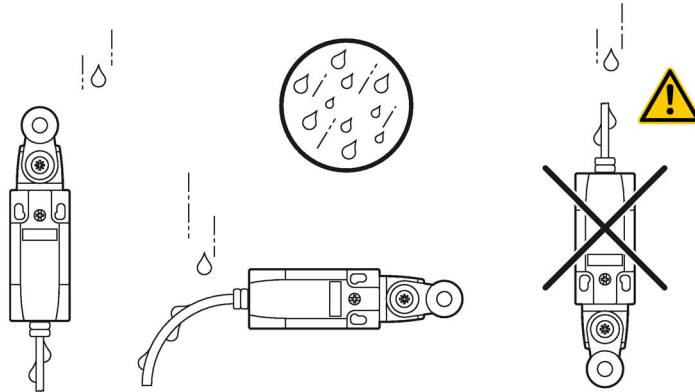

5.1.2 Cable entry

Seal the cable entries (M20 x 1.5) carefully in order to avoid a reduction in the degree of protection according to DIN VDE 0470 and IEC 60529. If a cable entry is not needed, fit it with a threaded dummy cap. The protective ground connection is located in the metal enclosure.

Note

Proper use of cable entries.

Only cable entries that meet the requirements described in DIN EN 61241-0 are permitted to be used. The cable entries must be designed and mounted in such a way that the degree of protection according to DIN VDE 0470 and IEC 60529 is not impaired. Unused cable entries must be sealed with the supplied threaded caps. Required torque: 1.1 Nm.

NOTICE

Risk of property damage.

In case of damage or wear, the complete switch must be replaced. The replacement of individual parts or modules is not permitted.

NOTICE

Risk of property damage.

Avoid bending the connecting cable. If bending of the connecting cable cannot be avoided, the bending radius should not be less than 80 mm.

DIN EN 60204-1 stipulates:

Position switches must be positioned in such a way that they are not damaged in the case of overtravel. They must be positioned in such a way that they are protected against inadvertent actuation.

Instructions based on practical experience

Position switches, especially open-type position switches, must be mounted on a flat base in order not to exert any bending moment on the plastic enclosure when screwing into place.

| |
|---|
| NOTICE |
| Risk of property damage. The installation location of position switches and their electrical connecting cables must be at least 400 mm above the floor or the platform where maintenance and repair personnel work. |

Make sure that the following actions can be performed easily and safely:

- Fastening
- Connecting
- Setting up
- Testing during the operating sequence

Note the following installation instructions:

- Position switches should be accessible without having to dismantle mechanical parts (except for protective grilles, maintenance doors).
- Make sure there is sufficient room for setting up and connecting.
- Seal the cable entry in such a way that liquids (splash water, drill emulsion, etc.) cannot penetrate the enclosure interior.
- Mount the position switch in such a way that chips, coarse dirt, oils, and coolants do not impair the function.
- Make sure that position switches can be easily tested during the operating sequence.
- Use a suitable cover or appropriate positioning to prevent chips from damaging or blocking the position switch.
- Take steps to prevent an inadvertent actuation by operating personnel.
- Ensure sufficient covers as a protection against inadvertent actuation as a result of normal movements of operating personnel.
- Take steps to rule out the possibility of mechanical damage during transport of the position switch.
- Avoid bending the connecting cable. If bending of the connecting cable cannot be avoided, the bending radius should not be less than 80 mm.

Ensure the following:

- Positive locking on a significant portion of the actuator travel of the position switch up until positive opening ⊕.
- Configuration of the switch as a switch with positive-opening operation and fail-safe signal processing.
- Adjustment of the actuating travel to conform to the positive opening operation travel according to manufacturer specifications.
- Actuation of the total positive-opening operation travel before intervention in the danger zone is possible.
- Positively-locking mounting (position can be rotated and offset) of the switch and final controlling element (cam disk, control rod), use of oblong hole mounting only with additional fixing means.
- Securing of the mounting elements of the switch and final controlling element (cam disk, control rod) against self-loosening.
- Sufficient mechanical strength of the support elements and functional elements for the switch.
- Protection against overtravel.
- Protection against external damage.
- Adaptation of the cable entry to the required degree of protection of the switch.
- Accessibility for maintenance and functional testing.
- Assurance that easy bypassing of the protective function is not possible.

 **CAUTION**

Risk of property damage.

Do not use the position switch as an endstop, as this may cause damage to the switch.

5.1.3 Securing against change of position (fixing)

To secure position switches with a safety function against a change of position, **keyed** techniques must be employed upon installation between the enclosure and mounting surface, such as the following:

- Mounting using round holes
- Use of additional dowel pins or stops when mounting using oblong holes

5.1.4 Quick-release device for enclosure width 40 mm

1. Mount the intermediate plate (b) on the position switch (a).
2. Install the base plate (c) at the installation location.
3. Fit the position switch and use the locking lever (d) to interlock it.

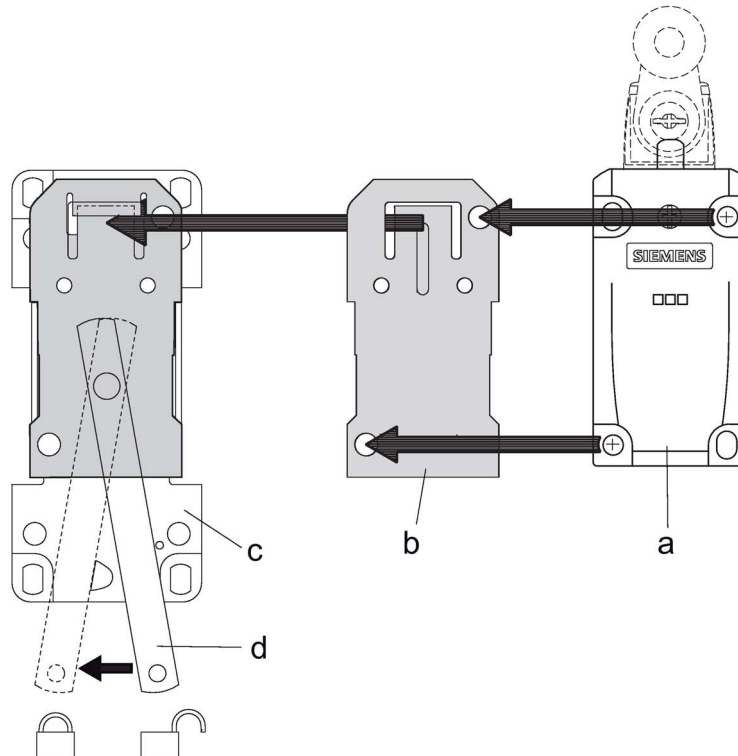

Figure 5-1 Quick-release device

5.2 Application suggestion

System description/application suggestion

The protective door is closed when the machine is running. The actuator is located in the safety switch and is interlocked there. In this case, the enable path of the evaluation unit is closed and the enable path of the contactor control unit is open. For maintenance purposes, there is a need to manually intervene behind the protective grille. The operator switches off the machine for this purpose.

This opens the enable path of the evaluation unit and shuts down the performance level of the machine. Because dangerous machine movement does not cease immediately, the safety switch must not enable the actuator until the follow-on movement of the machine ends. This is ensured by a suitable contactor control unit, such as a standstill monitor or a delay module.

When the protective door is open, the safety contacts (positive-opening normally closed contact \ominus) prevent the machine from restarting. The additional normally open contacts can be used as signaling contacts. These functions are not used for safety purposes but rather for machine availability.

With suitable evaluation units, the normally open contacts can also be incorporated in the safety circuit as an additional check.

The contacts used for monitoring are connected with positive locking by the actuator such that the position of the protective door is detected immediately.

The contacts used for monitoring the blocking means are connected with positive locking to the blocking element such that a failure of the tumbler device is detected by the safety-related control system. An integrated protection against incorrect closing prevents the blocking element from being in the blocking position even though the actuator is still outside the safety switch. Thus, the contacts used for monitoring the blocking can also be used to monitor the protective device. When integrated into suitable safety concepts, the ability to perform reciprocal monitoring of contacts enables implementation of safety-related control systems up to Category 3 with Performance Level d according to ISO 13849-1 and SIL 2 according to IEC 62061.

5.2.1 Positive opening position switches

Positive opening position switches with slow-action function, snap-action function, and slow-action function with overlap

On actuation, the positive opening normally closed contact opens and reaches its positive opening point in a defined manner. On reset (closing of protective device), the contact closes at the same point (no hysteresis) in the case of slow-action contacts. When using switches with slow-action contacts, you should observe the manufacturer's specifications with respect to operating travel diagrams and actuator travel. The installation of switches must ensure their complete mechanical actuation such that the necessary positive opening travel is achieved. Position switches with snap-action contacting can also be used in the case of very slow actuating speeds and for applications in which the contacts are to switch with almost no delay. If the snap-action contact block fails, the positive opening operation \oplus is initiated by a deflection mechanism. The hysteresis actually describes only the difference between the operating point and reset point in the case of snap-action contacts. This difference results from the different geometric positions of the snap-action mechanism during the switch and reset operations. In the case of slow-action contacts, the operating point and the reset point are generally always the same because the actuator head actuates the contact mechanism linearly. There is therefore no hysteresis.

Operating distances are largely standardized, and thus it is possible to compare competitors within the usual tolerances. We can offer short-stroke contact blocks for the types of construction according to EN 50041 and EN 50047, which enable the switching operation to take place significantly earlier.

5.3 Application example - Rounded plunger

Possible application of a mechanical position switch with rounded plunger

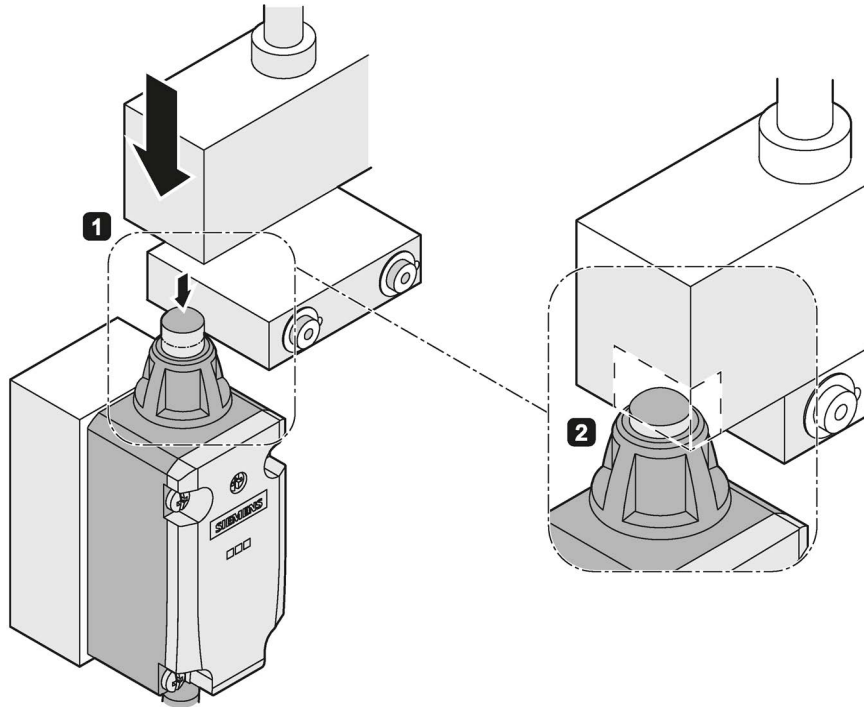

Application examples

- Door monitoring
- Endstop monitoring

Notes on installation

- Approach possible in travel direction only
- Rounded plungers and roller plungers have an overtravel and thus a longer actuator travel than other actuators.

Variants

- Rounded plunger made of plastic
- Rounded plunger made of metal

5.4 Application example - Roller plunger

Possible application of a mechanical position switch with roller plunger

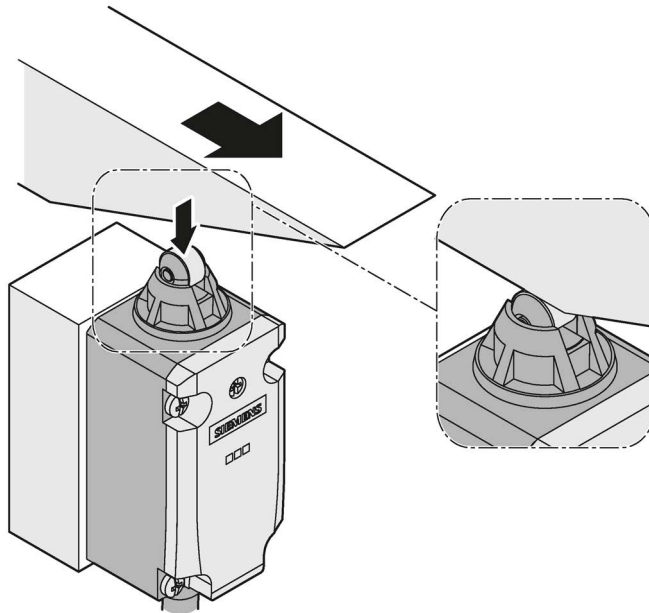

Application examples

- Conveyor belts
- Assembly lines
- Sliding doors

Notes on installation

- Approach possible in travel direction
- Approach with switching bar perpendicular to the travel axis
- Rounded plungers and roller plungers have an overtravel and thus a longer actuator travel than other actuators.
- The roller plunger is recommended in the case of lateral actuation and a relatively long overtravel distance.

Variants

Roller plunger with plastic roller

Roller plunger with stainless steel roller for frequent overtravel

5.5 Application example - Roller lever

Possible application of a mechanical position switch with roller lever

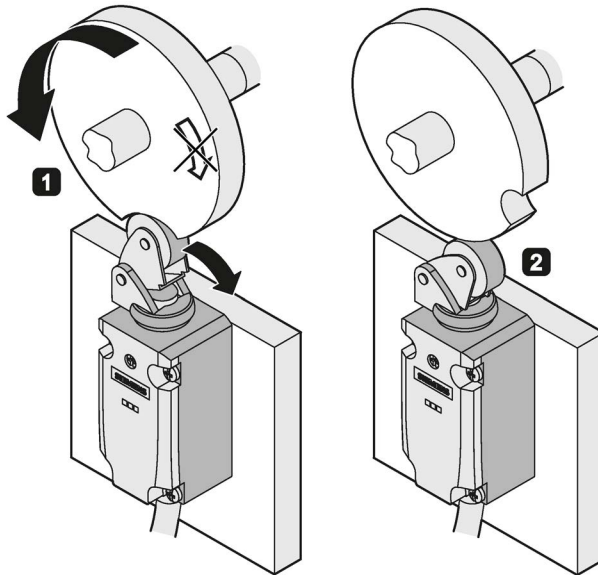

Application examples

Cam disks

Notes on installation

- Especially suitable for actuating elements made of finely-ground steel in the form of cams, bars, or cam disks without additional lubrication.
- Approach angle = trailing angle, maximum 30 °
- Each actuator can be offset by 90 °.

Variants

Roller lever (Page 75) made of metal or stainless steel with plastic roller

Roller lever made of metal or stainless steel with stainless steel roller for frequent overtravel

5.6 Application example - Angular roller lever

Possible application of a mechanical position switch with angular roller lever

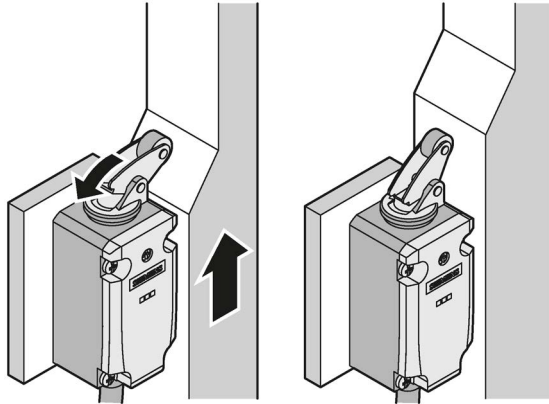

Application examples

- Installation in confined space conditions

Notes on installation

- Especially suitable for actuating elements made of finely-ground steel in the form of cams, bars, or cam disks without additional lubrication.
- High approach velocity $v_{\max} = 2.5 \text{ m/s}$
- Different approach angles ($\alpha = 30^\circ$) or trailing angles ($\gamma = 45^\circ$)

Variants

Angular roller lever made of metal or stainless steel with plastic roller

Angular roller lever made of metal or stainless steel with metal roller

NOTICE

Risk of property damage.

Do not use position switches as a mechanical endstop.

Place the position switches in such a position that they are not damaged during approach and overtravel. For this reason, it is not permissible to use them as a mechanical stop. Choose a height for the control rod or cam that is less than the total travel in the switch, so that no mechanical loading of the switch or its mounting occurs.

5.7 Application example - Spring rod

Possible application of a mechanical position switch with spring rod

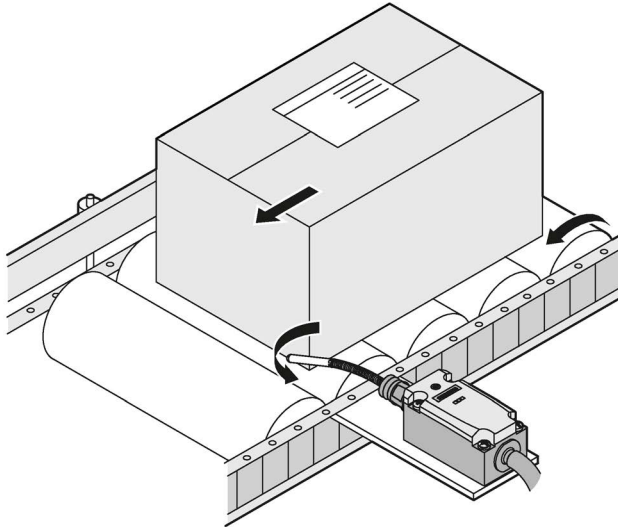

Application examples

Package conveyor systems

Notes on installation

- Approach from all directions
- With varying actuation direction
- With approach by angular objects (e.g., packages)
- With undefined actuation

Variants

Spring rod in various lengths with metal plunger

Spring rod in various lengths with plastic plunger

5.8 Application example - Twist lever

Possible application of a mechanical position switch with twist lever

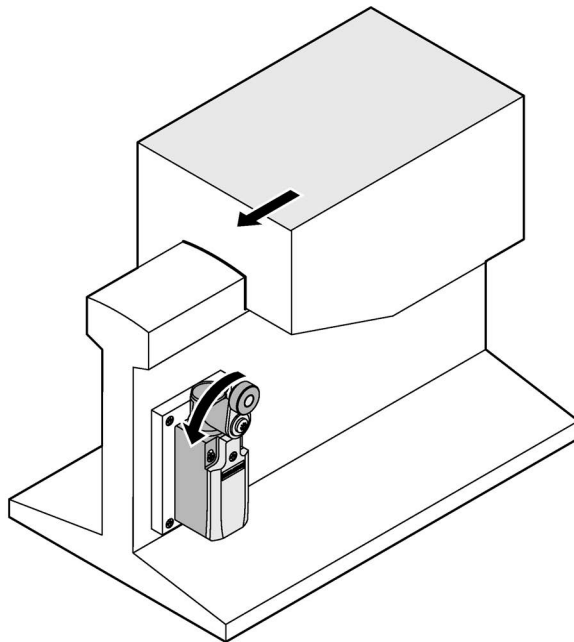

Application examples

- Conveyor belts
- Assembly lines
- Door monitoring

Notes on installation

- For high approach velocity ($v = 1.5 \text{ m/s}$)
- Many possible approaches
- Insensitive to oil, grinding dust, dirt, coarse-grained material
- In the case of twist levers, the maximum approach angle is equal to the maximum trailing angle
- 10° offset of twist levers possible
- Right, left, or right/left direction of operation can be selected in the default configuration

Variants

Twist lever with plastic roller

Twist lever with metal roller

Twist lever with ball bearing

5.9 Application example - Adjustable-height twist lever

Possible application of a mechanical position switch with adjustable-height twist lever

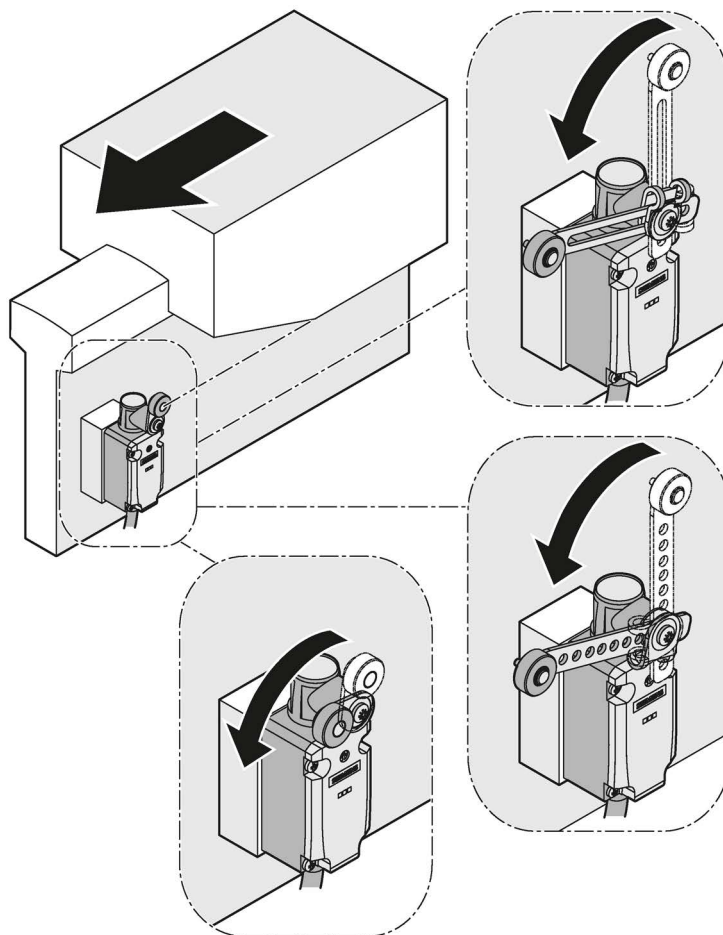

NOTICE

Risk of property damage.

To avoid property damage, do not use the last drill hole.

Application examples

- With varying approach height distances
- Conveyor belts, assembly lines
- If an actuating element with approach and trailing angles is not possible for technological reasons, e.g., bottles, packages

Notes on installation

- Many possible approaches
- Insensitive to oil, grinding dust, dirt, coarse-grained material
- In the case of twist levers, the maximum approach angle is equal to the maximum trailing angle
- 10 ° offset of twist levers possible
- Right, left, or right/left direction of operation can be selected in the default configuration

Variants

- Metal lever with pre-drilled holes with plastic roller
- Adjustable-length metal lever with
 - Plastic roller
 - Stainless steel roller
- Adjustable-length twist lever with pre-drilled holes
 - Made of stainless steel
 - Made of metal
- Adjustable-length twist lever with oblong hole
 - Made of stainless steel
 - Made of metal

5.10 Application example - Adjustable-height rod lever

Possible application of a mechanical position switch with adjustable-height rod lever

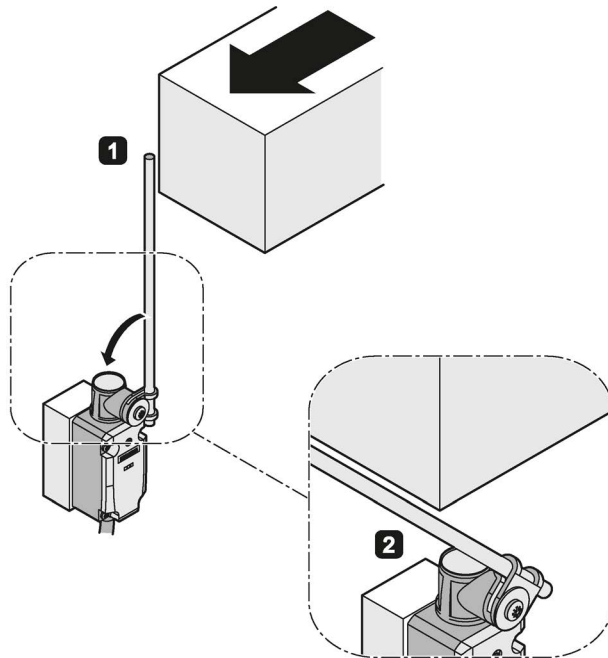

Application examples

- With approach heights of varying distances, e.g. conveyor belts, assembly lines
- When the distance between position switch and actuating element is greater for technological reasons

Notes on installation

- Many possible approaches
- Insensitive to oil, grinding dust, dirt, coarse-grained material
- If an actuating element with approach angle and trailing angle is not possible
- Infinitely adjustable

Variants

Rod lever with plastic rod

Rod lever with aluminum rod

5.11 Application example - Fork lever

Possible application of a mechanical position switch with fork lever

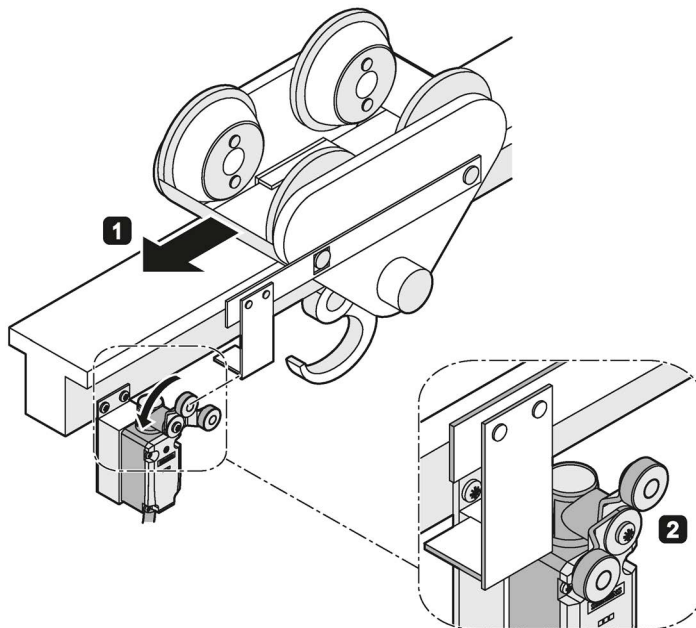

Application examples

- Cranes
- Crane trolleys

Notes on installation

- For reciprocating movements
- Can be operated in two directions
- Latching actuator

NOTICE

Risk of property damage.

The fork lever latches after actuation and must be reset.

Note

The actuator is not suitable for safety circuits.

Variants

Fork lever (Page 85) made of stainless steel or metal with plastic roller

Fork lever made of stainless steel or metal with metal roller

5.12 Application example - Hinge switch

Possible application of a hinge switch

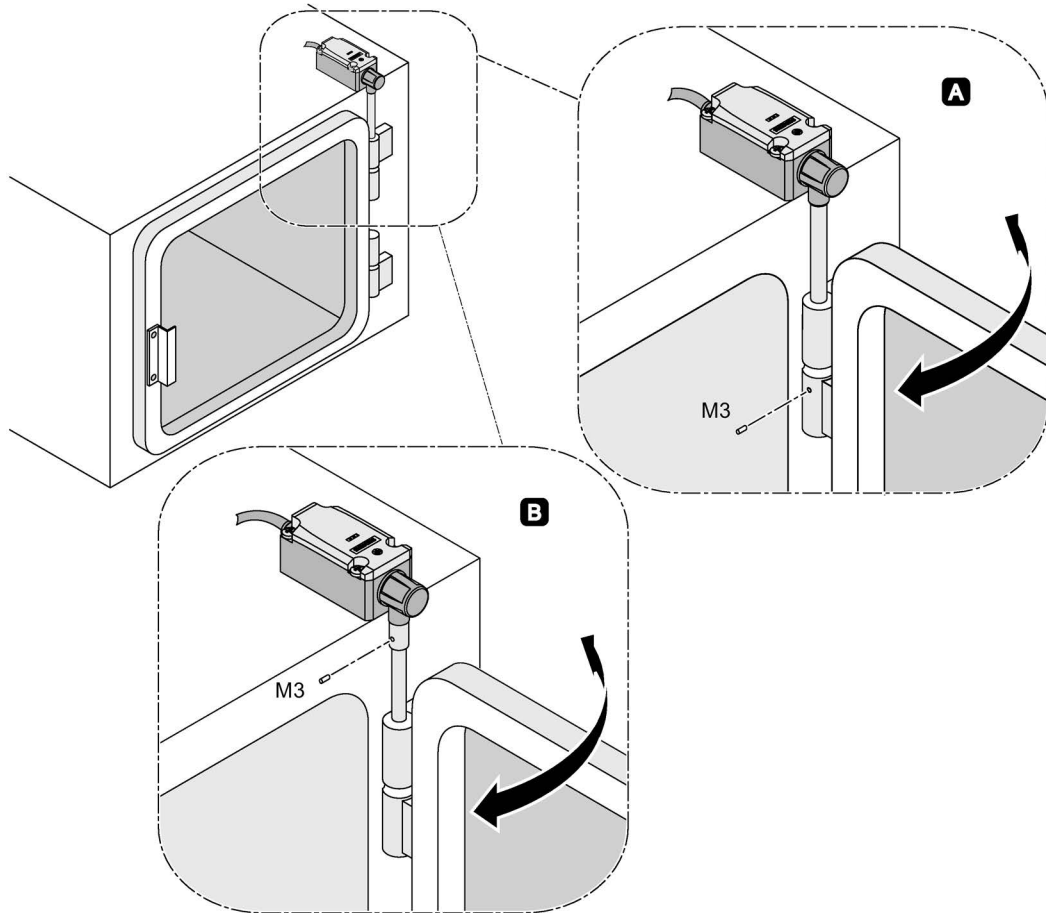

Application examples

- Hinged doors
- For monitoring of hinged doors and flaps, with a fixed positively-locking connection between the switch and door hinge.

Notes on installation

- For inserting into a hinge (solid shaft 3SE5112-0LU.)
- For inserting into a hinge pin (hollow shaft 3SE5232)
- Tamper proof
- Direct connection to the ASi network with a very low current load of ≤ 40 mA
- Default: 2 x 3 contacts

Variants

A

Actuator with solid shaft, diameter 10 mm

B

Actuator with hollow shaft, inside diameter 8 mm, outside diameter 12 mm

5.13 Application example of safety switch without tumbler

Possible application of a mechanical safety switch without tumbler

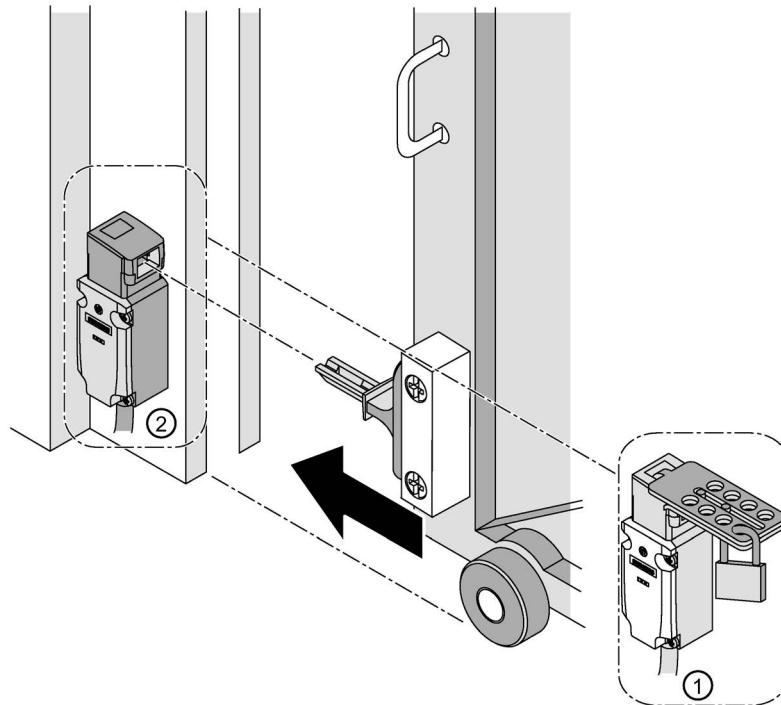

(1) With locking device: e.g., for protection against inadvertent actuation

(2) Without tumbler: e.g., for monitoring of protective doors

Application examples

- Rolling gates
- Position monitoring of doors, covers, or protective grilles (without tumbler)
- Additional interlock requirement, e.g., in the work zone of a robot system

Notes on installation

Note

For precise positioning of safety switches with separate actuator in the case of large, heavy protective doors, an insertion guide should be used.

- The safety switch can only be switched with the associated triple-coded actuator.
- The switch can be actuated on the face side and laterally.

NOTICE

Risk of property damage.

Do not use the safety switch as an endstop, as this may cause damage to the switch.

Variants

Safety switch with separate actuator without tumbler (Page 147)

Safety switch with separate actuator with tumbler (Page 155)

- Spring-locked
 - Auxiliary release
 - Key-operated release
 - Emergency release
 - Escape release
- Solenoid-locked
- Front escape release
- Rear escape release and front auxiliary release
- Rear emergency release and front auxiliary release

5.14 Application example of safety switch with tumbler

Possible application of a mechanical safety switch with tumbler

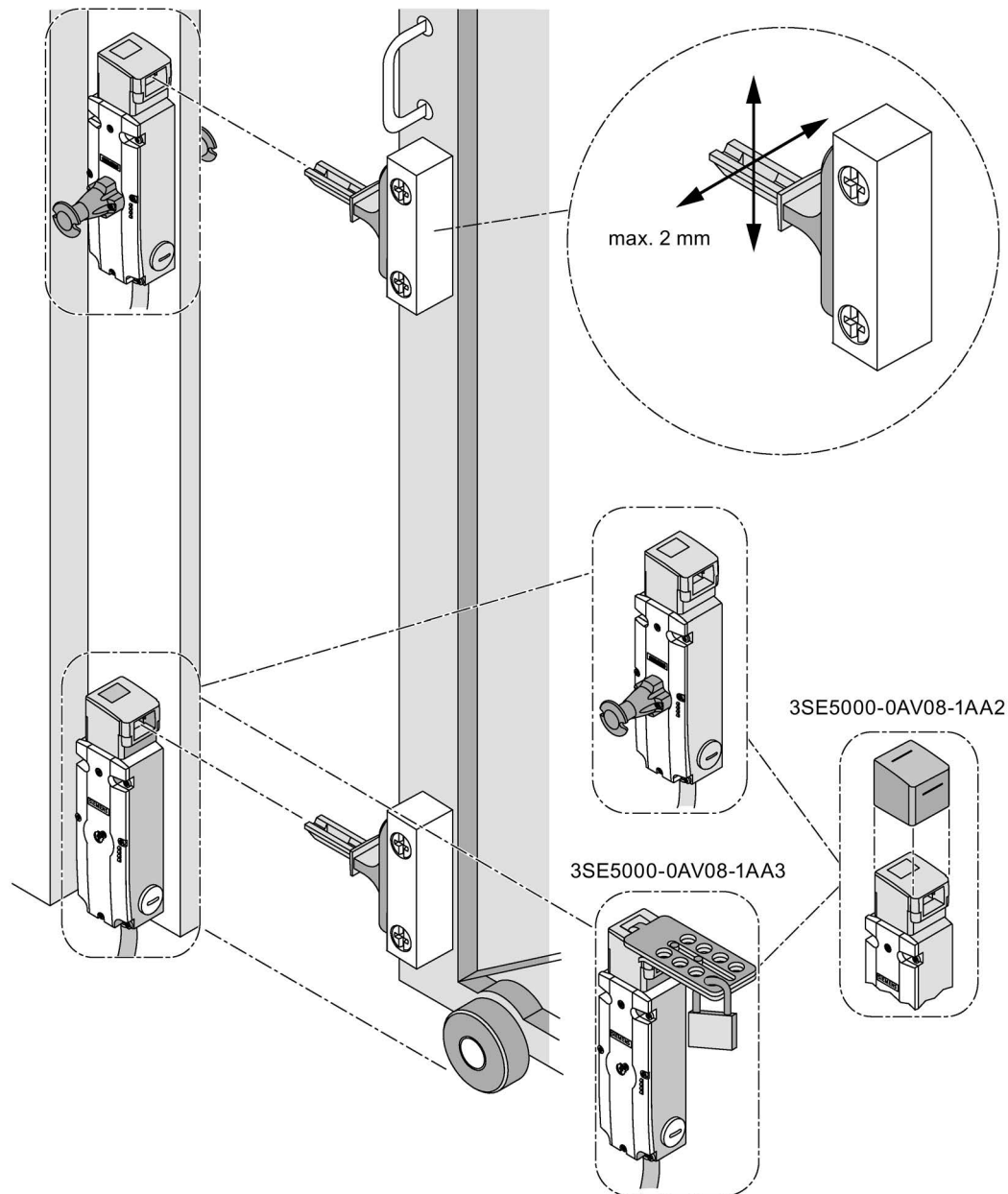

Note

Observe the offset of the actuator.

The actuator may have a maximum offset of 2 mm.

5.14 Application example of safety switch with tumbler

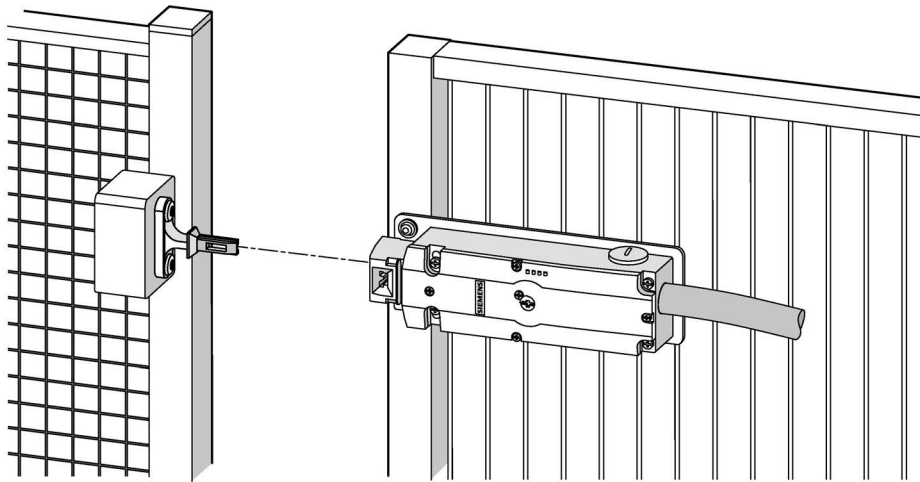

Note

Do not use the door as an endstop.

Note

Heavy doors

A guide must be created for the actuator if doors are heavy.

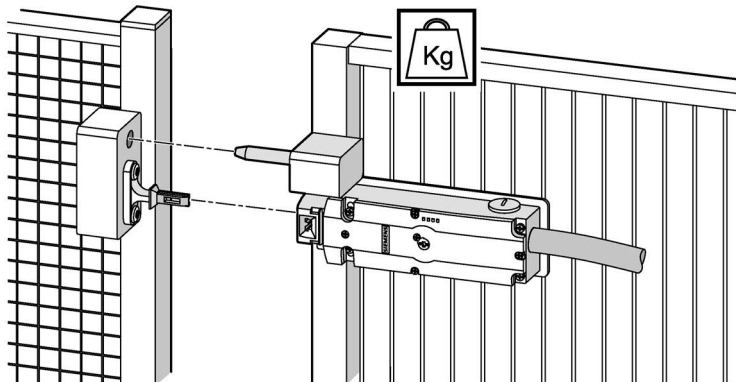

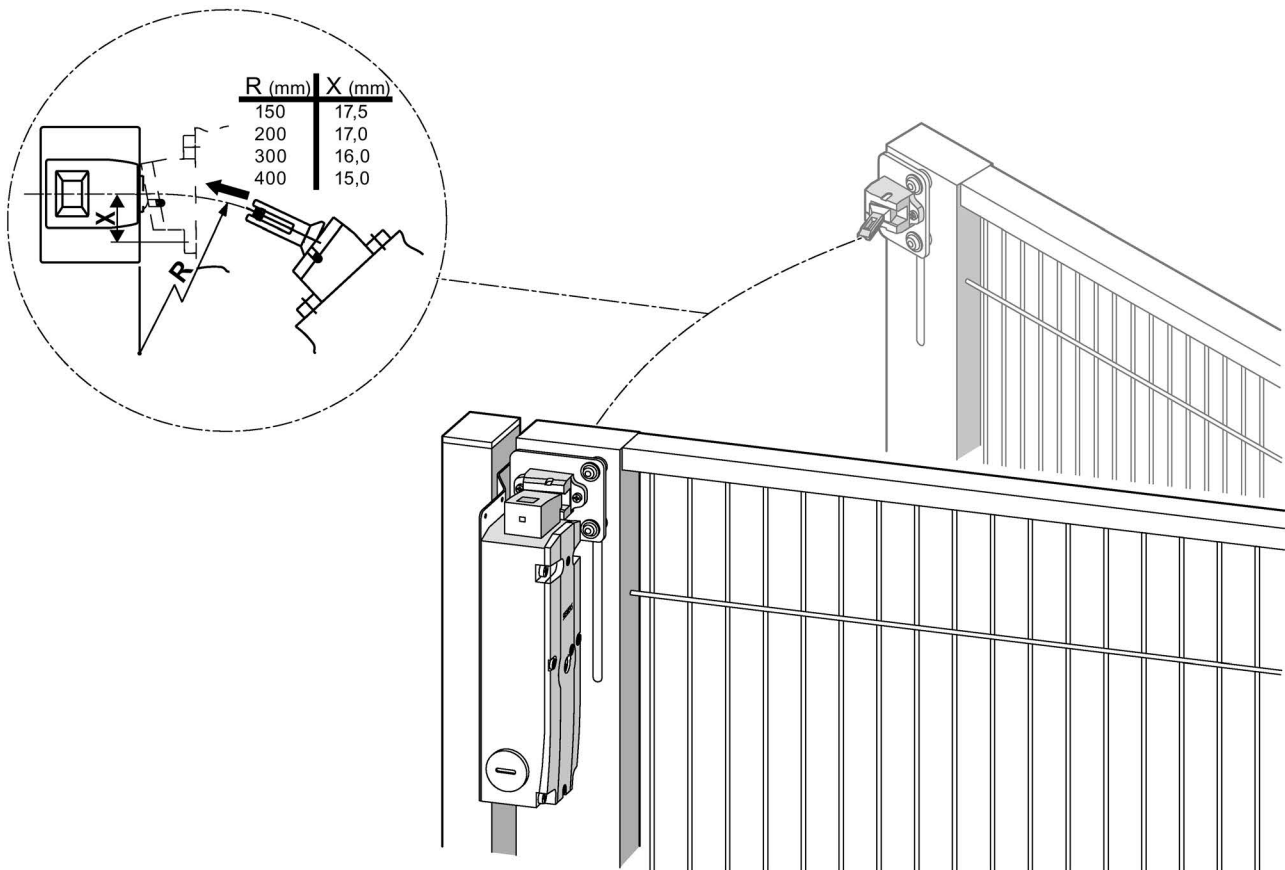

Application examples

- Protection of a work zone (with tumbler)
- Shutting down of machines requires that safety doors are closed (with tumbler)

5.15 Application example of a magnetically-operated switch

NOTICE

Install the sensor and actuator at the same height.

Ensure that you install the sensor and actuator at the same height so as to not affect the correct functioning of the magnetically operated switch.

Magnetic monitoring system 3SE66..-CA0. - sliding door

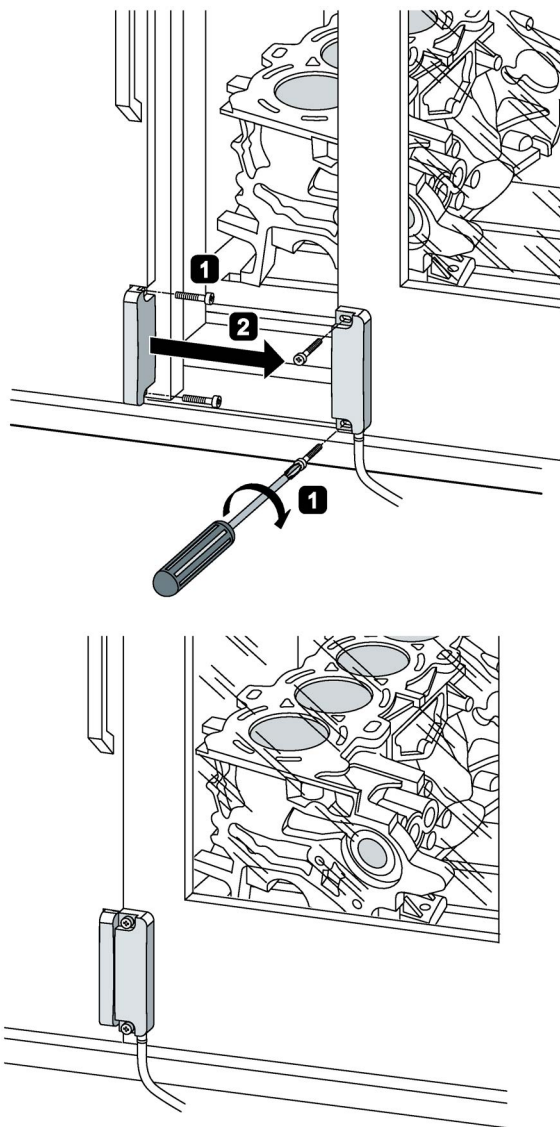

Magnetic monitoring system 3SE66...CA0. - swivel door

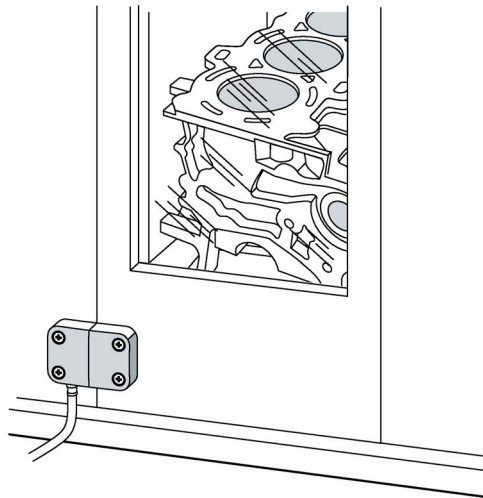
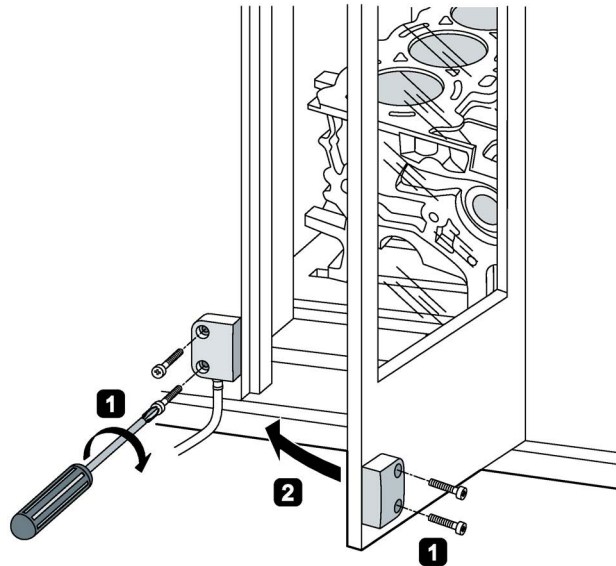

Non-contact magnetically-operated safety switches 3SE66...-BA

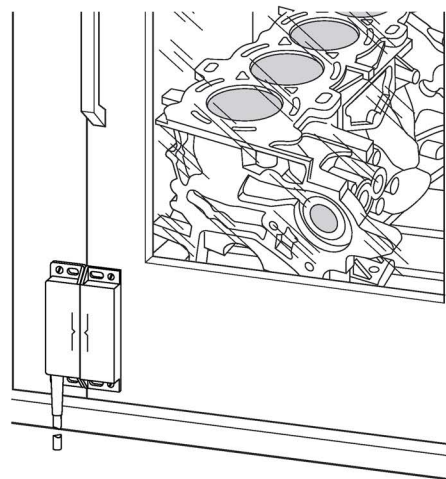
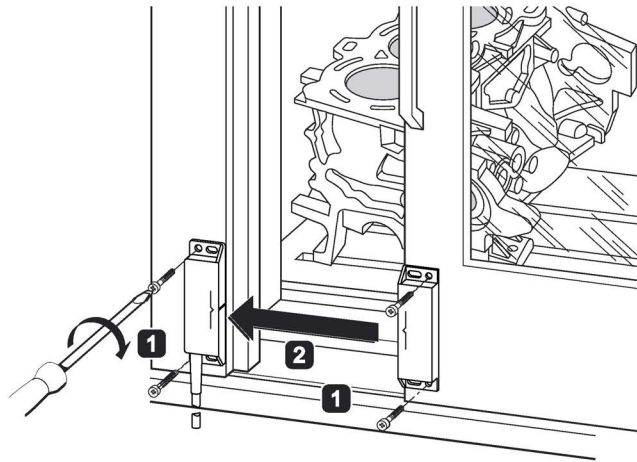

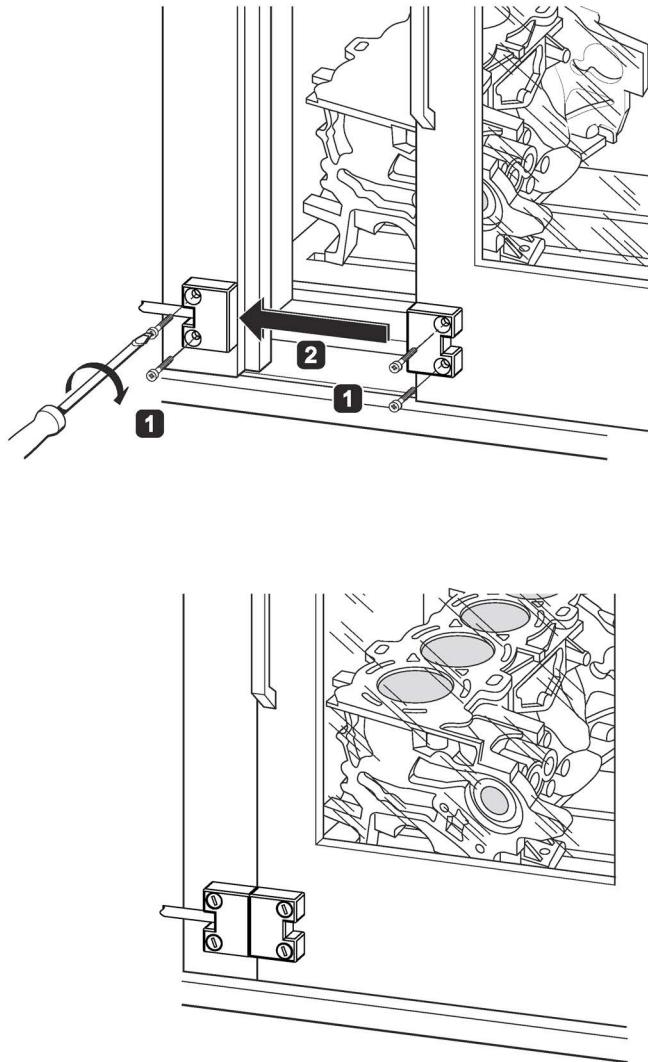

Application examples

- The magnetically-operated switch for use in safety circuits serves to monitor the positions of moving protective devices (covers, flaps or doors).
- The magnetically-operated switches are used in applications in which the hazardous state is ended without delay when the protective device is opened.

5.16 Special environmental requirements

5.16.1 Icing

Position switches must be mounted and, if necessary, protected in such a way that damage resulting from foreseeable influences is avoided.

- The interface and actuating element must be positioned so as to avoid condensation, water accumulation, or icing.
- Choose actuators that are less prone to icing (rotary instead of linear), such as a rod lever or twist lever.
- All basic designs without actuator are ideal since the plunger guide is sealed only by means of an external chlorinated rubber membrane.
- See also Humidity and wet conditions (Page 262)

5.16.2 UV radiation

The actuator interface of the complete 3SE5 series is sealed with a UV-resistant chlorinated rubber membrane.

Note

For purposes of long-term stability, make sure to mount the position switches in such a way that seals and plastics are protected against direct and extreme UV radiation.

5.16.3 Humidity and wet conditions

5.16.3.1 Condensation

Moisture in sealed enclosure

While enclosures tested according to IP standard are impervious to liquids, they are not gas-tight. Therefore, moisture can penetrate the enclosure in spite of degree of protection IP66 and IP67.

Wetness

Wetness refers to water in liquid state, e.g., rain.

Humidity

Humidity is water in gaseous state, e.g., micro-aerosols or water vapor.

Enclosures according to IP standards are impervious to liquids, but they are not permanently gas-tight. Therefore, while rain cannot penetrate the enclosure, water vapor can. If an underpressure is created in the enclosure, humid air can be drawn in. Underpressure or overpressure conditions form very quickly when an enclosure is used under open-air weather conditions. This moisture can no longer escape from the enclosure, where it accumulates and condenses.

Result

Short-circuit and corrosion

The more often the enclosure is exposed to temperature change cycles, the more moisture is transported into the enclosure. This is due to the fact that each temperature cycle places a constant load on the seals, whose function may be impaired due to abrasion and stress cracks.

Remedy, measures

- Separate protective cover over enclosure, protective canopy

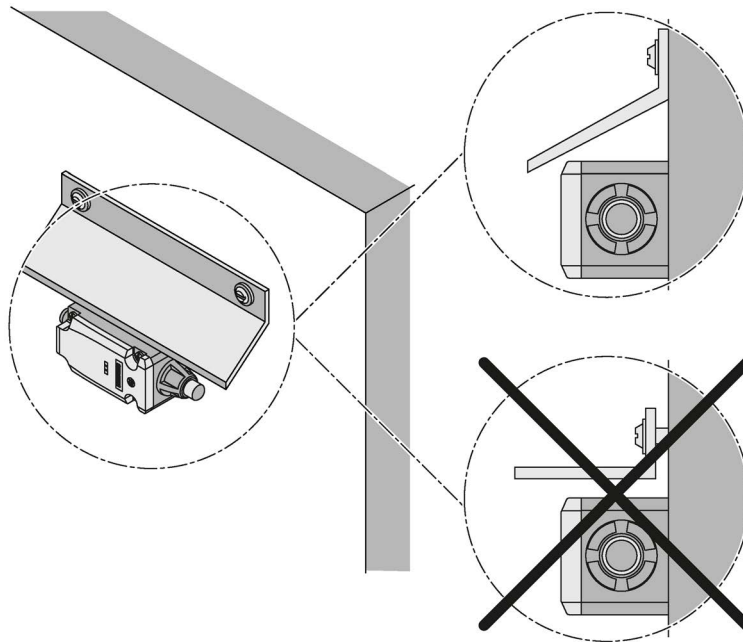

NOTICE

Risk of property damage

Ensure the following when installing protective canopies:

- The interface and actuating element must be positioned so as to avoid water accumulation.
- The protective canopy must be adequately sealed.
- The protective canopy must have an adequate projection and slope.

5.16.3.2 Water jet

Protection against water jets

- The switches have degree of protection IP65 or IP66 and are therefore protected against water jets. When high-pressure cleaners are used frequently, protection must be provided for the installation (e.g., in the case of cleaning operations in the food and beverage industry).
- The interface and actuating element must be positioned so as to avoid water accumulation.

5.16.3.3 Immersing

Switches with degree of protection IP67 can be immersed for 1 hour in water up to 1 m deep. In this case, attention must be paid that the threaded caps (cable gland) fit tightly.

5.16.4 Dust, dirt, oil

Note**Avoidance of dirt.**

Ensure that the switch is attached in such a way that accumulation of dirt in the interface is avoided.

5.16.5 Cleaning agent, chemical environment

NOTICE**Risk of property damage.****Cleaning agents can make devices sticky.**

Ensure that the switch is attached in such a way that accumulation of cleaning agents in the interface is avoided. This can cause linear guides (e.g., rounded plunger, roller plunger) to become sticky.

Extremely aggressive cleaning agents can attack and damage seals.

5.16.6 Extreme temperatures

Versions down to -40 °C

Versions that are suitable for ambient temperatures down to -40 °C can be ordered with the qualifiers -1AJ0, -1AJ1 (in accordance with rail standard EN 61373) or -1AY0 (e.g. 3SE5232-0LE10-1AY0). These switches are characterized by their use of special sealing materials as well as low-temperature greases.

Application

- In external areas, e.g., for crane systems, train applications, etc.

Installation in cooling systems

When the switches are installed in or on cooling systems, increased condensation may occur. When the doors are opened, warm, moist air flowing in condenses and can cause icing on the switches.

Recommendation

Mount the switch outside the cooling chamber or install with a cover (see Section Icing (Page 262)).

5.17 Protecting against change in position

Securing against change of position (fixing)

- When used as a safety switch, ensure that the enclosure and mounting plane are fastened with positive locking.
- When oblong holes are used for mounting, dowel pins or stops must also be used.

Appendix

A.1 Standards and approvals

A.1.1 Standards for mechanical position switches

SIRIUS position switches are developed and manufactured according to product standard DIN EN / IEC 60947-5-1. The SIRIUS position switches also meet the requirements of DIN EN 50041 and DIN EN 50047 and thus help you to comply with the specifications when designing your machines.

All modules/devices marked with the positive-opening symbol can be used in safety circuits.

DIN EN / IEC 60204-1:

This part of IEC 60204 contains requirements and recommendations for electrical equipment of machines, in order to:

- promote the safety of persons and property
- maintain correct functioning
- simplify service and maintenance

For example, mechanically actuated position switches (travel sensors used for safety purposes must be provided with a positive-opening normally-closed contact).

DIN EN / IEC 60947-5-1

This standard applies to control devices and contact blocks intended for controlling, signaling, interlocking, and so on, of switching devices and switchgear, especially position switches, e.g., auxiliary switches actuated by a machine part or a mechanism.

Requirements for the design and behavior of the auxiliary switches are described.

DIN EN ISO 14119

This standard defines guidelines for the design and selection of interlocking devices associated with guards. It describes designs of locking facilities.

A.1.2 General information regarding dimensions and characteristic values for position switches

These standards describe the mountings and operating points of position switches.

DIN EN 50041 - Control switches; position switches 42.5 x 80

This standard applies to certain position switches with automatically resetting actuator elements for industrial application, whose standard dimensions and required characteristic values for use are specified in the following.

The electrical values must conform to DIN EN / IEC 60947-5-1.

This standard includes the following 6 types:

- With twist lever (type A)
- With rounded plunger (type B)
- With roller plunger (type C)
- With rod lever (type D)
- Lateral actuator with rounded plunger (type F)
- Lateral actuator with rounded plunger (type G)

The devices are designed with snap-action or slow-action function.

DIN EN 50047 - Control switches; position switches 30 x 55

This standard applies to certain position switches with automatically resetting actuator elements for industrial application, whose standard dimensions and required characteristic values for use are specified in the following.

The electrical values must conform to DIN EN / IEC 60947-5-1.

This standard includes the following 4 types:

- With twist lever (type A)
- With rounded plunger (type B)
- With roller plunger (type C)
- With roller lever (type E)

The devices are designed with snap-action or slow-action function.

A.2 Description of the degrees of protection

Degree of protection

The protection of position switches against ingress of solid foreign objects and liquids must be appropriate, taking into consideration the external influences under which the switch is operated (e.g., dust, coolant, and metal chips).

Examples of minimum degrees of protection

| | |
|---|----------------------|
| General industrial applications | IP32, IP43, and IP54 |
| Building site areas | IP54 |
| Enclosure that is cleaned with low-pressure water jet | IP55 |
| Enclosure that guarantees protection against fine dust. | IP65 |

IPX5, IPX6, and IPX7 do not mean that an interlocking device may be sprayed, e.g., with a hose or high-pressure cleaning unit. Additional protective measures must be taken in this case.

A marking in which the second digit is "7" or "8" (e.g., IP67) does not necessarily mean that the requirements for degrees of protection in which the second digit is "5" or "6" (e.g., IP65) are met.

Excerpt from DIN EN 60529 "IP degrees of protection; protection against contact, foreign objects, and water for electrical equipment"

| First code number | Degrees of protection (protection against contact and solid foreign objects) |
|--------------------|---|
| 5 | Ingress of dust is not totally prevented, but dust must not be allowed to enter in such quantities that satisfactory operation of the device or safety is impaired. |
| 6 | No ingress of dust |
| Second code number | Degrees of protection (water protection) |
| 4 | Water splashing onto the enclosure from any direction must not have a harmful effect. |
| 5 | A jet of water directed at the enclosure from any direction must not have a harmful effect. |
| 6 | A strong jet of water directed at the enclosure from any direction must not have a harmful effect. |
| 7 | Water must not enter in an amount that causes harmful effects if the enclosure is submerged in water temporarily under standardized pressure and time conditions. |

Components of the IP code and their meaning

| Component: | Digits or letters | Meaning for protection of equipment : | Meaning for protection of persons : |
|--------------------|-------------------|---|--|
| Code letters | IP | — | — |
| First code number | | Ingress of solid foreign bodies | Access to dangerous parts with |
| | 0 | (Not protected) | (Not protected) |
| | 1 | ≥ 50 mm diameter | Back of hand |
| | 2 | ≥ 12.5 mm diameter | Finger |
| | 3 | ≥ 2.5 mm diameter | Tool |
| | 4 | ≥ 1.0 mm diameter | Wire |
| | 5 | Dust protected | Wire |
| | 6 | Dust-tight | Wire |
| | | Ingress of water with harmful effects | |
| Second code number | 0 | (Not protected) | — |
| | 1 | Protected against vertical dripping water | |
| | 2 | Protected against dripping water (15° inclination) | |
| | 3 | Protected against spray water | |
| | 4 | Protected against splash water | |
| | 5 | Protected against jet-water | |
| | 6 | Protected against intense jet-water | |
| | 7 | Protected against the effects of temporary immersion in water | |
| | 8 | Protected against the effects of continuous immersion in water | |
| | 9 | Protected against high pressure and high jet-water temperatures | |

Index

3

3D model, 12

A

Actuation time, 71

Actuator head

Position switches in compact design, 58

Actuator type

Adjustable-length rod lever, 84

Adjustable-length twist lever with pre-drilled holes, 83

Angular roller lever, 76

Fork lever, 85

Plain plunger, 72, 72

Roller lever, 75

Roller plunger, 73

Roller plunger for central fixing, 74

Rounded plunger, 72, 72

Spring rod, 77

Actuator types

Mechanical position switches, 71

Adjustable-length rod lever, 84

Adjustable-length twist lever with pre-drilled holes, 83

Angular roller lever, 76

App

Siemens Industry Online Support, 14

Application areas, 19

Article No. scheme

Position switch, 40

Auxiliary release, 158, 160, 219

with lock, 161

C

Calculation example

Failure rate, 20

CAX data, 12

Certificates, 15

Chlorinated rubber membrane, 39, 262

Closed-circuit principle, 220

Compact design

Connector, 53

Molded cable, 53

Configuration

Ordering dialog, 45

Configurator, 41, 42

Contact block

2-pin, 87

3-pin, 87

Contact blocks, 49

Contact reliability, 38

Contacts, 87

D

Degree of protection

Contact blocks, 41

Open-type position switches, 40

Position switch, 40

Separate actuation, 41

Dimension drawings, 12

Documentation

History, 10

Required knowledge, 9

Target group, 9

E

Emergency release, 158, 161, 219

Enclosure sizes

Compact design, 53

Hinge switches, 178

Mechanical position switches, 70

EPLAN macros, 12

Escape release, 158, 219

Front, 161

Rear, 162

F

Failure rates, 19

Fork lever, 85

H

Hinge switches, 177

Enclosure sizes, 178

History, 10

- I**
- Icing, 262
 - Industry Mall, 13
 - Insertion guide, 157
 - Interlock
 - Auxiliary release, 160
 - Emergency release, 161
 - Key-operated release, 161
 - Solenoid-locked, 158, 219
 - Interlock types, 158, 219
 - Internet addresses
 - Brochures, 13
 - Catalogs, 13
 - Industry Mall, 13
 - Online configurator, 13
- K**
- Key-operated release, 158, 161, 219
- L**
- LED display
 - Safety switch AS-Interface, 209, 213
 - Separate actuator with tumbler, 220
 - LED module
 - Rotation, 69
 - LED signaling indicator
 - Mechanical position switches, 68
- M**
- magnetically operated safety switch, 185
 - Mechanical position switches
 - Actuator types, 71
 - Actuator variants, 70
 - Actuators, 71
 - Design, 70
 - Enclosure sizes, 70
 - Enclosure versions, 70
 - Metal enclosures, 65
 - Modular system, 63
 - Plastic enclosures, 63
 - Membranes, 39
 - Modular system
 - Mechanical position switches, 63
 - Molded cable
 - Compact design, 53
 - Monitoring unit, 35
- N**
- non-contact safety switch, 185
- O**
- Online configurator, 41
 - Open-circuit principle, 220
 - Overtravel, 39
 - Overview
 - 3SE22 safety switches, 27
 - 3SE5 safety switches, 26
 - AS-i safety switches, 28
 - Hinge switches, 29
 - Mechanical position switches, 24, 25
 - Non-contact magnetically operated safety switches, 31
 - Open-type position switch, 21
 - Position switches in compact design, 21
- P**
- Plain plunger, 72, 72
 - Position switch, 40
 - Compact design, 53
 - Overview, 24, 25
 - Types, 40
 - Position switches in compact design
 - Rotating the actuator head, 58
 - Position switches in open-type design, 48
 - Positive opening operation, 36, 38, 38, 38
- R**
- Release variants, 158, 219
 - Required knowledge, 9
 - Risk analysis, 158, 219
 - Roller lever, 75
 - Roller plunger, 73
 - Roller plunger for central fixing, 74
 - Rounded plunger, 72, 72
- S**
- Safety relay, 35
 - safety switch
 - magnetic, 185
 - non-contact, 185
 - Safety switch
 - Actuation, 157
 - with tumbler, 157

- Selection guide, 41
- Separate actuator
 - Dust protection, 146
 - Locking device, 145
 - Radius actuator, 142
- Siemens Industry Online Support
 - Certificates, 15
- Silicone membrane, 39
- Slow-action function, 38, 38
 - With make-before-break, 38
- SN 31920 standard, 20
- Snap-action function, 38, 38
- Solenoid lock, 158, 158, 219, 219, 220
- Spring lock, 158, 219, 220
- Spring rod, 77

T

- Target group, 9
- Technical Assistance, 14
- Tumbler
 - Solenoid-locked, 221

