

SIEMENS

Ingenuity for life

24/7

Industry Online Support

Home

Fail-Safe Group Shutdown of the ET 200SP F-Motor Starter with F-DQ

SIMATIC Safety Integrated

<https://support.industry.siemens.com/cs/ww/en/view/109748128>

Siemens
Industry
Online
Support



Warranty and Liability

Note

The Application Examples are not binding and do not claim to be complete regarding the circuits shown, equipping and any eventuality. The Application Examples do not represent customer-specific solutions. They are only intended to provide support for typical applications. You are responsible for ensuring that the described products are used correctly. These Application Examples do not relieve you of the responsibility to use safe practices in application, installation, operation and maintenance. When using these Application Examples, you recognize that we cannot be made liable for any damage/claims beyond the liability clause described. We reserve the right to make changes to these Application Examples at any time without prior notice.

If there are any deviations between the recommendations provided in these Application Examples and other Siemens publications – e.g. Catalogs – the contents of the other documents have priority.

We do not accept any liability for the information contained in this document. Any claims against us – based on whatever legal reason – resulting from the use of the examples, information, programs, engineering and performance data etc., described in this Application Example shall be excluded. Such an exclusion shall not apply in the case of mandatory liability, e.g. under the German Product Liability Act (“Produkthaftungsgesetz”), in case of intent, gross negligence, or injury of life, body or health, guarantee for the quality of a product, fraudulent concealment of a deficiency or breach of a condition which goes to the root of the contract (“wesentliche Vertragspflichten”). The damages for a breach of a substantial contractual obligation are, however, limited to the foreseeable damage, typical for the type of contract, except in the event of intent or gross negligence or injury to life, body or health. The above provisions do not imply a change of the burden of proof to your detriment.

Any form of duplication or distribution of these Application Examples or excerpts hereof is prohibited without the expressed consent of the Siemens AG.

Security information

Siemens provides products and solutions with industrial security functions that support the secure operation of plants, systems, machines and networks. In order to protect plants, systems, machines and networks against cyber threats, it is necessary to implement – and continuously maintain – a holistic, state-of-the-art industrial security concept. Siemens’ products and solutions only form one element of such a concept.

Customer is responsible to prevent unauthorized access to its plants, systems, machines and networks. Systems, machines and components should only be connected to the enterprise network or the internet if and to the extent necessary and with appropriate security measures (e.g. use of firewalls and network segmentation) in place.

Additionally, Siemens’ guidance on appropriate security measures should be taken into account. For more information about industrial security, please visit <http://www.siemens.com/industrialsecurity>.

Siemens’ products and solutions undergo continuous development to make them more secure. Siemens strongly recommends to apply product updates as soon as available and to always use the latest product versions. Use of product versions that are no longer supported, and failure to apply latest updates may increase customer’s exposure to cyber threats.

To stay informed about product updates, subscribe to the Siemens Industrial Security RSS Feed under <http://www.siemens.com/industrialsecurity>.

Table of Contents

	Warranty and Liability	2
1	Task.....	4
2	Solution.....	5
2.1	Overview.....	5
2.2	Hardware and software components	6
2.2.1	Validity	6
2.2.2	Components used	6
2.2.3	Sample files and projects	7
3	Hardware configuration	8
3.1	Shutdown options	8
3.2	Mode of operation	9
3.3	Wiring example.....	11
4	Configuration and Project Engineering.....	12
4.1	Hardware configuration	12
4.2	Module parameters	13
4.3	First commissioning.....	16
5	Mode of Operation	17
5.1	Complete overview	17
5.2	Safety program	17
5.3	Operational switching of the motor starter	19
6	Diagnostics	21
7	Links & Literature	22
8	History.....	22

1 Task

A machine is operated with different actuators. To protect the operating staff, these actuators are monitored in a fail-safe controller and shut down through technical protective measures (e.g., emergency stop command device) in the event of danger.

This application example shows you how to safely shut down one or more actuators with the ET 200SP F-motor starter in combination with ET 200SP F-DI and F-DQ fail-safe input and output modules. The application example described in this document meets the requirements of IEC 62061 (SIL 3) and ISO 13849-1 (PL e).

2 Solution

2.1 Overview

Group shutdown is the simultaneous shutdown of multiple actuators with one shutdown signal. Fail-safe group shutdown means that the shutdown signal is triggered by a safety function (e.g., emergency stop). All the actuators integrated in a group shut down simultaneously.

Configuration of the application example

Figure 2-1:

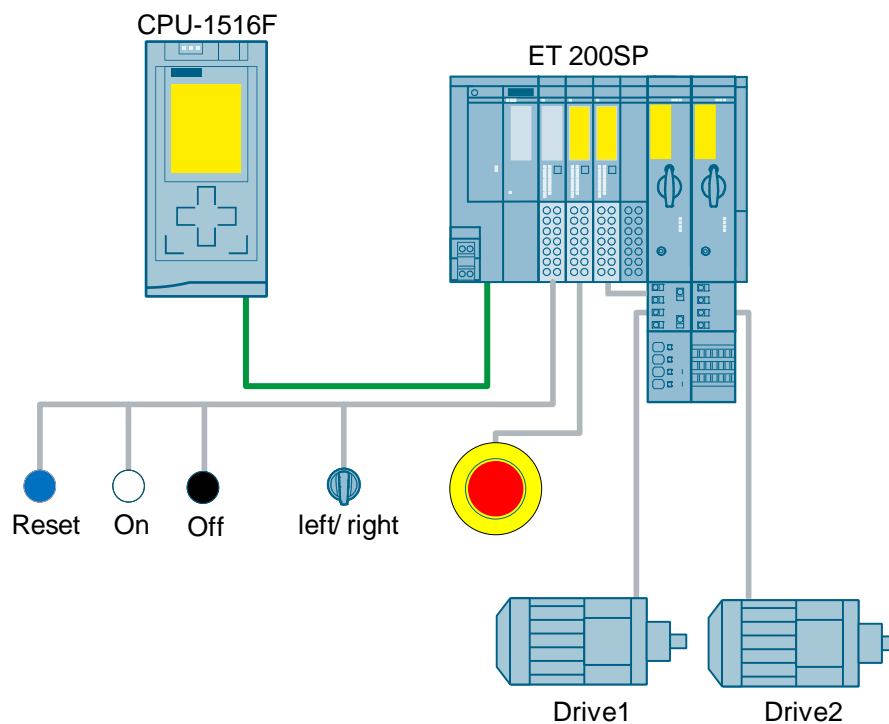

Required knowledge

The following knowledge is required:

- Basics of functional safety
- Basics of STEP 7 programming

2.2 Hardware and software components

2.2.1 Validity

This application example is valid for:

- All fail-safe SIMATIC controllers
- STEP 7 Professional V14 or higher with STEP 7 Safety Advanced

2.2.2 Components used

The application example was created with the following components:

Table 2-1 Hardware components

Component	No.	Article no.	Note
Power supply	1	6EP1332-4BA00	PM 70W
Fail-safe S7 CPU	1	6ES7516-3FN00-0AB0	CPU 1516F-3 PN/DP
SIMATIC Memory Card	1	6ES7954-8LC02-0AA0	SMC 4MB
Interface module for ET 200SP	1	6ES7155-6AU00-0BN0	IM155-6PN ST
Digital input module	1	6ES7131-6BF00-0CA0	DI 8X24VDC HF
Base unit	1	6ES7193-6BP00-0DA0	Infeed terminal separated
Fail-safe input module	1	6ES7136-6BA00-0CA0	F-DI 8x24VDC HF
Base unit	1	6ES7193-6BP00-0BA0	Infeed terminal bridged
Fail-safe output module	1	6ES7136-6DC00-0CA0	F-DQ 8X24VDC/0.5A PP
Base unit	1	6ES7193-6BP00-0BA0	Infeed terminal bridged
Empty module cover	1	6ES7133-6CV15-1AM0	15mm base unit cover
Base unit empty module	1	6ES7193-6BP00-0BA0	Infeed terminal bridged
ET 200SP F-motor starter	1	3RK1308-0CC00-0CP0	F-direct-on-line starter 0.9-3A
Base unit with F-DI infeed	1	3RK1908-0AP00-0GP0	BU for ET 200SP motor starter with 500V infeed, MS7
ET 200SP F-motor starter	1	3RK1308-0DC00-0CP0	F-reversing starter 0.9-3A
Base unit with F-DI forwarding	1	3RK1908-0AP00-0JP0	BU for ET 200SP motor starter without infeed, MS9
Server module	1	6ES7193-6PA00-0AA0	ET 200SP, server module
Emergency stop command device, complete unit	1	3SU1150-1HB20-1CH0	Mushroom pushbutton with one normally closed contact
Contact module, one NC	1	3SU1400-2AA10-1CA0	Second contact for emergency stop
Reset pushbutton, complete unit	1	3SU1150-0AB50-1BA0	Pushbutton, blue, one normally open contact
On pushbutton, complete unit	1	3SU1150-0AB50-1BA0	Pushbutton, white, one normally open contact
Off pushbutton, complete unit	1	3SU1150-0AB10-1BA0	Pushbutton, black, one normally open contact
Selector switch, left/right, complete unit	1	3SU1150-2BL60-1NA0	Selector switch, white, three switch positions I-O-II, latching, two normally open contacts

2 Solution

Table 2-2 Software components

Component	No.	Article no.	Note
STEP 7 Professional	1	6ES7822-1AE04-0YA5	V15.1
STEP 7 Safety Advanced	1	6ES7833-1FA14-0YH5	V15.1
Hardware Support Package	1	HSP0195 – SIMATIC ET 200SP motor starter (not required for V15 and higher)	https://support.industry.siemens.com/cs/ww/en/view/72341852

2.2.3 Sample files and projects

The following list contains all files and projects that are used in this application example.

Table 2-3 2.2.3 Sample files and projects

Component	Note
109748128_ET200SP_F-DQ_DOC_v10_en.docx	This document
109748128_ET_200SP_with_F-DQ_PROG.zip	TIA Portal project

3 Hardware configuration

3.1 Shutdown options

ET 200SP motor starters are offered in two versions, standard and fail-safe, each available as a direct-on-line starter and as a reversing starter.

Depending on the application example, the ET 200SP F-motor starter can be safely shut down in different ways, for example

- with a 3SK safety relay,
- an ET 200SP F-DQ fail-safe digital output module or
- an ET 200SP F-PM E fail-safe power module.

The below selection matrix illustrates the different shutdown options.

Table 3-1 Shutdown options

ET 200SP F-motor starter shutdown principle		Application example with 3SK safety relay	Application example with F-DQ fail-safe digital output	Application example with F-PM-E fail-safe power module
Hardware diversity	Suitable for group shutdown	Yes	Yes	Yes
	Suitable for single shutdown	Yes	Yes	No
Use for cyclically requested safety functions (e.g., safety door, light curtain)		Yes	Yes	No
Use for acyclically requested safety functions (e.g., emergency stop)		Yes	Yes	Yes
Motor starter can still be accessed by the CPU after fail-safe shutdown		Yes	Yes	No
Suitable for immediate ready for operation again		Yes	Yes	No (recovery time: $\geq 2.2s$)
External wiring overhead		Yes	Yes	No
Standard and safety technology		Separate	Integrated in one device	Integrated in one device

3.2 Mode of operation

The following example explains safe group shutdown with an S7-1500F-CPU and a distributed ET 200SP station. Fail-safe (group) shutdown is implemented combining the ET 200SP F-DI and F-DQ (fail-safe input and output modules) and ET 200SP F-motor starters. Safe shutdown is triggered by the emergency stop command device.

The emergency stop is read via the F-DI and then safely shuts down the F-DQ. The F-DQ, in turn, is interconnected with the F-DI of the F-motor starter and safely shuts down the motor starter. If you have only one emergency stop, you can connect one F-DQ to multiple F-motor starters (group shutdown) or you can use the base unit MS9 with bridged F-DI (in combination with MS7). However, e.g., when there are several emergency stop circuits, you can also use a separate F-DQ for each F-motor starter.

The advantage over group shutdown with an F-PM-E (fail-safe power module) is that communication between the F-motor starters and the CPU is maintained.

In this example, the group is set up with two fail-safe motor starters, one direct-on-line starter and one reversing starter. The use of more motor starters or the maximum configuration depends on the load voltage conditions. Follow the instructions provided in the “Manual – SIMATIC ET 200SP Motor Starter”:

<https://support.industry.siemens.com/cs/ww/en/view/109479973>

Note

By using the base units BU30-MS7 to BU30-MS10 a group shutdown can be realized with the help of their F-DI terminal. A group shutdown with these base units in SIL 3 / KAT 4 / PL e is only possible when using PP-switching failsafe output modules.

Slot rules

Trouble-free use of the ET 200SP motor starter requires that you use an empty module in front of the first motor starter.

For more information about setting up a plant with the ET 200SP motor starter, please refer to the “SIMATIC ET 200SP Distributed I/O System” system manual:

<https://support.industry.siemens.com/cs/ww/en/view/58649293>

Note

Protecting the lines from the feeding point to the motor starter requires additional measures such as a 3RV circuit breaker. As this is not part of functional safety, this is not included in the following overviews and connection diagrams.

It is also possible to implement an application with the ET 200SP F-motor starter according to the requirements of SIL 1 to SIL 2 (according to IEC 62061) or PL a to PL d (according to ISO 13849-1). In your design of the safety function, make sure to comply with the architecture of the required safety integrity level.

Monitoring the feedback circuit

For the ET 200SP fail-safe motor starter 3RK1308-0**00-0CP0, the OFF state is defined as a safe state. The motor starters are self-monitoring in compliance with SILCL 3 / PL e; therefore, it is not necessary to monitor them in the feedback circuit of the upstream evaluation unit.

If an error occurs, the motor starter itself prevents a restart.

Different base unit types (BU30 MS1 to MS10) are available for the ET 200SP motor starter. In this example, shutdown is implemented with the MS7 and MS9 types. The motor starters are supplied by the 24 V DC infeed of the left modules. The 400 V infeed of the actuators is connected to the MS7 base unit of the motor starter inserted first. Due to the use of the MS9 base unit, the 400 V infeed is bridged by MS7 and does not need to be reconnected. The base unit MS7 feature an F-DI that is connected, for example, to an F-DQ. Due to the use of the MS9 base unit, the F-DI infeed is bridged by MS7 and does not need to be reconnected.

3 Hardware configuration

3.3 Wiring example

Figure 3-1 Application example wiring

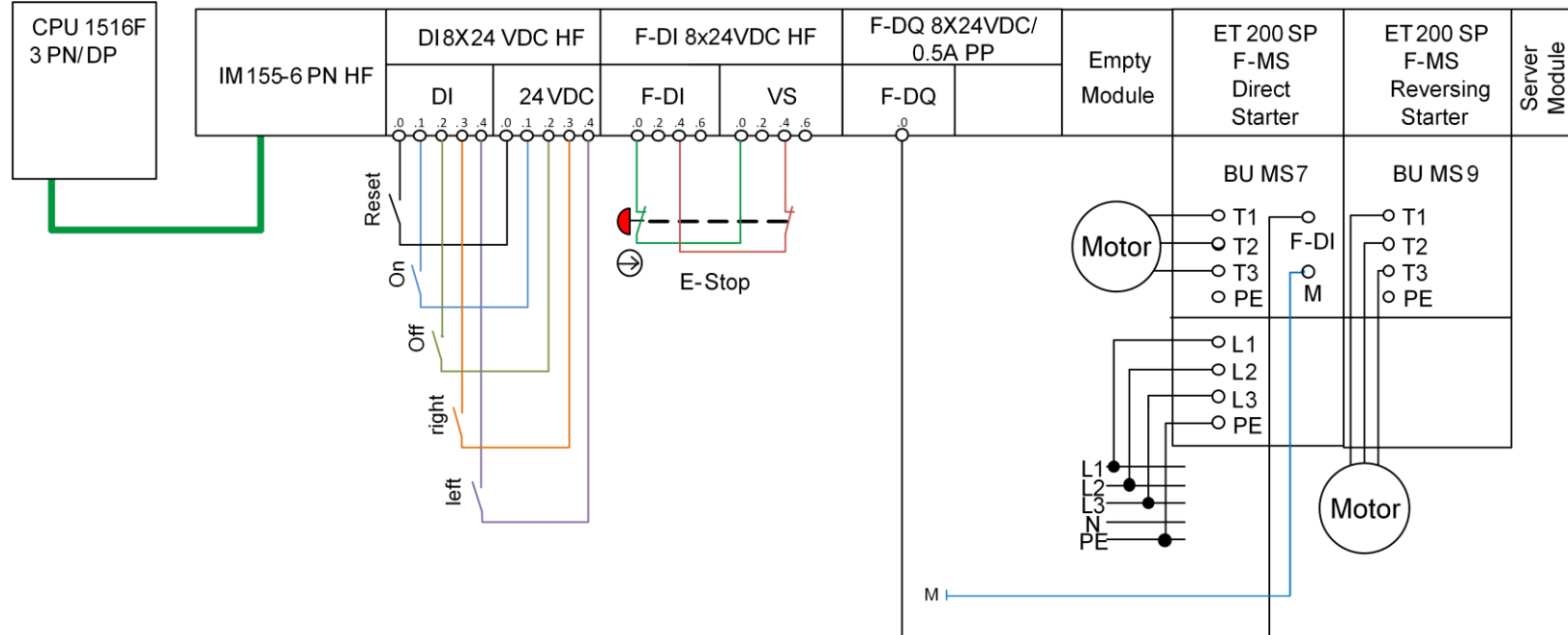

Note

The frame potentials of the motor starter base units must have the same frame potential as the ET 200SP station.

4 Configuration and Project Engineering

4.1 Hardware configuration

The supplied project does not require any further configuration. If you reproduce the application example with other components, this chapter shows the most important settings.

NOTICE The settings shown below help meet PL e / SIL 3. Changes to the settings can lead to a reduction or loss of the safety function.

NOTICE The defaults used in this sample project may differ from your specific requirements.

Figure 4-1 Hardware configuration

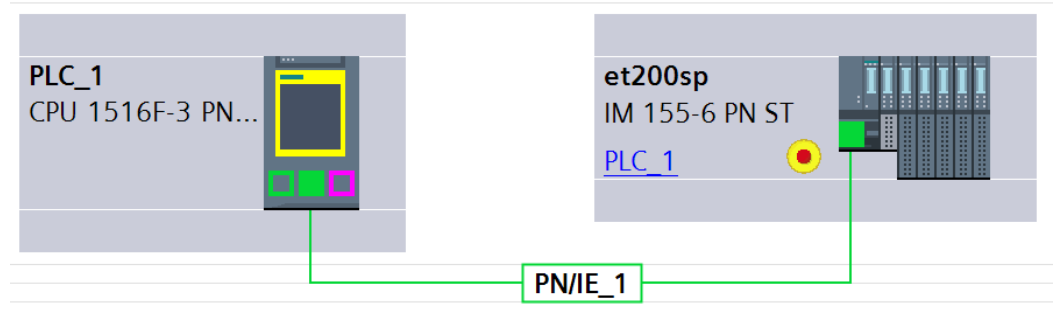
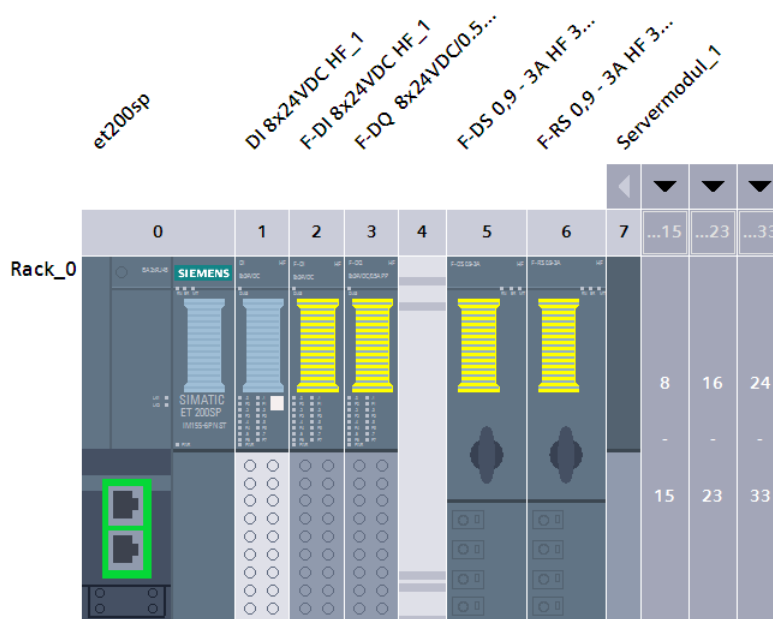

Figure 4-2 ET 200SP station configuration



4.2 Module parameters

F-DI module settings

Activate channel 0 and channel 4 on the F-DI for reading the emergency stop safety function. Both channels are supplied by the sensor supply on the F-DI.

Figure 4-3 F-DI settings, channel 0, 4

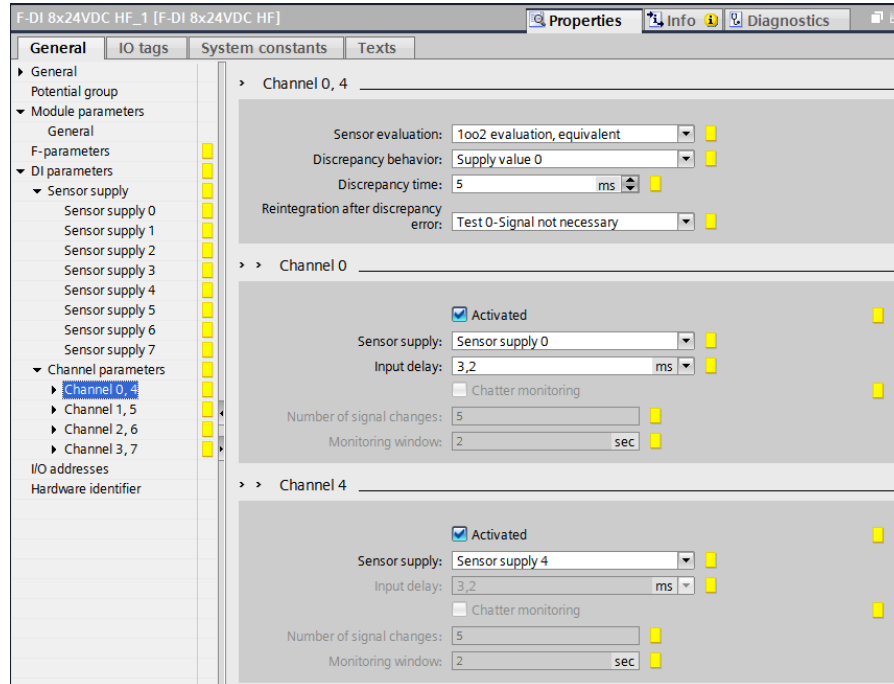

Activate the short-circuit test for the sensor supply of channels 0 and 4.

Figure 4-4 Sensor supply settings

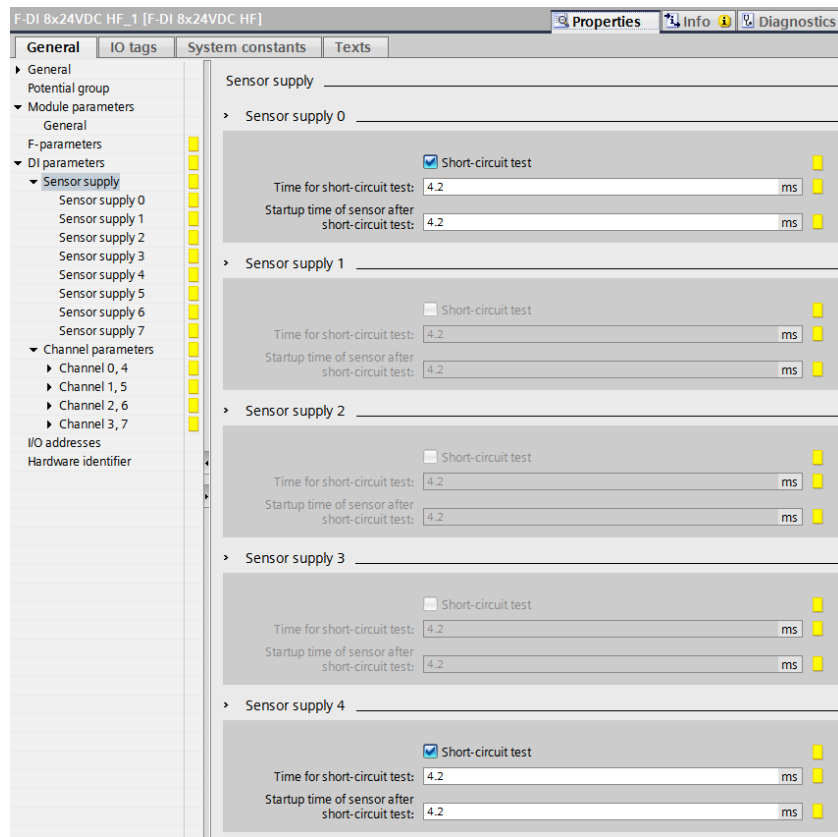

Activate the fail-safe output on channel 0.

Figure 4-5 F-DQ settings

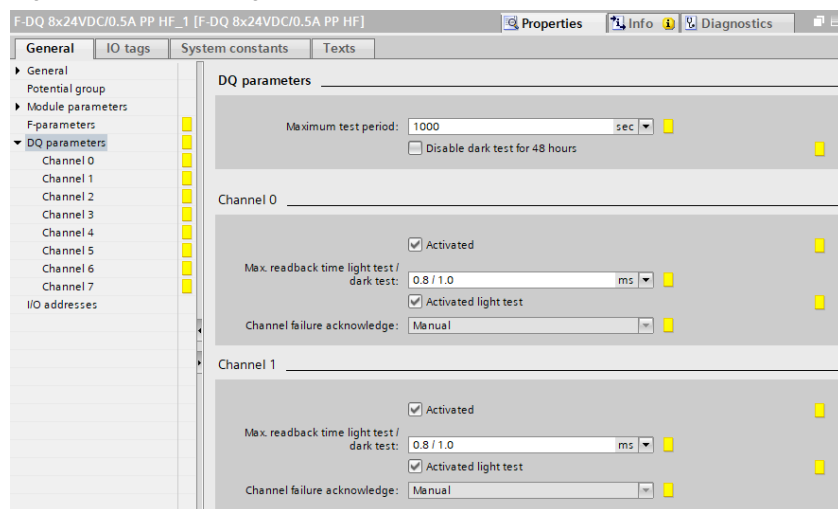

F-motor starter settings

For fail-safe operation of the motor starter, no other parameters need to be set in the motor starter's properties.

For correct operation of the motor, set the specific requirements of your application in the properties (e.g., rated normal current, current limits and shutdown class).

4.3 First commissioning

For safety mode of the F-DI and F-DQ modules, it is required to assign an F-destination address on the module.

For more information about assigning the F-destination address, please refer to the “SIMATIC Industrial Software SIMATIC Safety – Configuring and Programming” programming and operating manual:

<http://support.automation.siemens.com/WW/view/en/54110126>

First commissioning of the ET 200SP motor starter requires that safety-related parameters be acknowledged. Confirm the relevant parameters by pressing the reset button twice.

For more information about commissioning the fail-safe motor starter, please refer to the “SIMATIC ET 200SP Motor Starter” equipment manual:

<https://support.industry.siemens.com/cs/ww/en/view/109479973>

5 Mode of Operation

5.1 Complete overview

The following figure shows the standard user program and the safety program. It additionally shows the data exchange between the standard program and the safety program with a global data block.

Figure 5-1 Program overview

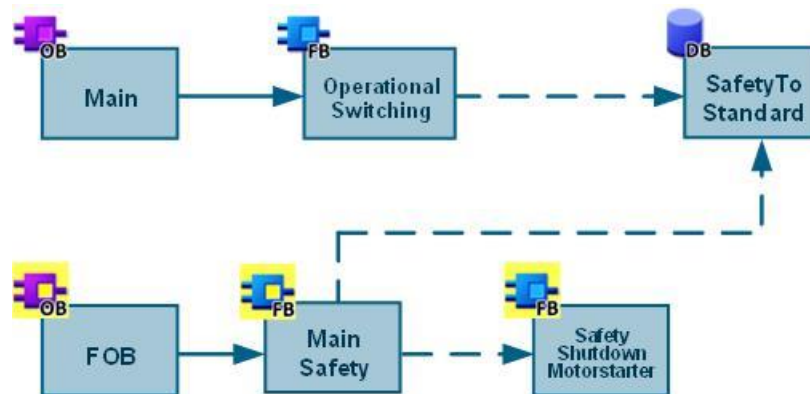

Table 5-1

Block	Function
OperationalSwitching	The standard user program is processed in this block.
MainSafety	This block contains the safety program and calls other safety-related instructions.
SafetyShutdownMotorstarter	Safety-related shutdown of the motor starter by triggering the emergency stop safety function is implemented in this block.
SafetyToStandard	In this global data block, the "OperationalSwitching" block provides the control signals to the safety program.

5.2 Safety program

An emergency stop safety function is evaluated in the application example shown in this document. When the emergency stop command device is actuated, the F-motor starters are shut down in a safety-related manner. In the safety program, the safety function is monitored using the ESTOP1 program block.

Program description

The ESTOP1 instruction is included in STEP 7 Safety Advanced. This program block is called in the "SafetyShutDown" FB.

If the emergency stop is not actuated, the ESTOP block outputs the value 1 at the Q output. This means that the motors can be functionally switched. Once the emergency stop has been actuated, the actuators immediately shut down in a safety-related manner. Then the emergency stop command device must be unlocked and acknowledged via the ACK input. An acknowledgment request is

output via the ACK_REQ output. The Q output is buffered to a static tag to simplify access to it in the next networks.

Figure 5-2 Network1

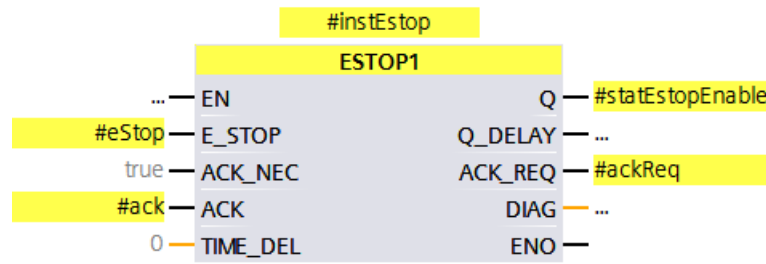
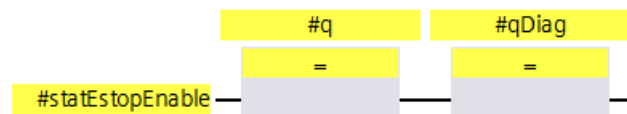
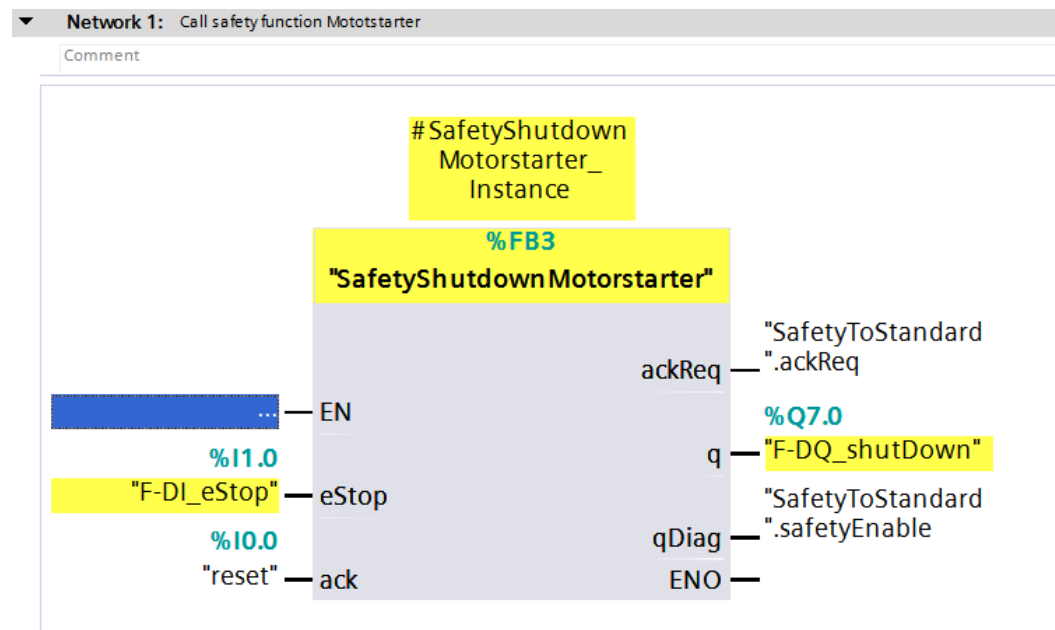

Figure 5-3 Network2



Once the “Main_Safety” FB has been called, the program block is interconnected.

Figure 5-4 Call of the Motorstarter F-FB



Via the “SafetyToStandard” interface, control signals are transferred from the safety program to the user program.

5.3 Operational switching of the motor starter

Operational switching of the motor starter is implemented in the standard user program. If the start conditions are met in the safety program, group shutdown of the motor starters can be started via the “commandOn” signal. The motor starters are operationally switched off via the “commandOff” signal. In addition, the reversing starter’s direction of rotation can be selected using “commandRight” and “commandLeft”.

Program description

The operational signals of the motor starter are controlled in the standard user program.

- Network 1 defines the conditions for switching on and off and buffers the result to a static tag for further processing.

During fail-safe shutdown using the emergency stop command device, no automatic restart must be performed; therefore, the inverse #SafetyEnable signal is included as a reset condition. If no safety enable has been given by the ESTOP1 block, the plant cannot be switched on.

Figure 5-5 Network 1

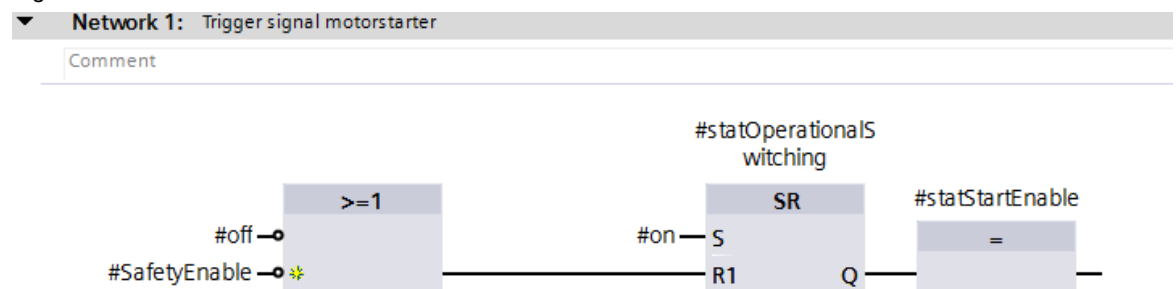

- Network 2 controls the direct-on-line starter’s output.

Figure 5-6 Network 2

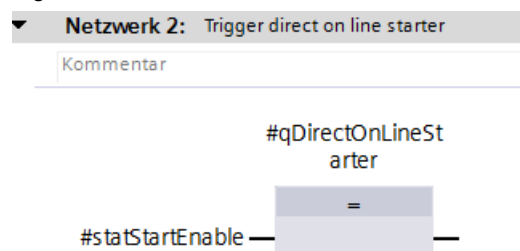

- Network 3 controls the reversing starter's direction of rotation right.

Figure 5-7 Network 3

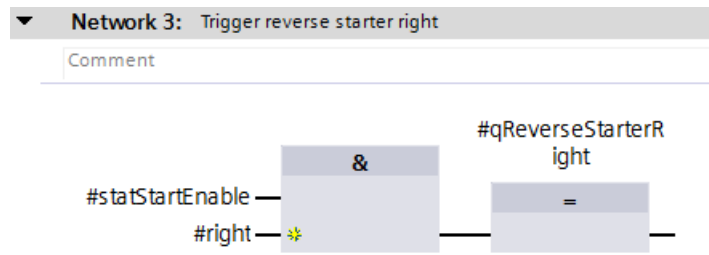

- Network 4 controls the reversing starter's direction of rotation left.

Figure 5-8 Network 4

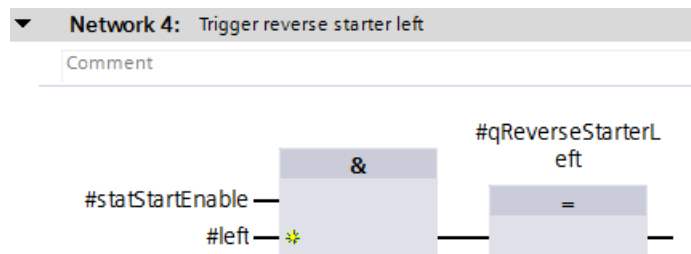

The standard program is configured by the call in the "Main" OB 1.

Figure 5-9 Call of the standard program

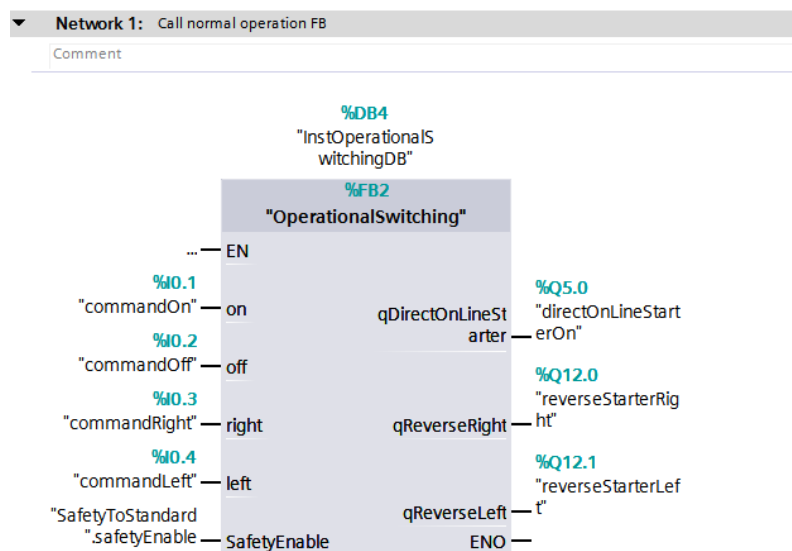

6 Diagnostics

Due to the fail-safe shutdown by the F-DI on the F-motor starter, you can evaluate and display all the signals of the F-motor starter.

The evaluation of a fail-safe shutdown operation can be evaluated by interconnecting control signals (e.g., emergency stop signal on the F-DI and F-DI on the F-motor starter).

The diagnostics concept has to be modified to the custom application and is therefore not included in the user program.

7 Links & Literature

Table 7-1

	Topic
\1\	Siemens Industry Online Support https://support.industry.siemens.com
\2\	Download page of the entry https://support.industry.siemens.com/cs/ww/en/view/109748128
\3\	

8 History

Table 8-1

Version	Date	Modifications
V1.0	06/2017	First version
V1.1	09/2019	Update with new base units MS7/9 with bridged F-DI